

Description

MP 44 Use

The MP 44's REMOTE LEVEL port provides a means to control the level of the MASTER mix from a remote location. The range of control is 0 dB to -40 dB. Applications include "gain riding" DJs, setting a comfortable listening level from a remote location and reducing the maximum available gain.

DA 26 or DA 26S Use

A port for a wired Remote Level control is provided for each of the six Outputs. Using the optional VR1 Remote control provides an audio taper response from 0 dB to > -80 dB. *To control more than one Remote Port with a single Remote control, it is only necessary to connect the Vr pin of each additional port.*

Voltages

Turn the power to the unit *off* until all connections are made. It is important to ensure that the Remote Ports are not subjected to sustained voltages outside the range of 0 to 5 VDC or high levels of static. Inputs are protected, however, caution is the better part of... you know. It is a good idea to install the wiring, connect it to the Remote and then make the final connections at the Remote Port.

Do *not* short the Vr pin to ground. This pin is current limited; however, excess heat is generated in the 5 V supply if a short occurs. *Never subject the Vr pin to voltages above 5 V.*

Remote Mounting

The VR1 remote assembly mounts in a standard U.S. electrical box with a minimum depth of 2.25" (5.5 cm). Use the flat head #6 screws supplied with the kit to mount the remote assembly and silk-screened front panel to the electrical box.

Install the knob so that the line on the knob is properly aligned with the silk-screening on the front panel of the remote. Install any Decora plate of your choice. For a secured installation, you may wish to leave the knobs off and use a blank Decora plate to cover the remote after adjustment.

Euroblock Connections

Be sure to note the wire color of each input in order to facilitate correct wiring to the controlled unit. If the ground or shield wire is left shorter, it acts as a strain relief for the other wires. Connect each wire to the 3-pin connector by fully inserting it in the correct socket and tightening the screw. Make sure wires are free of nicks and that the cable jacket is stripped back sufficiently to allow it to lie in the electrical box with the remote assembly inserted.

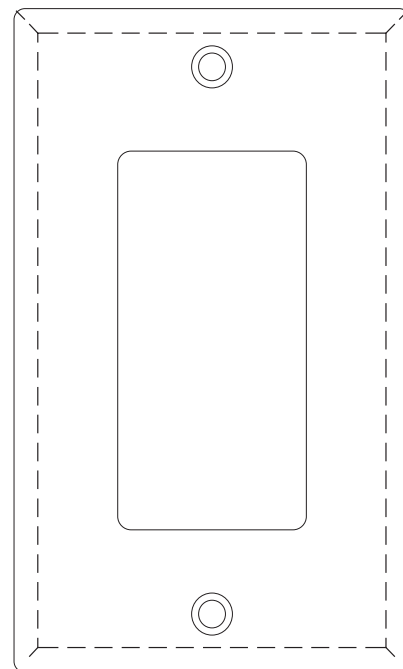
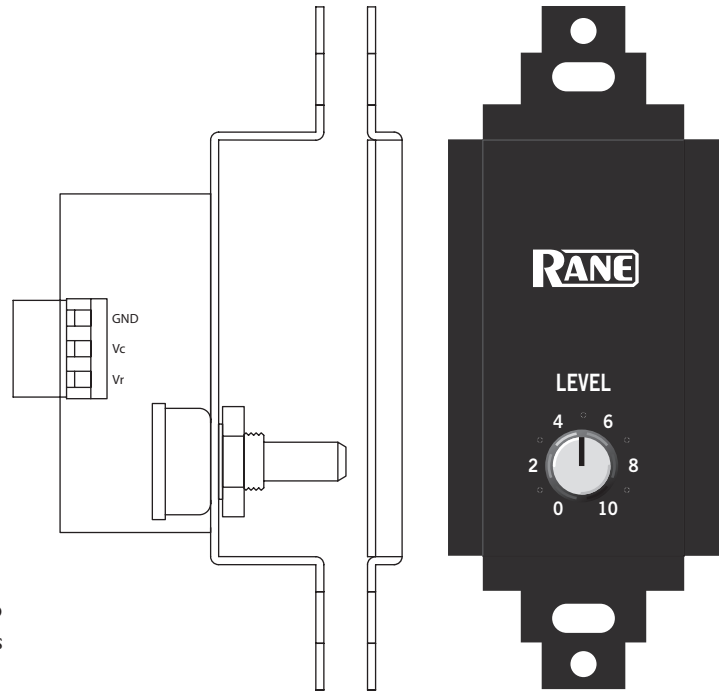

Decora plate cover, not supplied.

Wire Types

Variations in wire type do not greatly affect the performance of the remote controls. However, 22-gauge stranded wire with a flexible jacket is recommended. You may use 3-conductor unshielded remote control signal cable for shorter runs (less than 200 feet) or 2-conductor (1 pair) shielded remote control signal cable (use the shield as the GND return) for longer runs (200 to 1000 feet). The type of wire required is influenced by your installation and local electrical codes.

Rane Corporation does *not* provide or source cable. Please contact your local retail or wholesale outlet, *not* the factory. The following is a short list of suitable cable types:

CONSOLIDATED ELECTRONIC WIRE AND CABLE

Plenum cable:

Unshielded remote control signal cable CAT. # 9896

Shielded remote control signal cable CAT. #9877, CAT. #9852

WEICO WIRE & CABLE INC.

Communication and control cable:

Multiconductor, unshielded CAT. #7606

ALPHA

Communication and control cable:

Multiconductor, unshielded CAT. #1175C

BELDEN

Unshielded remote control signal cable CAT. # 88741

Shielded remote control signal cable CAT. # 88723

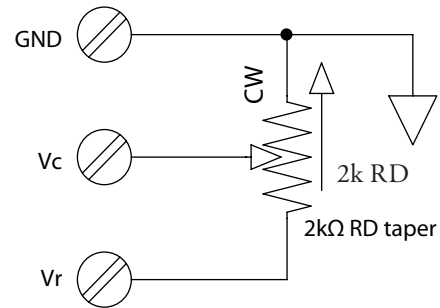

VR1 Block Diagram and Schematic

