

# AW Series On-Wall Loudspeaker Systems.

Perfect for  
under-eave  
applications  
like patios or  
balconies, and  
of course  
indoor BGM.

**O**ur AW series speakers are perfect indoor and outdoors—anywhere that a project calls for accurate music reproduction and intelligible voice

AW's deliver robust bass, crisp treble and accurate midrange that makes them easily heard over table conversation, traffic or wind noise. Their range of four sizes from micro to 8-inch, and sleek ovoid shape let them fit unobtrusively into any hospitality decor.

The two larger AW models are designed for either low-impedance or constant-voltage applications.

Impressive on their own, their sound can be further enhanced with Ashly power amplifiers and processors that incorporate Protēa or AquaControl™ software.



- Restaurant patios and interiors
- Bars and lounges
- Hotel lobbies
- Distributed audio in HoW, schools, sports/health clubs and public spaces
- Reception areas
- Warehouses



 **ASHLY.**



**DATA  
SHEET**  
on  
**PAGE THREE**

# AW Series

## Wall-Mount Loudspeakers



AW 2.1P



AW 3.2P



AW 5.2T



AW 8.2T

**A**W Series are made for both indoor and outdoor wall-mount applications. Dust and water-resistant, they're ideal for BGM use in bar/restaurants (including patios), paging and BGM for retail stores, distributed audio in HoW, schools, sports/health clubs and public spaces.

Highly efficient and durable, they complete the total Ashly solution when combined with Ashly's DSP and DSP-enabled amplifiers for the widest, most consistent coverage.

The AW Series is available in four model sizes: AW 2.1P 2.5" 8 Ω IP52 rated. AW 3.2P 3" 2-way 8 Ω, IP-52 rated. AW 5.2T 5" 2-way w/transformer, IP54 rated. AW 8.2T 8" 2-way w/transformer, IP54 rated. For extended LF response, add the SP-12.1P 12" Sub for full-range applications like DJ or Live Music Performance.

Two-way models incorporate Ashly's proprietary Directivity-Optimized Crossover (DOC). This gives AW Series speakers the widest, most consistent sweet spot.

AW Series can also benefit from improved linear frequency response when used with DSP presets available for Protea & AquaControl-enabled amps and processors.

■ **Wall-mounting hardware supplied; all models sold in pairs.**

	AW 2.1P	AW 3.2P	AW 5.2T	AW 8.2T
Speaker Type	Passive, Full-range	Passive, 2-Way	Passive, 2-Way	Passive, 2-Way
Frequency Response	170Hz~19KHz (-10dB)*	100Hz~19KHz (-10dB)*	80Hz~19KHz (-10dB)*	65Hz~19KHz (-10dB)*
Power Handling (RMS)	15W	45W @ 8 Ohms	80W @ 8Ω 70V (7.5W/5W/3.75W/2.5W) 100V (15W/10W/7.5W/5W)	100W @ 8 Ohms 70V (15W/10W/5W/2.5W) 100V (30W/20W/10W/5W)
Impedance	6Ω	8Ω	8Ω	8Ω
Sensitivity (2.83V/1m)	84 dB*	85 dB*	87 dB*	89 dB*
Max SPL	TBD	TBD	TBD	TBD
Crossover Type	N/A	Passive	Passive	Passive
Crossover Slope	N/A	HF - 12 dB/oct LF - 12 dB/oct	HF - 18 dB/oct LF - 12 dB/oct	HF - 12 dB/oct LF - 12 dB/oct
Crossover Point	N/A	2,600Hz	2,200Hz	3,200Hz
Beam Width	195° H x 205° V	155° H x 135° V	165° H x 160° V	115° H x 105° V
Directivity Index	6.2dB	6.4 dB	5.6dB	8.5 dB
Cabinet Material	ABS	ABS	Polypropylene	Polypropylene
Grille Material	ABS + Cloth	Steel (painted)	Steel (painted)	Steel (painted)
Environmental	IP52	IP52	IP54	IP54
Input Connection	Removable 2-pole Euroblock	Removable 2-pole Euroblock	Removable 4-Pole Euroblock	Removable 4-pole Euroblock
HF	N/A	1.1" PEI tweeter	0.75" silk dome tweeter	1" silk dome tweeter
LF	2.75" full-range	3.5", 1" voice coil 6.5 oz magnet	5.25", 1" voice coil 8 oz magnet	8", 1.25" voice coil 15 oz magnet
Dimensions (WxHxD)	3.22" x 3.82" x 4.13"	5.51" x 7.64" x 5.39"	7.32" x 10.23" x 7.04"	10.11" x 14.16" x 10.12"
Net weight	0.99 lbs	2.53 lbs	5.29 lbs	9.48 lbs
Supplied Accessories	Wall-mount bracket	Wall-mount Bracket Safety cable	Wall-mount Bracket Safety cable	Wall-mount Bracket Safety cable

\*With recommended Ashly Protêa or AquaControl™ DSP processing

- AW 5.2T and AW 8.2T have 70-100V Constant Voltage capabilities
- IP54 (AW 5.2T/8.2T)
- 5-Year Warranty
- Weather resistant (IP52 (AW 2.1P/3.2P) and

US toll-free +1.585.872.0010  
Fax +1.585.872.0739  
Sales@Ashly.com • [www.Ashly.com](http://www.Ashly.com)

 **ASHLY.**

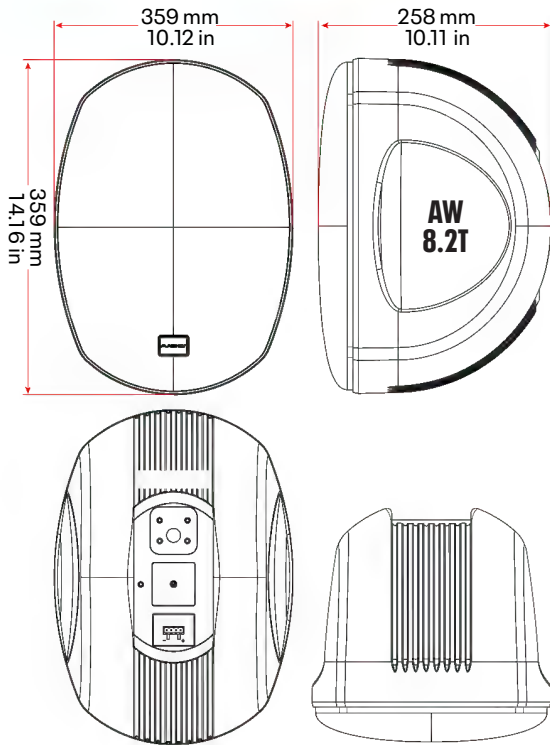

AW speakers will please you with their performance and price. But spec:

- nXp series multi-mode amps with Protêa
  - pêma series Protêa-enabled amps
  - ne4250pe and ne8250pe network-enabled amp with Protêa
  - ne series processors with Protêa
  - or mXa-1502 mix amp with AquaControl ... and you get:
  - Directivity-weighted, optimized linear frequency response
  - Universal crossover implementation for use with subwoofer and full-range speakers
  - FIR-corrected linear phase response above about ~300 Hz
- On the ne24.24m, only optimized linear frequency response and universal crossover functions are available.

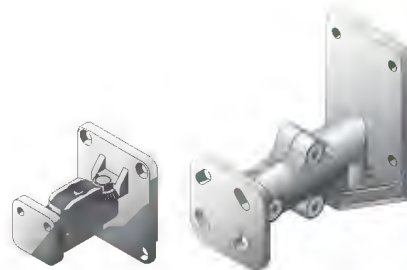
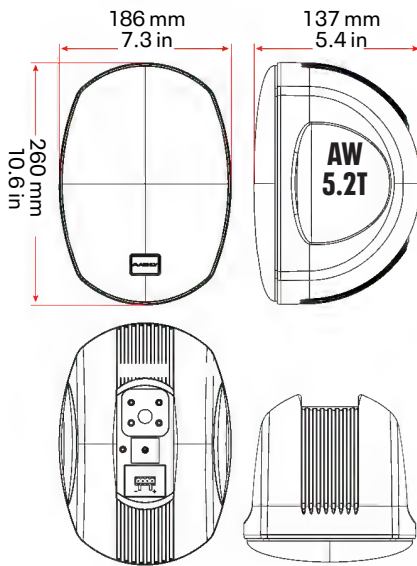

Tilt/Swivel Bracket for AW 2.1P & AW 3.2P

Tilt/Swivel Bracket for AW 5.2T & AW 8.2T

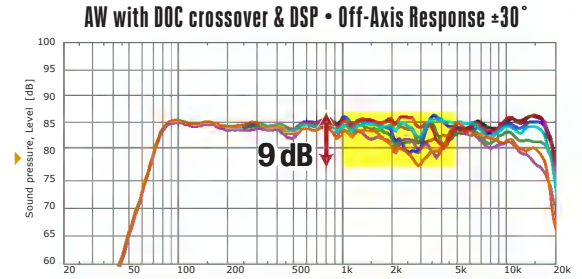
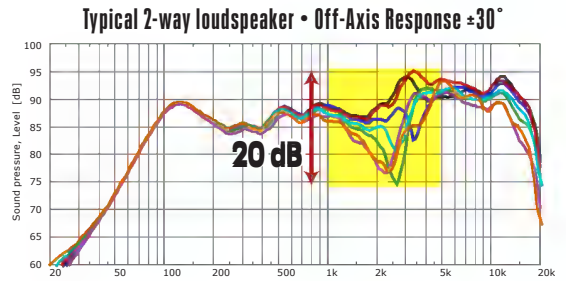
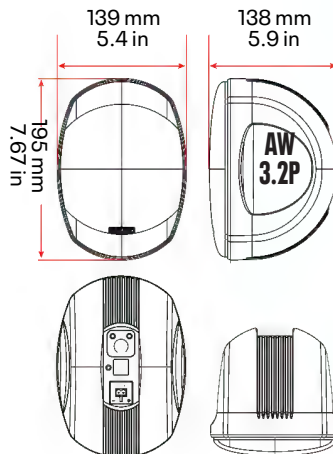
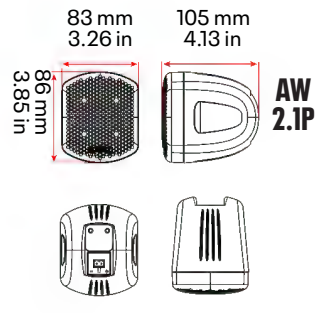

\*Directivity Optimized Crossover (DOC) passive crossover available on 2-way AW models only

**USER MANUAL**

SCAN ME

Or download the complete User Manual at [http://ashly.com/wp-content/uploads/2019/09/AW\\_Manual.pdf](http://ashly.com/wp-content/uploads/2019/09/AW_Manual.pdf)

**AW SERIES ARCHITECT & ENGINEERING SPECIFICATIONS**

in .txt and MS Word .docx format are available in the **DOWNLOADS** section of <http://ashly.com/sw series>

**AW SERIES 2D AUTOCAD FILES**

are available in the **DOWNLOADS** section of <http://ashly.com/aw series>

Ashly Audio, Inc. • 847 Holt Road • Webster, NY  
USA • US toll-free +1.585.872.0010  
Fax +1.585.872.0739 • Sales@Ashly.com

