



**Audio
Contractor**

VAIE 2000

Voice Alarm Integrated Systems

EN 54-16

0068-CPR-001/2014



VAR 2006 Router



VAC 2006 Controller

**MANUALE DI ISTRUZIONI
OPERATING MANUAL**

1. INTRODUCTION

1.1 SYSTEM OVERVIEW

The new **VAIE 2000** product range has been designed and manufactured in order to offer innovative solutions for making systems applied to emergency services. It is capable of managing alarm situations and of enabling guided and controlled evacuation, in accordance with the applicable standards (EN 54-16, ISO 7240-19 and EN 60849).

The architecture of the whole system is based on the **VAC 2006 controller**, management and diagnostics unit, which is particularly suitable for both large and small installations in which high levels of safety, flexibility and user-friendliness are required. The simplicity of the connections (using Cat. 5e SF/ATP shielded cable) between the various different management units, amplifiers and emergency microphone stations makes sound-broadcasting in complex buildings effective and inexpensive, enabling the use of both centralised and/or local equipment.

Each **VAC 2006 controller** has provisions for managing 6 control lines to which the following units can be connected directly:

- Digital power amplifiers equipped with diagnostics cards (**DPU range**), up to a maximum of 16 per line;
- **VAR 2006** router (1 for each line), capable of managing 6 zones with a double 100-V output line (A and B);
- Compact integrated 6-zone systems (**VAIE 2250**, maximum 1 for each line);
- Maximum number of zones in the whole system: **216**.

It is possible to connect up to a maximum of 6 VAC 2006 controllers with one another.

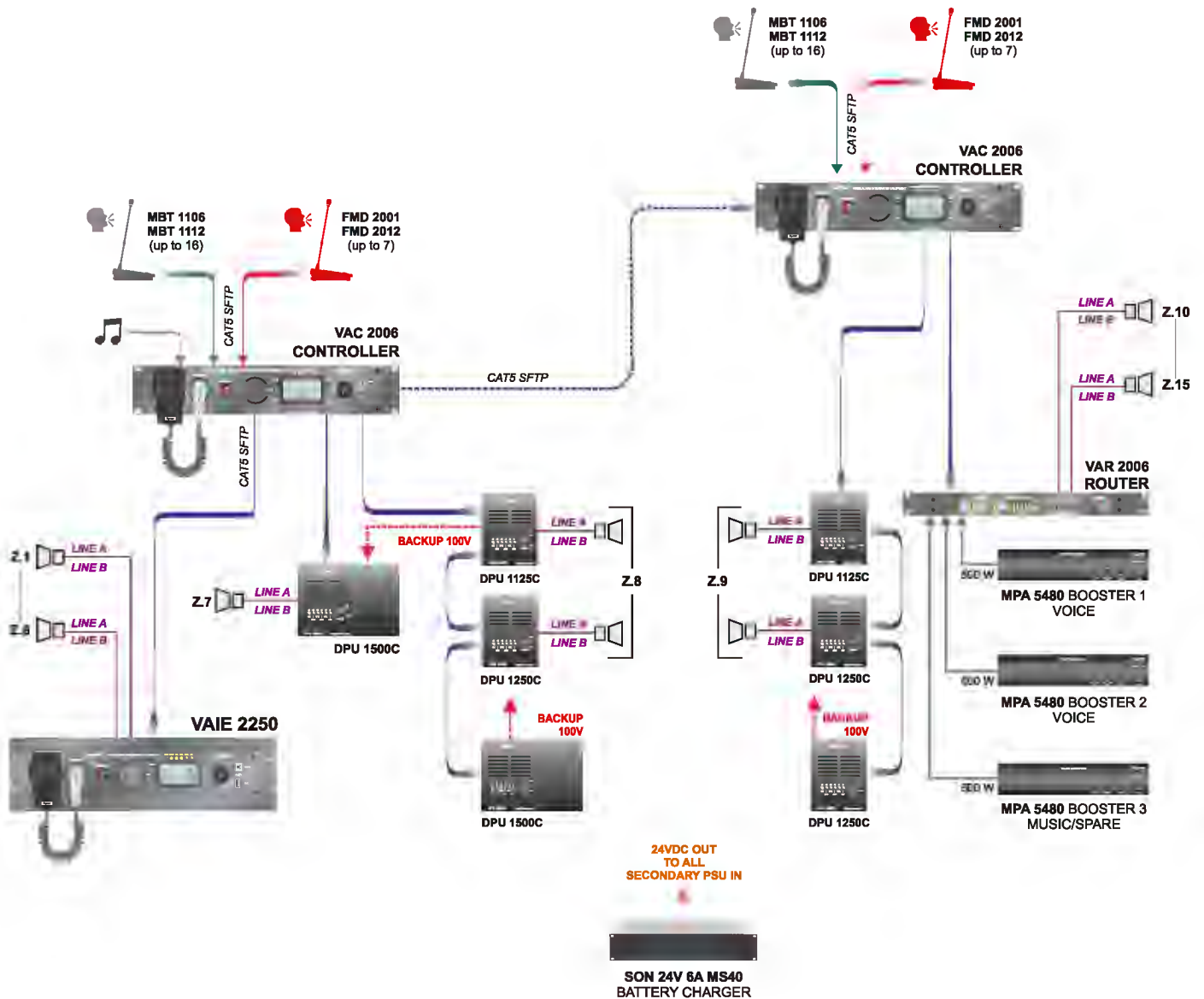

VAC 2006 controllers and digital amplifiers of the DPU range

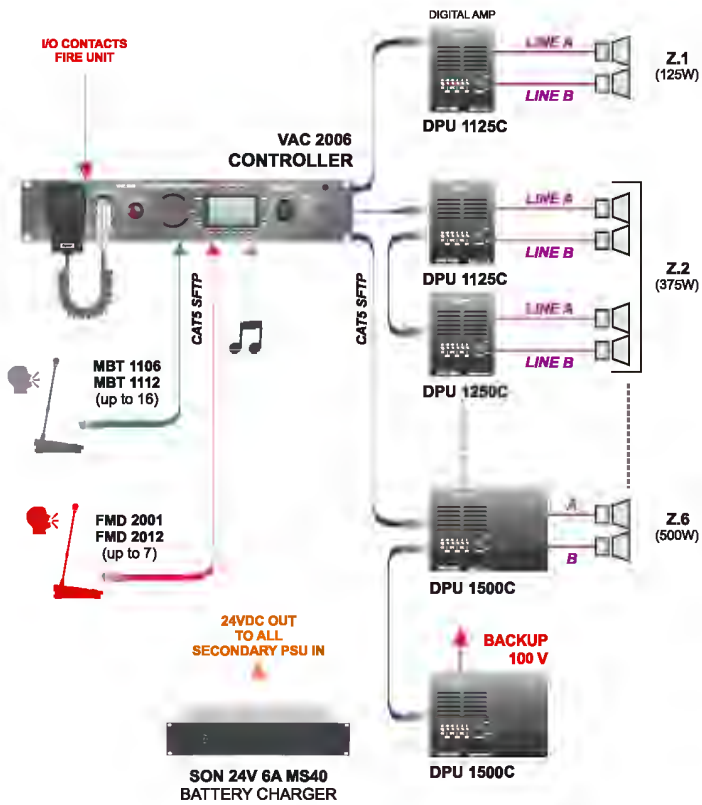

VAC 2006 controller and VAR 2006 router

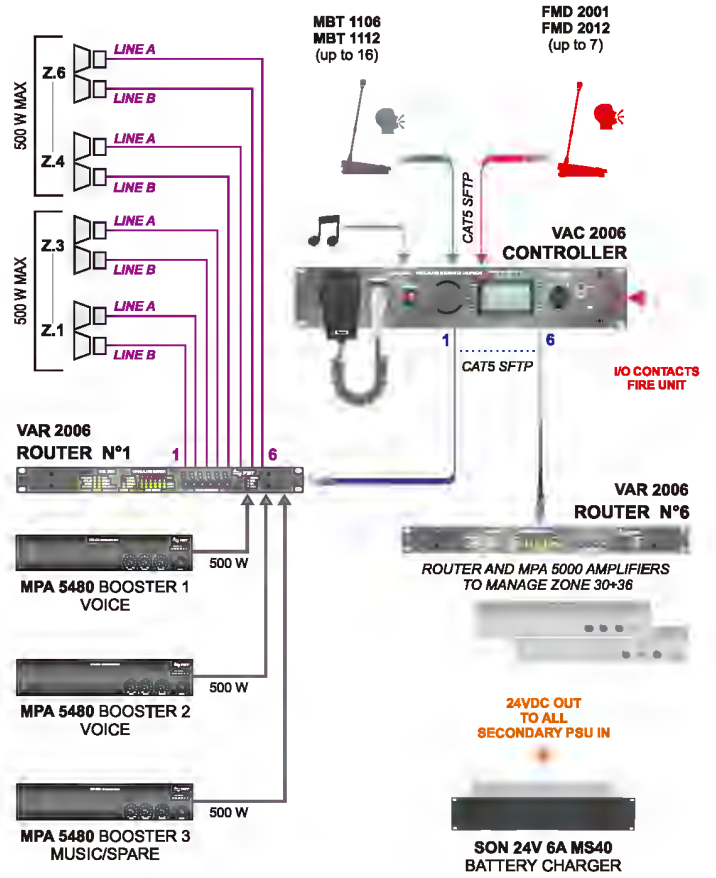

VAIE 2000 | System featuring a mixed configuration

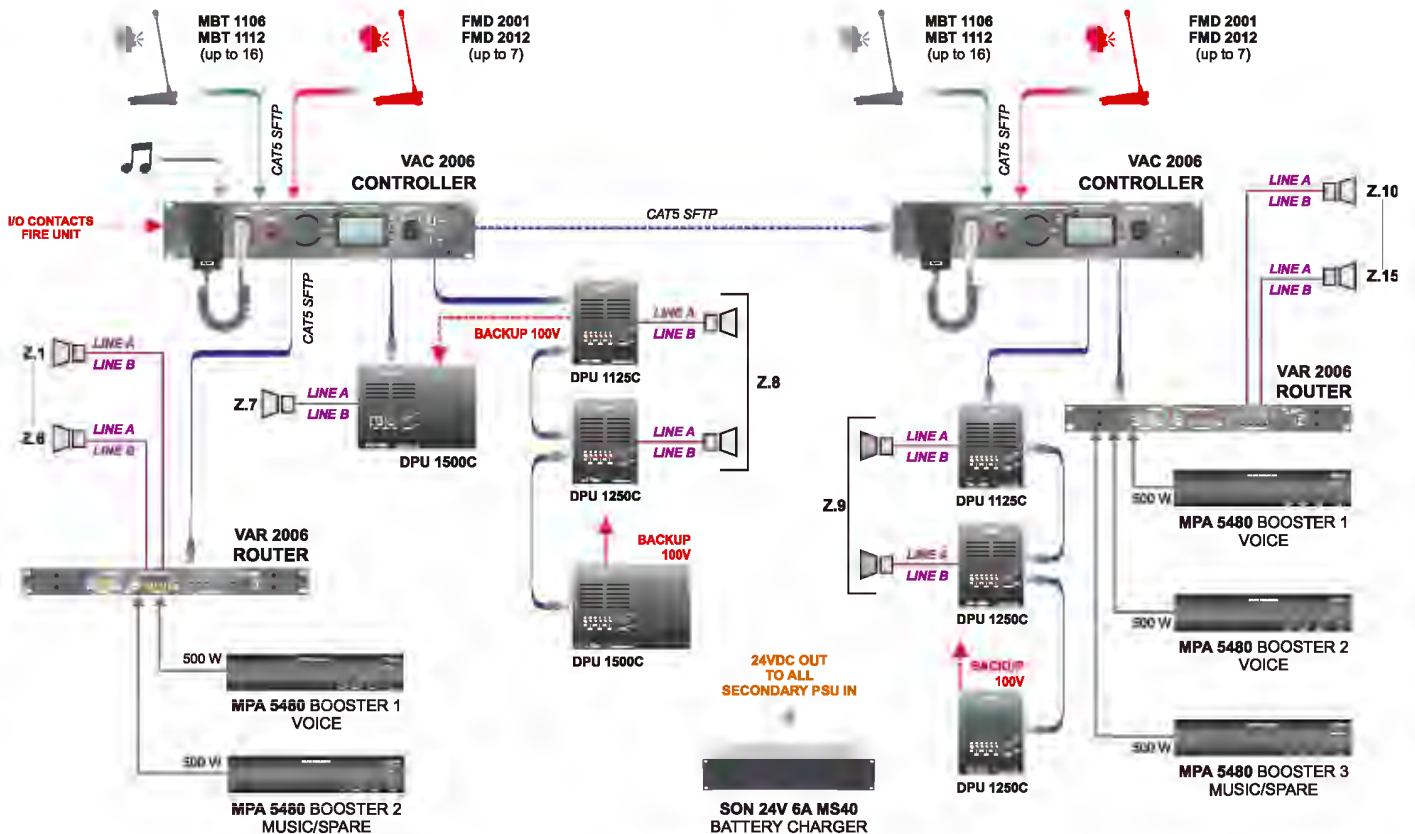

2. GENERAL DESCRIPTION

2.1 VAC 2006 CONTROLLER

- F1. Flush-mounted push-button for activating the Manual Emergency mode (EMERGENCY).
- F2. Hand-held microphone with a Push-to-Talk (PTT) key for live emergency announcements.
- F3. Backlit black-and-white graphic display, 128 x 64 pixels.
- R1. ON/OFF switch.
- R2. Inputs for connecting remote emergency microphone stations (**FMD 2012**, **FMD 2001**).
- R3. Sockets for connections between **VAC 2006** controllers (up to 6 units).
- R4. Input for connecting broadcast paging units (**MBT 1106**, **MBT 1112**).
- R5. Balanced input for a microphone or outside source / Terminal block for connecting a precedence contact.
- R6. Input for external microphone.
- R7. Input for connecting an external source of music.
- R8. 7 monitored digital inputs for control via external peripheral units.
- R9. 6 output lines for connection to amplifiers of the DPU range and/or VAIE 2250 compact systems and/or VAR 2006 routers.
- R10. Socket for connecting a Local Area Network with TCP/IP protocol for an Ethernet 10/100 network.
- R11. 3 relay outputs for signalling towards external peripheral units.
- R12. Terminals for 24 VDC external power supply.
- R13. Frame earthing connection.
- R14. Plug for 230 VAC mains power supply, with built-in fuse.

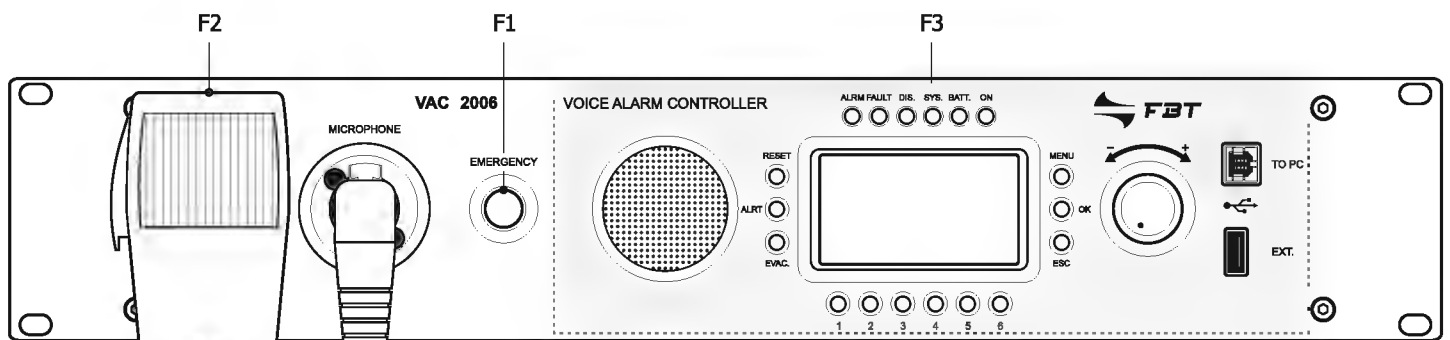

See details on page 76.

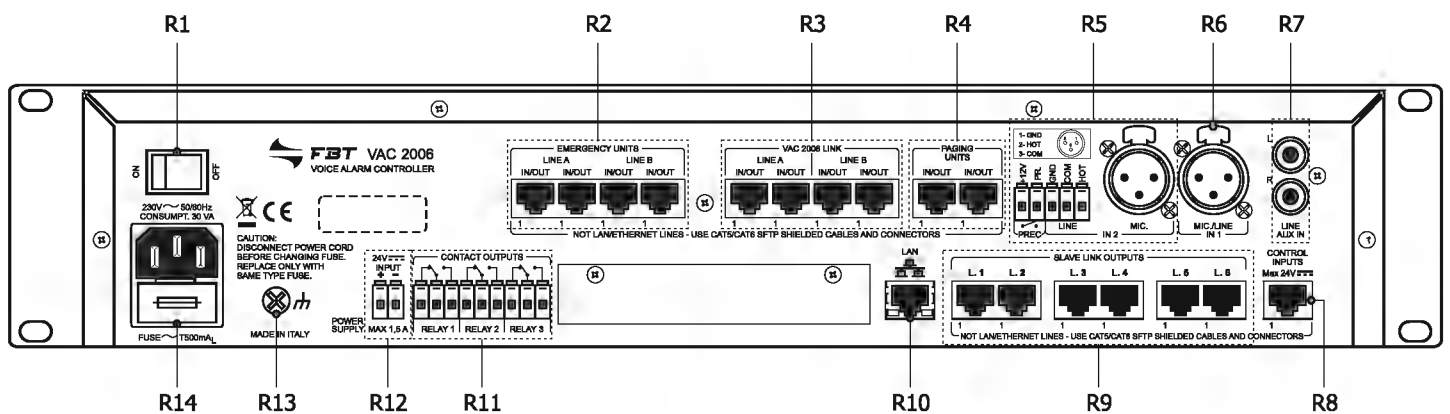

2.1.1 Main features of the controller

- Monitored front-panel emergency microphone.
- Two-channel sound-broadcasting system.
- Message generator for broadcasting two-channel voice alarms (EVAC and ALERT).
- USB input as a source of background music.
- Automatic management of the stand-by amplifier.
- Input for 24 VDC secondary power supply.
- 7 programmable and controlled input contacts.
- 3 relay outputs.
- 6 control lines for digital amplifiers of the **DPU** range and/or **VAR 2006** routers and/or **VAIE 2250** integrated evacuation systems.
- 4 redundant lines for connections among the various different controllers (max 6).
- 2 redundant lines for emergency microphone bases of the **FMD** range (max 7, with 7 priority levels).
- 2 redundant lines for call stations of the **MBT** range (max 16, with 7 priority levels).
- B/W graphic display, 128x64 pixels, for easy configuration and rapid use of monitoring screen pages.
- Diagnostics and failure signalling.
- Can be mounted in a standard 19" rack (height: 2 units).

2.2 VAR 2006 ROUTER

- F4. Failure-signalling LED.
- F5. Router/system status LED.
- F6. Output zone status LED.
- F7. Zone-selection buttons for BGM.
- F8. Power supply/call status LED.
- R1. ON/OFF switch.
- R11. 2 relay outputs for signalling towards external peripheral units.
- R12. Terminal block for 24 VDC outside power supply.
- R13. Frame earth connection.
- R14. Plug for 230 VAC mains power supply with built-in fuse.
- R15. Terminal block for connection to amplifier outputs.
- R16. Loudspeaker output terminal blocks
- R17. Programmable inputs/outputs.
- R18. Voice amplifier output - *Music/standby* amplifier output.
- R19. Input/output for connection to a VAC 2006 controller.

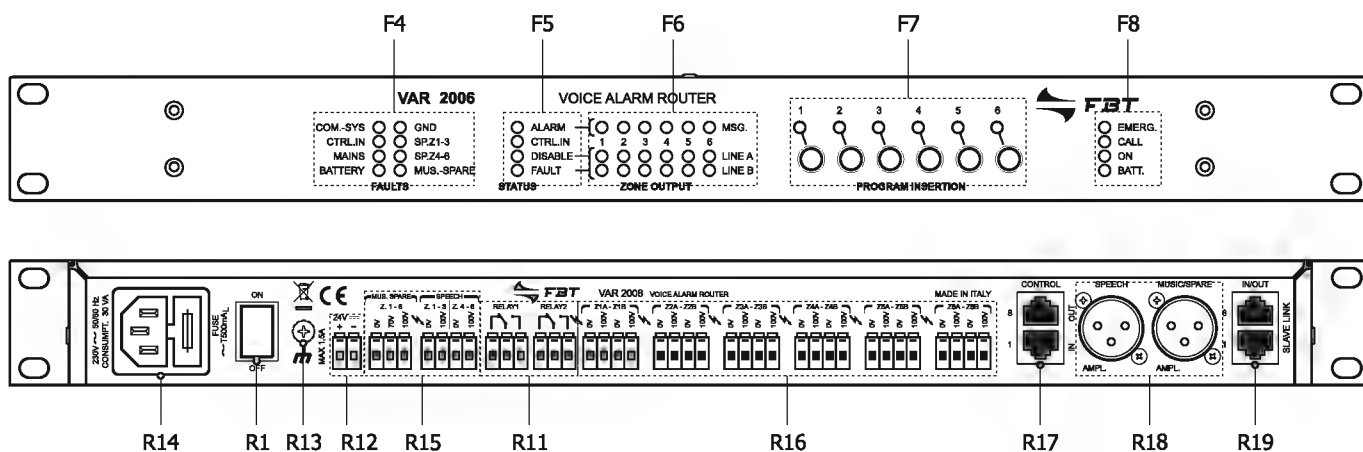

2.2.1 Main features of the router

- 6 two-line (A and B) loudspeaker zone outputs.
- 100-V double input for 1 or 2 voice amplifiers (IN 1: zones 1 to 3, IN 2: zones 4 to 6).
- 100-V input for music/standby amplifier.
- Music can be activated/de-activated separately for each zone by means of the front-panel push-buttons provided for this purpose.
- RJ45 sockets for connection to the **VAC 2006** controller.
- 7 programmable and controlled input contacts.
- 6 open-collector outputs.
- 2 relay outputs.
- Can be mounted in a standard 19" rack (height: 1 unit).

3. WARNINGS

3.1 POWER SUPPLY AND EARTHING

This equipment is designed to run on a mains voltage of 230 V \pm 10% 50/60 Hz. The ON/OFF switch (**R1**) switches the mains voltage on and off. The equipment is supplied with a power cable that has an earth wire. The earth terminal of the mains plug must not be removed under any circumstances. Connect the mains plug (**R14**) of the device to the power mains using only the cable supplied with the equipment, which is equipped with a noise-suppressor. Make sure that the power outlet has an earth connection in accordance with the law. The power circuit of the **VAC 2006** is protected by a fuse on the mains plug of the device.

3.2 SAFETY NOTES

Any activities inside the equipment, such as maintenance operations and so on, must be carried out solely by specialised personnel. When the cover is removed, parts become accessible that entail a risk of electric shocks. Always make sure that the power cable is unplugged from the outlet before removing the cover. If any liquid is accidentally spilt onto the equipment, unplug it immediately from the mains and contact the nearest **FBT** Service Centre. In case of rack installation, it is required to connect the (**R13**) connection to the to rack frame by means of a cable as short as possible (about 20cm). It's also possible to connect other equipments for the sole purpose of shielding low-level signals. This socket must not be used for the safety connection of the frame to earth.

3.3 INSTALLATION

All **FBT** equipment is made according to the strictest international safety standards and complies with European Community requirements. For correct and effective use of the equipment, it is important to be aware of all its characteristics by reading carefully these instructions and especially the safety notes. It is necessary to ensure adequate ventilation while the equipment is in use, and to leave the side ventilation slit for the cooling fans unobstructed. Do not position the equipment inside a cabinet without ventilation and keep it away from sources of heat. The equipment can be mounted in **FBT** standard 19" racks.



Important information for correct disposal of the product in accordance with EC Directive 2002/96/EC

This product must not be disposed of as urban waste at the end of its working life. It must be taken to a special waste collection centre licensed by the local authorities or to a dealer providing this service. Separate disposal of electric and/or electronic equipment (WEEE) will avoid possible negative consequences for the environment and for health resulting from inappropriate disposal, and will enable the constituent materials to be recovered, with significant savings in energy and resources. As a reminder of the need to dispose of this equipment separately, the product is marked with a crossed-out wheeled dustbin.



This product is in keeping with the relevant European Community Directives.

4. CONNECTIONS

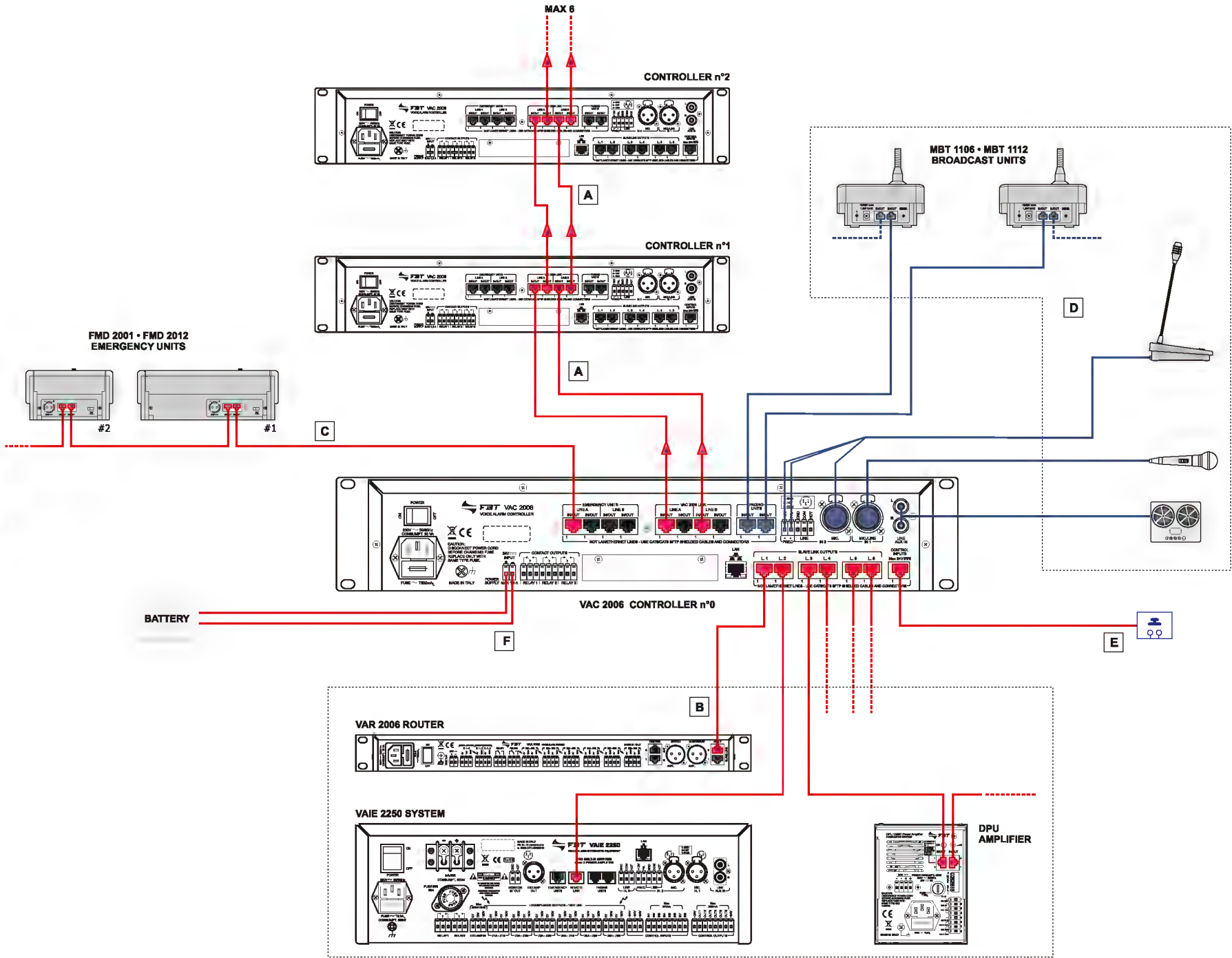

A) CONNECTION AMONG CONTROLLERS

Use Cat.5e SF/UTP cables in the 'VAC 2006 LINK' sockets (R3) to connect the controllers of the system (max 6) with one another.

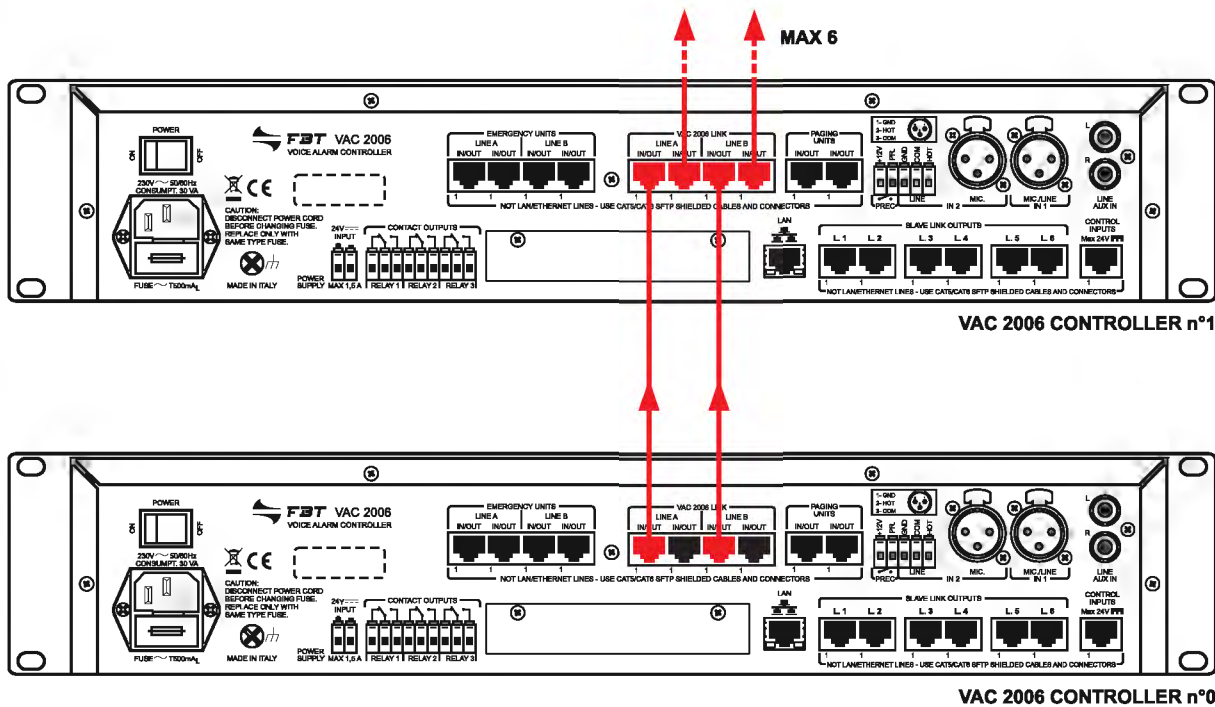

B) CONNECTING THE OUTPUT LINES

Use the 'SLAVE LINK OUTPUTS' sockets (R9) to connect the following to the controller:

- B1) VAR 2006 router.
- B2) VAIE 2250 compact emergency system.
- B3) Amplifiers of the DPU range.

B1) VAR 2006 router

Use Cat.5e SF/UTP cables to connect the 'SLAVE LINK OUTPUTS' sockets (R9) to the 'IN/OUT SLAVE LINK' sockets on the router.

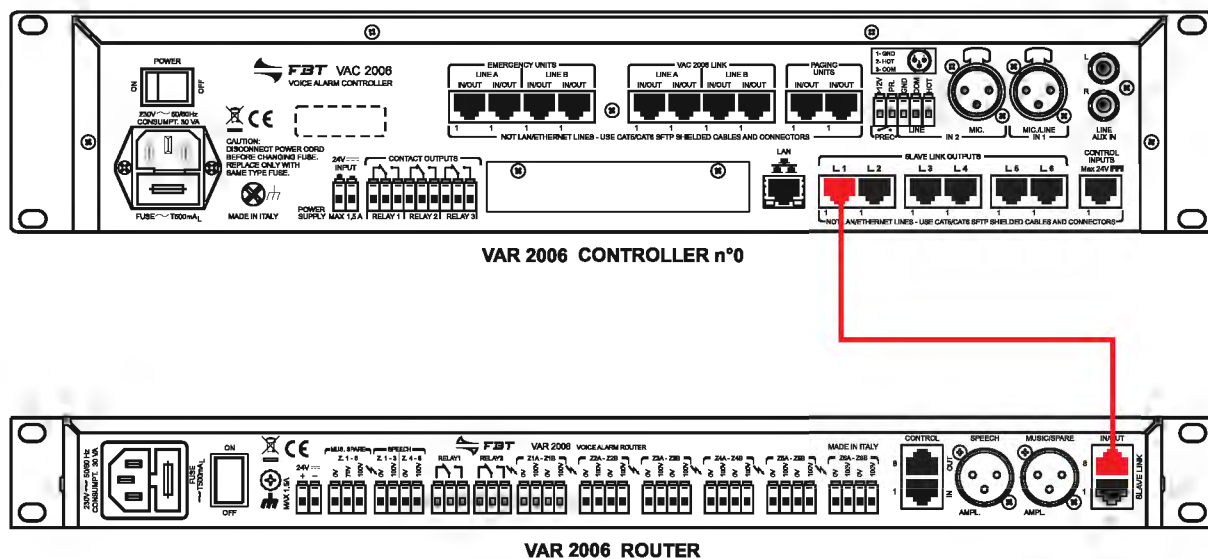

B2) VAIE 2250 compact emergency system

Use a Cat.5e SF/UTP cable to connect one of the 'SLAVE LINK OUTPUTS' sockets (R9) to the 'REMOTE LINK' socket on the VAIE 2250 compact system.

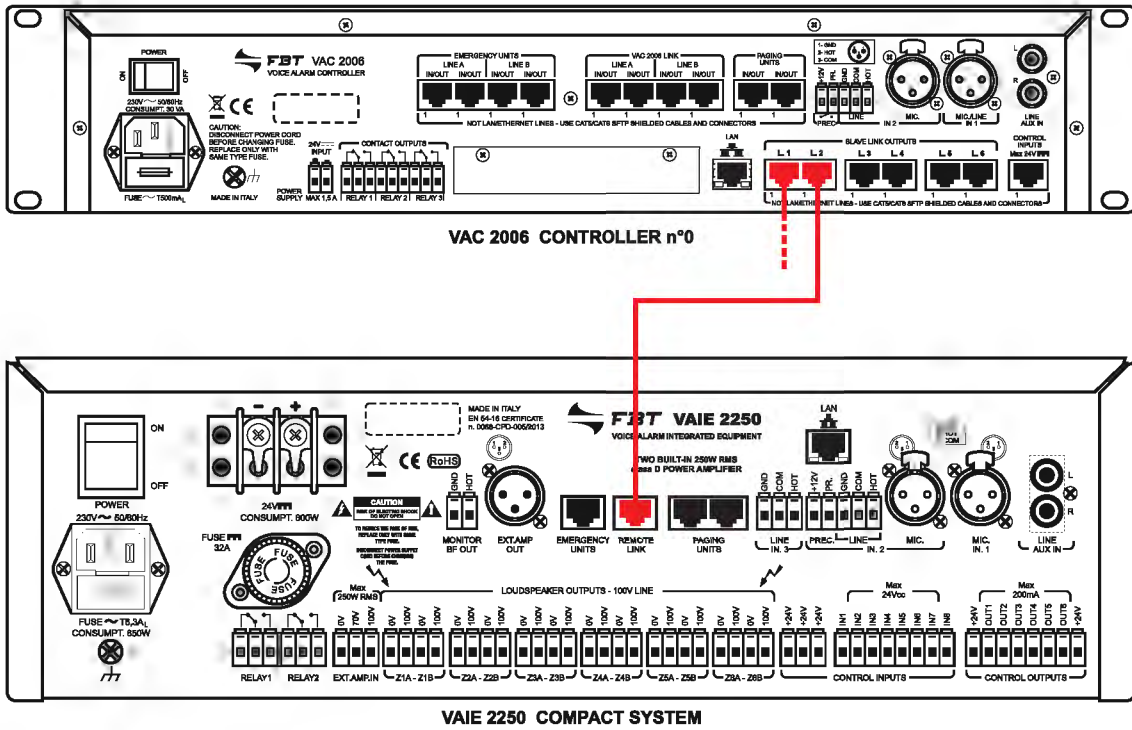

B3) Amplifiers of the DPU range

Use a Cat.5e SF/UTP cable to connect one of the 'SLAVE LINK OUTPUTS' sockets (R9) to the 'IN/OUT' socket on the amplifier (DPU 1125C, DPU 1250C or DPU 1500C).

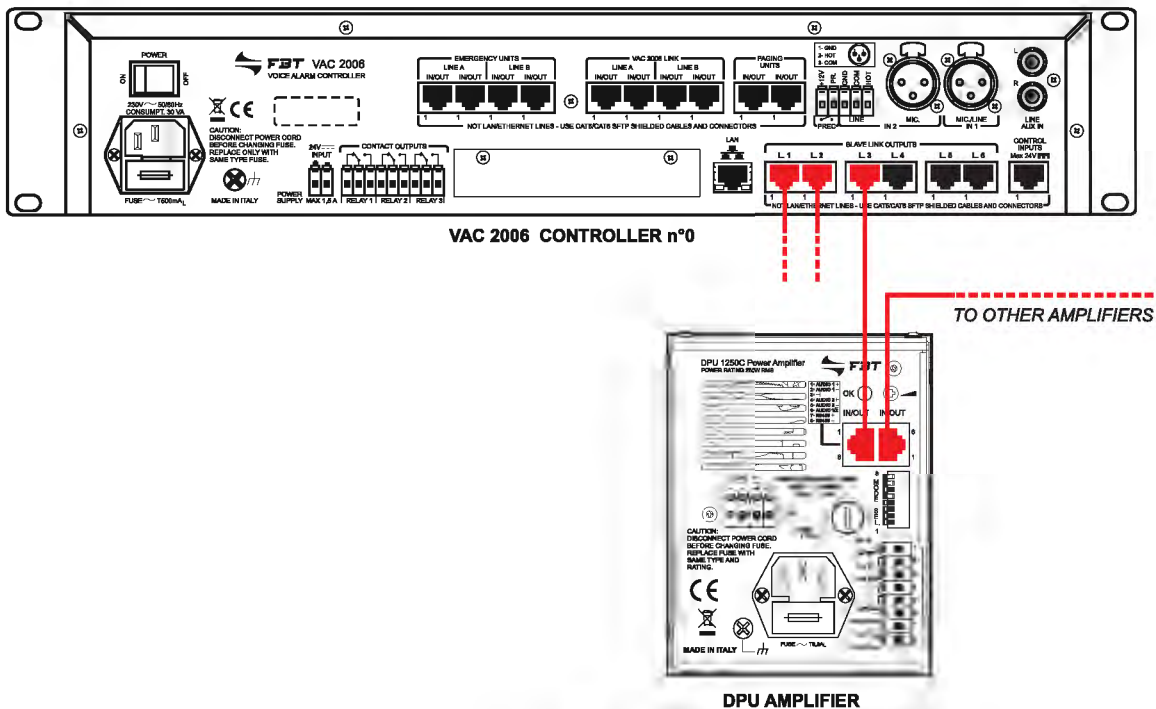

C) CONNECTING THE EMERGENCY STATIONS

Use CAT. 5e SF/UTP cables to connect the 'EMERGENCY UNITS' sockets (R2) on the controller to the 'IN/OUT' sockets of the FMD 2001 and/or FMD 2012 stations.

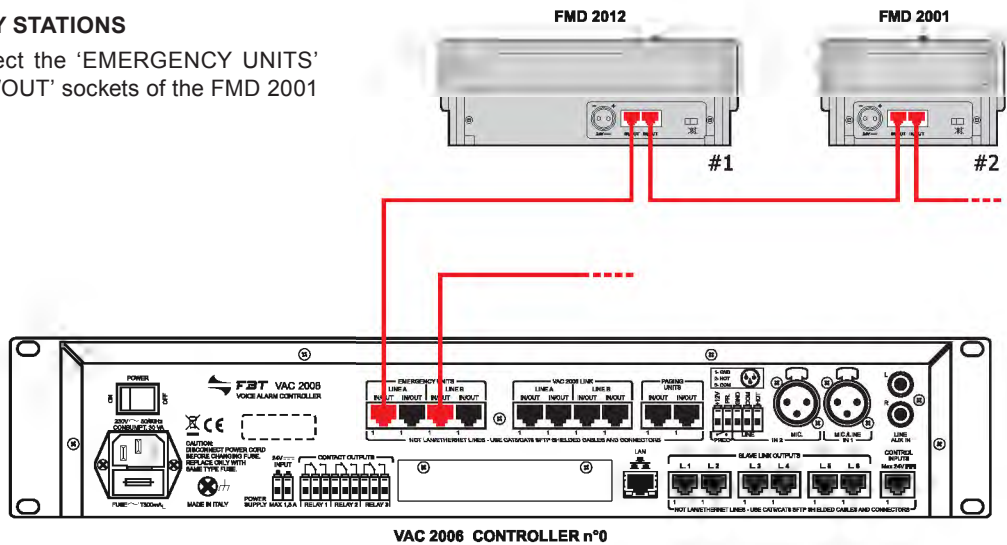

D) CONNECTING THE AUDIO INPUTS

D1) Sources of BGM, "music" amplification channel

Connection of an example of sound sources at line or microphone level, balanced or unbalanced, selectable from the MUSIC panel and addressable to the required zones by means of the zone activation keys. For details concerning the settings, refer to the relevant sections indicated in the MUSIC and AUDIO SETTING menus.

A - Source of music with unbalanced output at the level of the line connected to the AUX IN input.

To receive, select the "AUX" BGM source from the MUSIC menu.

B - Receiver of the radio microphone kit with output balanced at the level of the microphone connected to the IN.1 input.

To receive, select the "INPUT 1" BGM source from the MUSIC menu.

Set the following, via the INPUT 1 panel: > MODE: OFF

> PH: OFF

> The Chime, Priority and Zone list parameters have no effect.

C - Mixer with output balanced at the level of the Line connected to the IN.2 LINE input.

To receive, select the "INPUT 2" BGM source from the MUSIC menu.

Set the following, via the INPUT 2 panel: > MODE: OFF

> PH: OFF

> The Chime, Priority and Zone List parameters have no effect.

Caution! Do not connect any other equipment to the MIC socket of the IN.2 input.

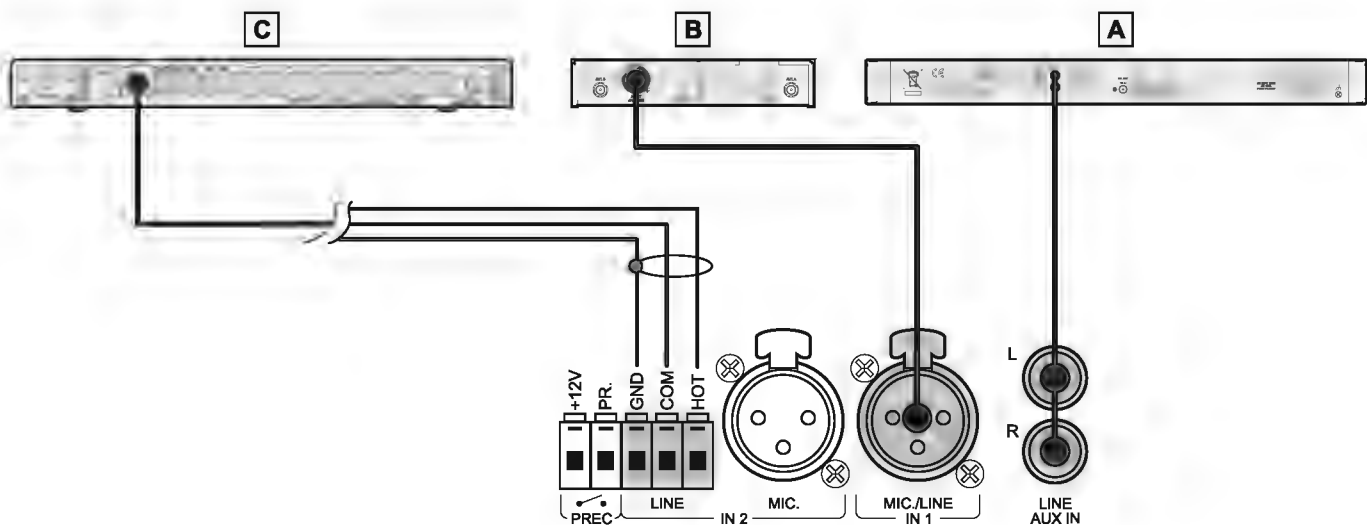

D2) Various types of PA source with progressive degrees of priority, “voice” amplification channel

Connection by way of example of one table-top microphone station, not pre-amplified, with a precedence contact; of one grip-type microphone with automatic VOX activation over music; of one PABX with an audio output for automatic announcements over the sound-broadcasting system and digital stations of the MBT range for service announcements with zone selection. For details concerning the settings refer to the relevant sections indicated under AUDIO SETTING.

A - Table-top base with electret microphone, balanced output connected to the IN.1 input – MIC and precedence contact connected to the PPREC. input.

The announcement will be addressed to the group of zones indicated in the ZONE LIST on the basis of the priority set.

Set the via the INPUT 1 panel:

- >MODE: PRECEDENCE
- >PH: ON
- >Priority: 3
- >Zone list: as desired
- >VOL.: as desired

Set the via the CHIME panel: > MIC 1: ON

B - Grip-type dynamic microphone, balanced output connected to the input IN.2– MIC with VOX function.

The announcement will be addressed to the group of zones indicated on the ZONE LIST according to the priority that is set.

Set the via the INPUT 2 panel:

- >MODE: VOX
- >PH: OFF
- >Priority: 1
- >Zone list: as desired
- >VOL.: as desired

Set the via the CHIME panel: > MIC 2: OFF

Caution! Do not connect any other equipment to the LINE terminals of the IN.2 input.

C - Digital microphone stations connected in cascade formation to the PAGING UNIT input. The announcement will be addressed to the zones indicated when programming the keys of the bases depending on the priority set for each base. Set the PAGING UNITS panel:

>VOL.: as desired (volume of the whole line for all the bases)

Set the CHIME panel: > UNIT: ON

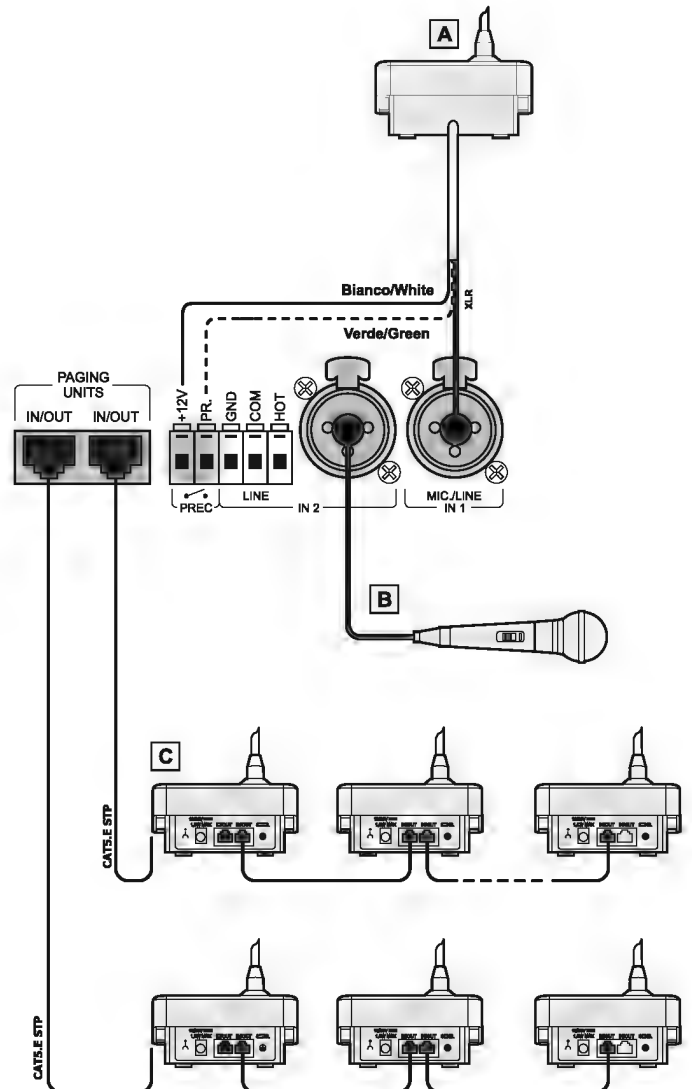

Sizing: For each VAR 2006 unit, up to a maximum of 16 stations of the PAGING UNITS range can be connected. Use the Cat. 5 SF/UTP connecting cable, with its shielding plait. The following limits must be observed for the connections:

N. 1 station connected to a line 800 metres long.

N. 8 stations distributed along 2 lines, each 200 metres long (4 stations per line).

For systems calling for greater distances or a higher number of stations to be connected, it is advisable to power the stations by means of the additional power supply unit connected to the local socket of the base. The maximum length of the connecting line, adding up the lines connected to the two RJ45 sockets, is 1 km. For further details concerning the type of power supply, the configuration of the cable, programming of the selection keys and setting of the priorities and addresses, refer to the Instruction Manual of the stations of the MBT range.

The following PAGING UNITS can be connected to the VAC 2006:

- **MBT 1106:** 6-zone paging unit.
- **MBT 1112:** 12-zone paging unit.

N.B.: The connections between the VAC 2006 and PAGING UNITS must be made solely with CAT. 5e SF/UTP.

E) RJ45 INPUT CONTACTS (CONTROL INPUTS)

There are 7 contacts on the CONTROL INPUTS (R8) socket. An example of a connection is shown in the figure.

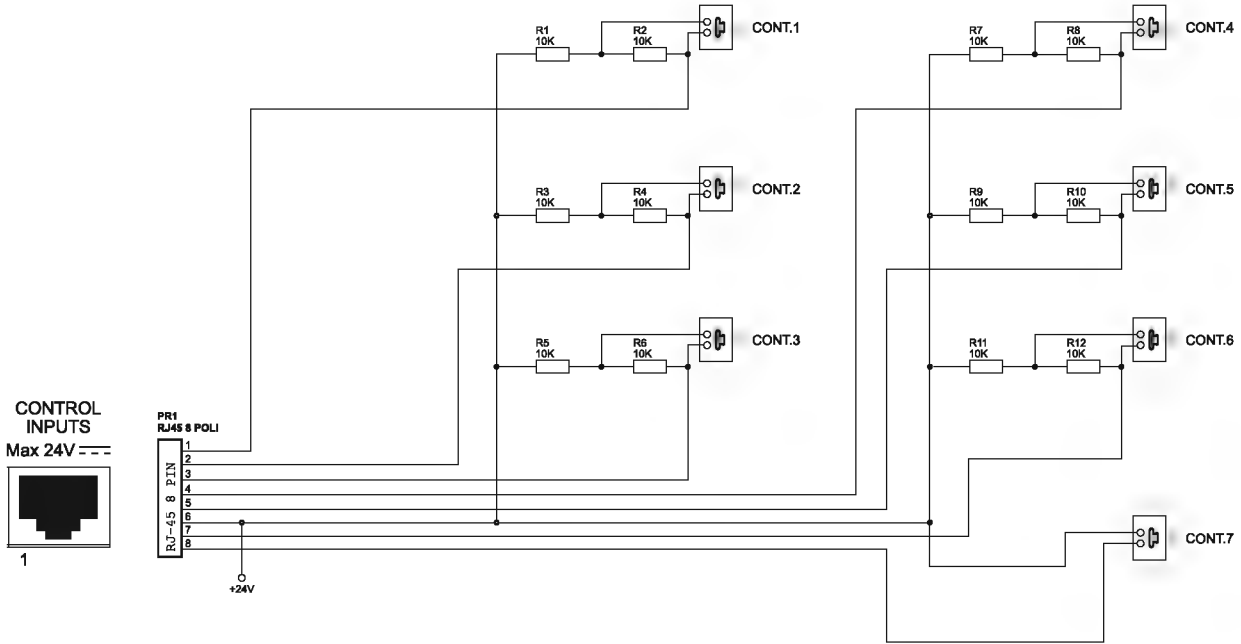

N.B.: In the example, contacts 1 to 6 are controlled while contact 7 is not.

F) CONNECTING AN EXTERNAL POWER SUPPLY

A connection for a 24 VDC outside power supply is available on the terminals provided (R12).

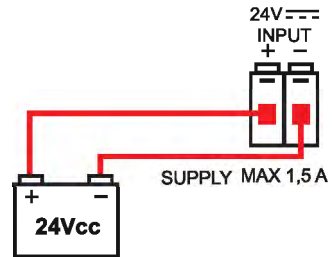

5. OPERATING CONDITIONS AND TERMINOLOGY

5.1 GENERAL DEFINITIONS

Following is a list of the signalling modes of the operating conditions of the system and of definitions used in the rest of the manual, completed by indications of a general nature:

5.1.1 Signalling of operating conditions

The VAC 2006 system is structured to signal the different operating conditions on the basis of the following definitions:

“Quiescent condition” (ALARM – FAULT – DIS – SYS LEDs extinguished)

Normal operating condition, with no current failures or emergencies. This status enables the sources of music and voice to be managed for service announcements.

“Alarm Condition” (ALARM LED illuminated)

This operating condition signals the current presence of at least one alarm signal, either pre-recorded or live, on at least one output zone. The “Alarm Condition” can be activated in the form of an Automatic Emergency from an external peripheral unit connected to the Control Inputs or of a Manual Emergency through an authorised operator. During an “Alarm Condition”, the functions of the music sources and of the voice services referred to the quiescent condition are not operational.

“Fault warning condition” (Led FAULT)

Operating condition signalling the presence of at least one on-going failure, detected by the internal diagnostics system causing the FAULT LED to light up steadily.

In the event of failure of a remote controller, the FAULT LED will flash.

It is accompanied by an acoustic signal (buzzer) indicating the failure. Depending on the causes of the failure, the system may in any case perform the functions relating to the “Quiescent” and “Alarm” conditions.

“System Fault” (SYS LED illuminated)

This operating condition signals that the system is blocked as the result of a temporary or permanent malfunctioning of the CPU, detected by the watchdog. It is accompanied by an acoustic signal (buzzer) indicating the failure. During a System Fault, the functions relating to the “Quiescent” and “Alarm” conditions are not operational.

“Disablement condition” (DIS LED illuminated)

This operating condition signals that the Alarm signals for at least one output zone have been set to a Disablement condition. The system can in any case carry on the functions pertaining to the “Quiescent” condition for all the zones and, only for those zones that are not disabled, the functions pertaining to the “Voice Alarm Condition”.

“Automatic Emergency” (CONTROL INPUT STATUS Display with zones active)

This indicates a sequence of operations performed from an external peripheral unit connected to the Control Inputs. Depending on how these inputs are programmed, the “Voice Alarm Condition” or an Alarm Reset are activated.

“Manual Emergency” (LED of the EMERGENCY button ON/flashing)

This procedure is performed by an authorised operator using the manual controls, to activate Emergency sources or to reset the Alarms (Manual Alarm Reset). The operations carried out in the Manual Emergency mode have a higher priority than those activated by an Automatic Emergency. A VAC 2006 unit or an emergency unit on which the EMERGENCY LED is **illuminated** is enabled for use for activating Emergency sources or for resetting the alarms. A VAC 2006 unit or an emergency unit on which the EMERGENCY LED is **flashing** indicates that a Manual Emergency has been activated from a remote station.

5.1.2 Glossary

Following is a list of definitions of terms used in this manual, completed by indications of a general nature.

“BGM Source”:

One of the following audio sources using the “Music” amplification channel (BackGround Music):

- Audio source connected to the AUX input.
- Flash memory device containing *.mp3 files plugged into to the front-panel USB EXT socket.
- Sorgente audio collegata all'ingresso IN 1 (Microfonico) con modalità impostata MODE: IN OFF.
- Sorgente audio collegata all'ingresso IN 2 (Microfonico oppure di Linea) con modalità impostata MODE: IN OFF.

During a “Voice Alarm Condition”, the BGM sources are not operational.

“PA Source”:

One of the following audio sources using the “Voice” amplification channel for Public Address announcements:

- Source of sound connected to the IN 1 input (Microphone input), set in the ON or PRECEDENCE MODES.
- Source of sound connected to the IN 2 input (Microphone or Line input), set in the ON, VOX or PRECEDENCE MODES.
- EMERGENCY UNIT in the broadcasting mode, PAGING UNITS.

During a “Voice Alarm Condition” the PA sources are not operational.

“Emergency Source”:

One of the following audio sources, using the “Voice” and/or “Music” channels for emergency voice announcements (Voice Evacuation System):

- Pre-recorded Alert message (ALERT).
- Pre-recorded Evacuation message (EVAC).
- Emergency Microphone (P.T.T.) connected to the front-panel MICROPHONE socket.
- Emergency microphone station connected to the rear-panel EMERGENCY UNITS socket.

Activation of a “Emergency source” generates an operational “Voice Alarm Condition”.

“Priority”:

Use of the output zones by an audio signal or by a reset command is governed in the hierarchy by the level of priority assigned to each active source. A current activation of a zone can be interrupted only by another with a higher priority.

The VAC 2006 system manages priorities as shown in the following tables:

Priority	System condition	Operating environment	Priority level	Active source	For setting see MENU
high ↑ low	“Voice alarm condition”	Manual Emergency	15	VAC 2006 with emergency microphone	Fixed setting
			8 to 14	Emergency microphone stations	See the manual of FMD 2001 & FMD 2012 stations
		Automatic Emergency	7	CONTROL INPUT for RESET function	Fixed setting
			6	CONTROL INPUT for EVAC message	Fixed setting
			5	CONTROL INPUT for ALERT message	Fixed setting

Priority	System condition	Operating environment	Priority level	Active source	For setting see MENU
high ↑ low	“Quiescent condition”	PA Source	8 to 14	Emergency units in broadcast mode	See Emergency units manual
			1 to 7	Inputs IN 1 - IN 2 with the PRECEDENCE or VOX functions	See AUDIO SETTING section
				PAGING UNITS Microphone stations	See the manual of MBT 1106 & MBT 1112 stations
		0	Music source	Fixed setting	

The active sources in the “Voice Alarm” condition always have priority over those active in “Quiescent” condition, regardless of the priority level set.

5.2 EQUIPMENT AND FUNCTIONAL SPECIFICATIONS

5.2.1 VAC 2006 controller

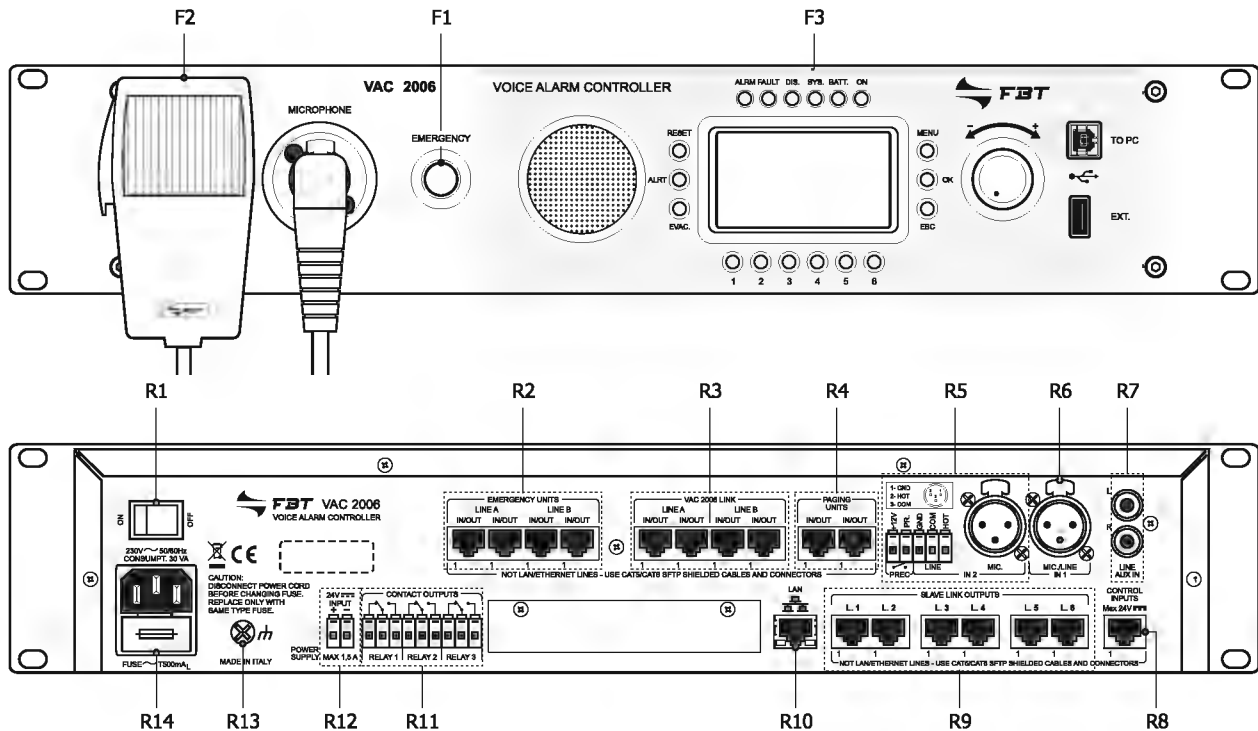

Front panel

F1. Emergency button with LED (red)

Flush-mounted push-button for activating the Manual Emergency mode. It enables access to the system, with top priority, from the "Quiescent condition" or during an Automatic Emergency, previously activated from an external peripheral unit. The LED, which is normally extinguished, will light up steadily in the Manual Emergency mode activated from the unit in question. If the LED flashes, this indicates a Manual Emergency status activated from an emergency microphone station or a remote controller. The Emergency button will also be used for exiting the Manual Emergency. The push-button is controlled by the internal diagnostics system.

F2. Emergency microphone

Hand-held microphone with Push-to-Talk (P.T.T.) key, for live emergency announcements. The microphone is only operational in Manual Emergency conditions and has priority over pre-recorded emergency messages. The microphone capsule is controlled by the internal diagnostic system. Use only the microphone included in the supply, connected directly, without any extension cable, to the XLR socket on the front panel of the VAC 2006.

F3. Graphic DISPLAY

Backlit black-and-white graphic display, 128x64 pixels, for displaying the many management windows, the contents of which will vary depending on the operating conditions of the system (quiescent or emergency). Together with the +/- knob and with the multi-purpose keys, it is useful for navigating through the menus, for adjusting working parameters and for managing advanced functions. It will also display all the information required concerning Fault, Disablement and Voice Alarm Conditions, that are not all signalled by the status LED's.

Rear panel

R1. POWER switch

ON/OFF switch of the VAC 2006 system. In the O (OFF) position, the system is switched off and in the I (ON) position the system is switched on. The switch affects only the main 230 VAC power supply (see the "Power Supply and Earthing" and "Safety Notes" sections for details about safety).

R2. EMERGENCY UNITS

Input for connecting remote emergency microphone stations. Use only the FMD 2001 and/or FMD 2012 microphone stations. RJ45 socket for connection with Cat. 5e SF/UTP cable with a shielding braid and shielded STP connector (for details of the connection, consult the manual of the FBT 37359 stations). The EMERGENCY UNITS must be connected to one another in daisy-chain fashion: each of the two connecting lines A and B can reach a total length of up to 1 km.

R3. VAC 2006 LINK Sockets for connections among VAC 2006 controllers (up to 6)

Connectors for connections among several controllers. If both LINK A and LINK B are used, a redundant connection is achieved that keeps the system in working order even if one of the two links fails. If more than one controller is installed on the same rack, it is possible to use a single LINK (A or B), if this is done, it is necessary to de-activate the remote link test not being used:

- o Path: HOME / CONFIGURATION / set> BACKGROUND TEST / 2-Voice Alarms / 6-Remote Link > Link Test

R4. PAGING UNITS

Input for connecting paging microphone stations (MBT 1106, MBT 1112) for broadcasting functions. It is possible to connect up to a total of 16 Paging Units. RJ45 sockets (2 off) for connection with Cat. 5e SF/UTP cable with shielding braiding and shielded STP connector. The connection with the Paging Units must be of the daisy-chain type. The two connecting lines can reach a total length between them of up to 1 km.

R5. IN. 2 – MIC. / LINE and PRECEDENCE TERMINAL STRIP

INPUT 2 is a balanced input for a microphone or an external source, programmable as a Music or Voice source. Use the MIC input to connect dynamic or electret microphones, enabling the phantom power supply or, as an alternative, the input on the terminal strip for sources at line level such as mixers or pre-amplified microphone stations. The input can be set in many different ways, depending on how the operating mode is programmed:

- as a Voice source enabled by the precedence contact (PREC.), with a CHIME that can be activated/de-activated.
- as a voice source for automatic VOX activation with adjustment of the activation threshold and of the release time and the possibility of an activatable/de-activatable CHIME.

When used as a voice source, the priority can be set with 7 different levels, and the group of paging zones can be selected.

Do not use simultaneously the MIC. and LINE inputs of the IN. 2 input but:

- the XLR F socket for connecting a balanced signal of up to 100 mV, or
- the socket with 3 terminals, HOT-COM-GND, for stripped wire, for connection of a balanced signal of up to 1.8 V.

In both cases, use shielded balanced microphone cable. For details concerning the settings of the IN. 2 input, refer to the information shown in the Music menu and under AUDIO SETTINGS > INPUT 2 and CHIME.

PRECEDENCE TERMINAL STRIP

Terminal strip for connecting the precedence contact to the current music source, for activation of the IN. 1 or IN. 2 inputs and of the CHIME, if enabled. The precedence function can be used in either of the 3 following ways. The precedence function can be used with MIC 1 or MIC 2 if it is enabled on their control panels. For details of the precedence settings, refer to the indications shown on the INPUT 1 and INPUT 2 panels and in the AUDIO SETTING menu. Activation is carried out keeping the +12 V terminal connected to the PR. terminal, by closing a dry contact or connecting the available precedence contact to table-top microphones.

R6. IN. 1 – MIC 1

INPUT 1 input for an external microphone, programmable as a Music or Voice source. It is possible to connect dynamic or electret microphones to this input, enabling the phantom power supply. Programming of the operating mode enables use as a voice source enabled by a precedence contact (PREC.), with the possibility of activating/de-activating a CHIME.

When it is used as a Voice source, it is possible to set priority, to 7 different levels, and the group of paging zones. The XLR -F socket enables a balanced signal of up to 100 mV to be connected, by means of shielded balanced microphone cable. For details concerning the settings of the IN. 1 input, refer to the indications contained in the INPUT 1 panel (point 8.3.4).

R7. LINE AUX IN

Input for connecting an external source of music. It has one pair of RCA sockets, with conversion to mono, for sources with unbalanced outputs at line level. For the audio settings of the AUX input, refer to the information contained in the MUSIC menu.

R8. CONTROL INPUTS

7 digital inputs for monitoring via external peripheral units. They enable programmed events to be activated, including switching of the VAC 2006 system to a Voice Emergency condition, requiring automatic sending of pre-recorded emergency messages. Activation is possible by means of Normally Open or Normally Closed contacts, relaying the +24 VDC voltage supplied from the service sockets. It is possible to enable diagnostics of the connecting stretch, arranging to install two 10-kOhm balancing resistors in the proximity of the contact for activating the remote peripheral unit. (see page 70).

R9. SLAVE LINK OUTPUTS

6 output lines for connection to DPU amplifiers and/or VAIE 2250 compact emergency systems and/or VAR 2006 routers.

R10. LAN

Socket for connecting an Ethernet 10/100 Local Area Network using the TCP/IP protocol.

R11. RELAY 1 – RELAY 2 – RELAY 3

3 relay outputs for signalling to external peripheral units. The VAC 2006 system enables the logical outputs to be programmed to link activation of the output with system status events or for override functions in connection with emergency conditions, or for signalling failures, emergencies and disabling. All the outputs can be programmed to be either Normally Active or Normally De-activated. The connection calls for 3 screw-down terminals for stripped wires for each relay, referred to N.O. and N.C. contacts - Changeover.

N.B.: Two outputs are available on the VAR 2006 router.

R12. Terminals for external 24 VDC power supply

Terminals for connecting the auxiliary 24 VDC power supply. This is not used when the 230 VAC mains power supply is available. The input is protected against inversion of the poles. Consult the "Power supply and earthing" and "Safety Notes" sections for details about safety. **N.B.: The batteries and the battery-charger must be installed on the same rack on which the VAC 2006 controller is mounted.**

R13. Frame connection

The frame connection may be used to connect other equipment only for the purpose of shielding the low signals. This terminal may not be used to connect the frame to earth for safety purposes. (Consult the "Power supply and earthing" and "Safety Notes" sections for details about safety).

R14. Plug for 230 VAC mains power with built-in fuse

Plug for connecting the equipment to the 230 VAC/50-60Hz mains power using the power cable supplied with it. If it is necessary to replace the mains fuse, this must be done with one of the same type, i.e. 500 mA fuse, of the miniature 20 mm cylindrical type. (consult the "Power supply and earthing" and "Safety Notes" sections on page 64 for details about safety).

5.2.2 VAR 2006 Router

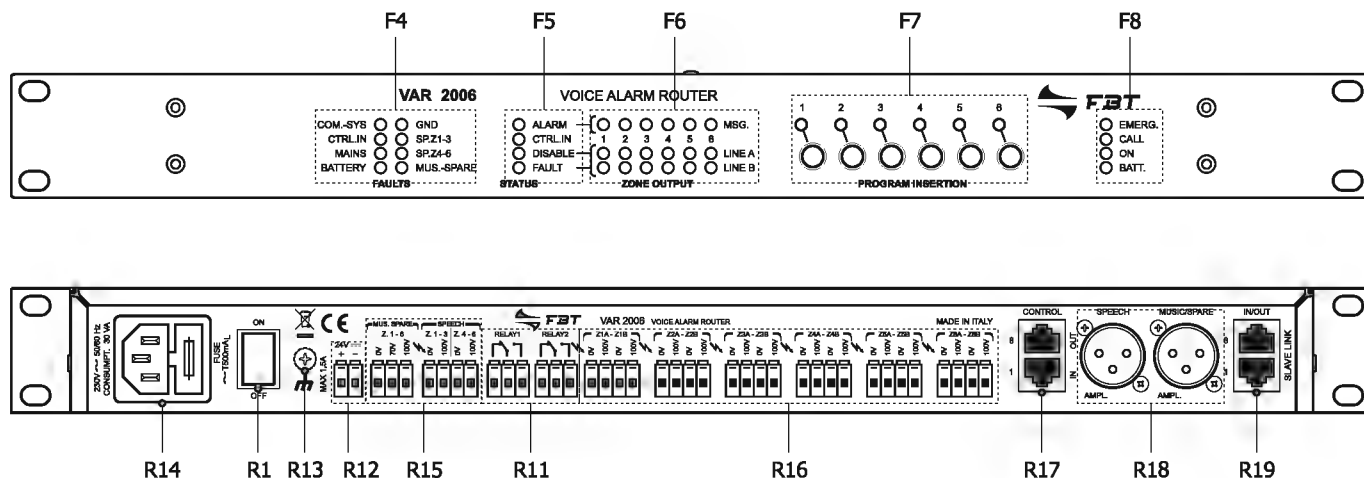

Front panel

F4. FAULTS LEDs

The FAULT LEDs provide the following information:

- COM-SYS Flashing indicates the absence of a connection with the controller.
- CTRL IN This indicates a failure of the controlled inputs.
- MAINS This indicates a failure of the internal power supply.
- BATTERY This indicates the lack of power from the battery.
- GND Ground Fault.
- SP. Z1-3 Failure of the amplifier connected to zones Z1 to Z3.
- SP. Z4-6 Failure of the amplifier connected to zones Z4 to Z6.
- MUS.-SPARE Failure of the music/spare amplifier.

F5. STATUS LEDs

The STATUS LEDs provide the following information:

- ALARM This indicates the presence of a (generic) emergency voice and/or recorded message being sent out.
- CTRL IN This indicates the presence of a emergency voice and/or recorded message from one of the input contacts being sent out.
- DISABLE This indicates the presence of at least one zone for which broadcasting of emergency messages is not envisaged.
- FAULT This indicates the presence of a failure on at least one of the 6 output lines.

F6. ZONE OUTPUT LEDs

The red MSG LEDs indicate in real time the zone(s) in which the emergency voice signal is being broadcast:

- Flashing* Warning message being sent out.
- Steady ON* Evacuation or live message being sent out.

The yellow LINE A/B LEDs indicate the following:

- Flashing* Zone failure: impedance measured on the zone is out of specifications.
- Steady ON* This indicates the zones in which broadcasting of emergency messages is not envisaged (DISABLE function).

F7. PROGRAM INSERTION

The LEDs indicate the following:

- Flashing* The zone in which a broadcast call (NOT an emergency call) is being sent out.
 - Steady ON* Background music is activated for this zone (this function is only possible if there is also an amplifier MUS.-SPARE).
- The push-buttons allow background music to be activated in the corresponding zones (this function is only possible if there is also a MUS.-SPARE amplifier).

F8. Status LEDs

Power supply/call status LEDs:

- EMERG. This indicates that the system is in a state of emergency.
- CALL This indicates that a broadcast call is being sent out.
- ON This indicates the presence of the 230 VAC power supply.
- BATT. This indicates the presence of the 24 VDC external power supply.

Rear panel

R1. POWER switch

See page 73.

R11. RELAY 1 – RELAY 2

2 relay outputs for signalling to external peripheral units (see page 74).

R12. Terminals for external 24 VDC power supply

See page 74.

R13. Frame connection

See page 74.

R14. Plug for 230 VAC mains power with built-in fuse

See page 74.

R15. MUSIC SPARE / SPEECH terminals

Terminal block for connection to the outputs of the voice and music/spare amplifiers. It is possible to set four different connection configurations.

R16. Terminals Z1A/B to Z6A/B

Power outputs for lines to speaker units. Use only speaker units with 100-V constant-voltage line repeating coils. Six output zones are available and each zone is split up into two lines, A and B, to create a loudspeaker network featuring double redundant lines. In the event of a short-circuit on one line, the VAIE 2250 system will de-activate the output for the failed line and will continue to power the other line of the same zone, activating a Failure signal. 12 pairs of screw-down terminals for wires having cross-sections of up to 2.5 mm² are available for connecting the 0V-100V lines.

R17. CONTROL sockets

- 7 monitored digital inputs for control via external peripheral units. These enable activation of programmable events, in Voice Emergency conditions, requiring pre-recorded emergency messages to be sent out automatically. Activation is possible via Normally Open or Normally Closed contacts, relaying the +24 VDC power supplied via the CONTROL socket. It is possible to enable diagnostics for the connecting line by installing two 10-kOhm balancing resistors in the proximity of the contact for activating the remote peripheral unit. This connection calls for a RJ45 socket with Cat. 5e SF/UTP cable.

- 6 open-collector outputs for driving generic external or peripheral relays. The VAIE system enables the logical outputs to be programmed to link activation of the output with system status events or for override functions in emergency conditions or for signalling failures relating to the current emergency and to the disablement. These outputs can be programmed as Normally Open or Normally Closed and they have internal 24 VDC voltage with automatically resetting protection devices. This connection calls for a RJ45 socket with Cat. 5e SF/UTP cable.

R18. SPEECH and MUSIC/SPARE microphone sockets

- SPEECH Connection to the voice amplifier(s).
- MUSIC/SPARE Connection to the music/spare amplifier.

R19. SLAVE LINK IN/OUT sockets

Input/output for connection to the corresponding sockets on the VAC 2006 controller (RJ45 socket with Cat. 5e SF/UTP cable).

5.2.3 Controller control panel

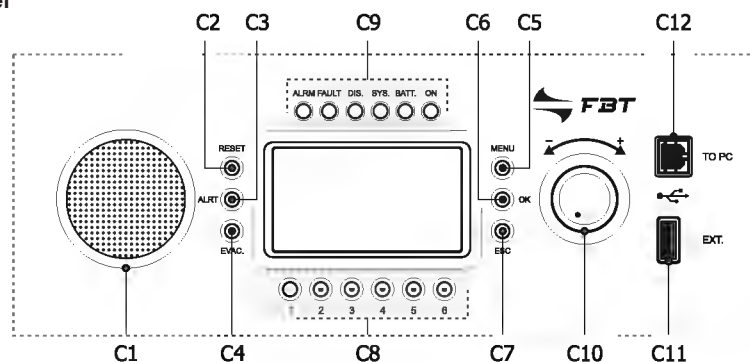

C1. Monitoring/beep loudspeaker

Built-in loudspeaker for signalling detection of failures (beep). The signalling tone will be automatically muted if the failure conditions cease to exist. Furthermore, in order to avoid triggering acoustic feedback, it will be muted by the system while the Emergency Microphone is being used.

C2. RESET button

Key for resetting the pre-recorded emergency messages manually, operational during Manual Emergencies. Key for resetting the buzzer and for cancelling signalling of the failure, operational when there is a failure present or after a failure has been cleared. In the idle condition, this key is not operational.

- C3. ALERT button**
Key for sending pre-recorded Alert messages manually, operation during Manual Emergencies. In the idle condition this key is not operational.
- C4. EVAC button**
Key for sending pre-recorded Evacuation messages manually, operational during Manual Emergencies. In the idle condition this key is not operational.
- C5. MENU key**
Multi-purpose key for accessing the Main Page, for navigating among the menus and for specific functions of the submenus indicated on the displays.
- C6. OK key**
Multi-purpose key for confirming selections, for navigating among the menus and for specific functions of the submenus indicated on the displays.
- C7. ESC key**
Multi-purpose key for returning to the Music menu, for navigating among the menus and for specific functions of the submenus indicated on the displays.
- C8. Numerical keys from 1 to 6**
Multipurpose keys, operational throughout the system. These keys are used to select the zones, from 1 to 6. For the VAC 2006 unit being used. They enable the access password to be entered or the specific functions indicated on the status bar on the display to be applied.
- C9. Status signalling**
- **ALARM LED (red)**
LED for signalling the existence of a "Voice Alarm Condition". A VOICE ALARM condition can be activated both automatically from an external peripheral unit, and manually by the operator of the VAC 2006 or of an emergency microphone station. During the VOICE ALARM condition, the standard functions for playing out music and the voice source service are disabled. In the "Quiescent condition" the ALARM LED is extinguished.
 - **FAULT LED (yellow)**
LED for signalling the existence of a "Fault condition". This indicates that the diagnostic system has detected at least one failure in the VAC 2006 unit or in one of the items of equipment connected to it and covered by the diagnostic procedure. When the fault condition is cleared, the FAULT LED extinguishes automatically and the wording "RES" is shown on the FAULTS display, to show that a failure has been detected and subsequently remedied (RESUMED). The LED signalling that the fault has been cleared will extinguish once the MANUAL FAULT RESET procedure has been completed. The FAULT signalling can be active during the standard functions of music and voice reproduction (Quiescent Condition) and Emergency (Alarm Condition).
 - **DIS. LED (yellow)**
LED for signalling activation of the disablement of the emergency zones (DISABLING). The DISABLING signal indicates that at least one zone has been disabled by the emergency envisaged when configuring the system. Activation of the DISABLING signal does not prevent normal operation of the system in a "Quiescent Condition".
 - **SYS LED (yellow)**
LED for signalling an existing "System Fault" (System CPU Fault) condition. When the SYS LED is illuminated, all the operational functions, whether of the standard or emergency type, are disabled.
 - **BATT. LED (green)**
This LED refers to the 24 VDC auxiliary power supply. The BATT. LED lights up to indicate that the 24 VDC power supply is connected to the system.
 - **ON LED (green)**
This LED signals that the VAC 2006 system is switched on and operational.
The ON LED continues to be illuminated when:
 - 230 VAC power supply present and POWER switch in the ON position.
 The ON LED will flash continuously when:
 - there is no 230 VAC power supply but the 24 VDC power supply is available.
 The ON LED will be Off in the following cases:
 - no 230 VAC and no 24VDC power supply, or
 - 230 VAC power supply in order, no 24 VDC power supply and POWER switch in the OFF position.
- C10. +/- knob**
This is a rotary control with no end-of-travel. It is a multi-purpose control that depends on the specific menu that is operational. It is used to move the cursor to select and adjust values. In an idle condition, in the Music menu it is used to control directly the master output volume of the BGM.
- C11. "EXT." USB socket**
Powered type A USB socket for connecting external flash memory devices (for future use).
- C12. "TO PC" USB socket**
Type B USB socket, provisions for connecting the management PC in order to use the system software.

6. CONFIGURATION OF THE SYSTEM

6.1 INTRODUCTION

The Controller Manager software enables the whole system you wish to create to be compiled and configured. To start running the programme, click twice on the "controller.exe" file.

N.B.: In order for the programme to work correctly, the operating system of the PC must be Windows 7® or higher.

6.2 CREATING A NEW PROJECT FILE

Once you have started the programme. You can already create a new system configuration.

To create the new file, select **File > New Project** on the menu bar.

To add a description to the project, select **Project > Edit Description** and enter it in the field provided (max 22 digits).

To save the new project, select **File > Save Project As**: use the dialogue box to assign a name to the project and identify or create a destination folder. The status bar at the bottom of the window will show that the operation has been completed successfully.

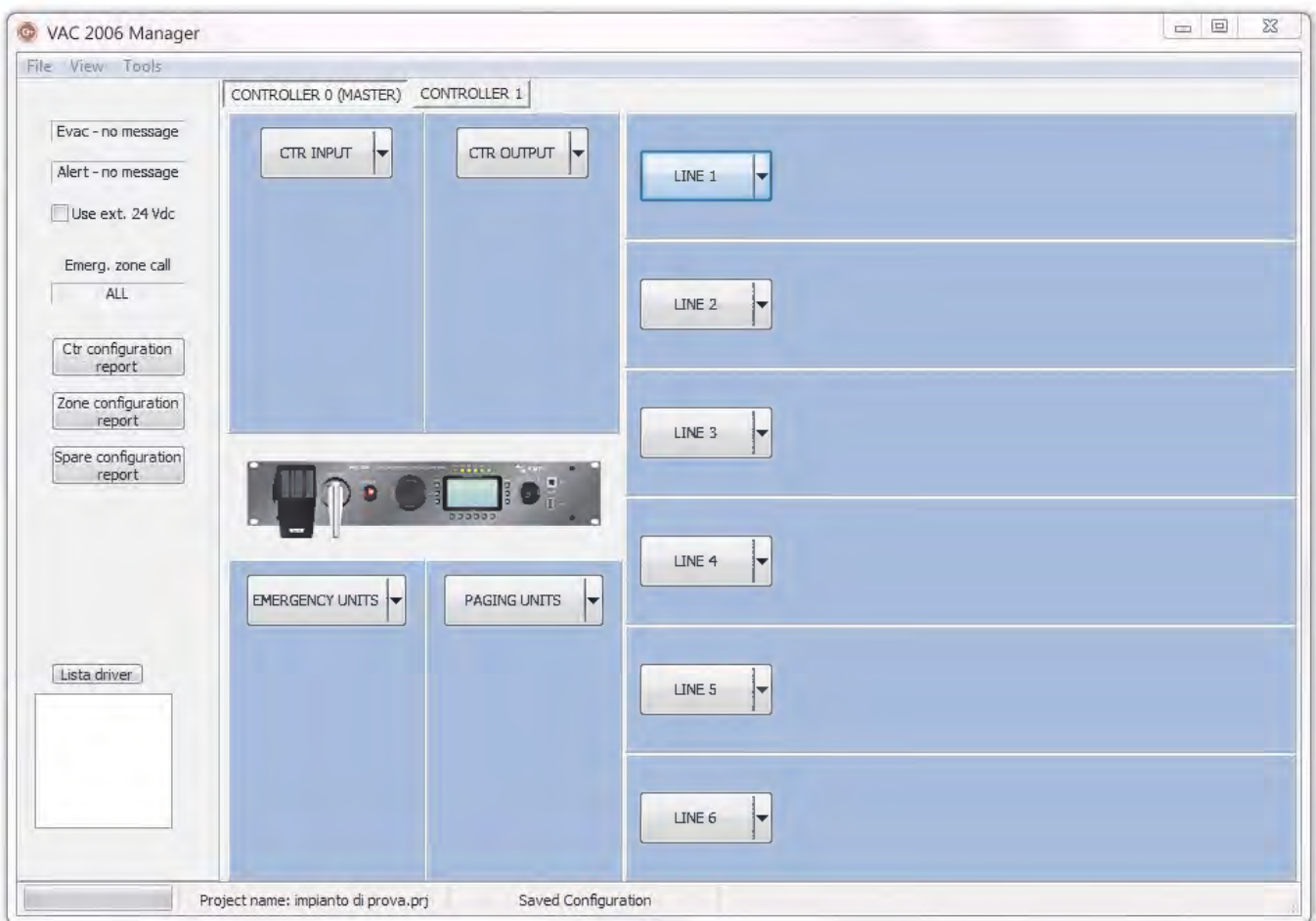

Once this has been done, you can start to configure the system.

To save an open project simply select **File > Save Project***.

6.3 OPENING AN EXISTING PROJECT

To open a previously saved project, select **File > Open Project**; in the dialogue box, select the folder and the desired *.prg file.

* It is possible at any time to compile a new project by selecting **File > New Project**. Of course all the previously entered data will be lost since the programme will start again from an empty project.

6.4 INSERTING THE CONTROLLERS

From the Tools menu, select **Tools > Insert Controller** and add the number of VAC 2006 units in the system (in the example, there are two of them).

The controller with the address “0” is factory-set as the “Master”, and there must be one in each project.

6.5 CONFIGURING THE CONTROLLER

Now configure the single lines for each controller, starting from the Master and setting the parameters for line 1.

Press **LINE 1 > Configure**: A window will open in which you can select the equipment that is connected to this line (none, VAR 2006 router, DPU amplifiers or a VAIE 2250 compact system).

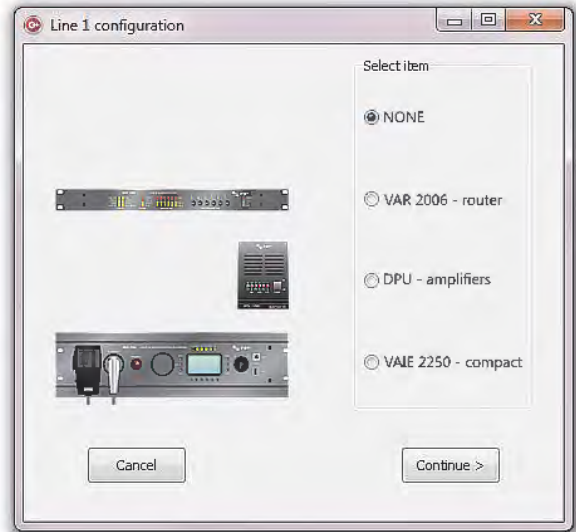

Select the required option and click on **Continue >**.

Each option leads to a specific dedicated window, except for “NONE”, which returns the line to an unused condition.

• VAR 2006 - router

If you select this item, the *Line 1 configuration* window will open, in which you can select the features of the zones and the input and output contacts of the router. You can also indicate the presence of amplifiers connected to it. Once you have set the parameters, press *End* (or *Cancel* to exit without saving the changes made).

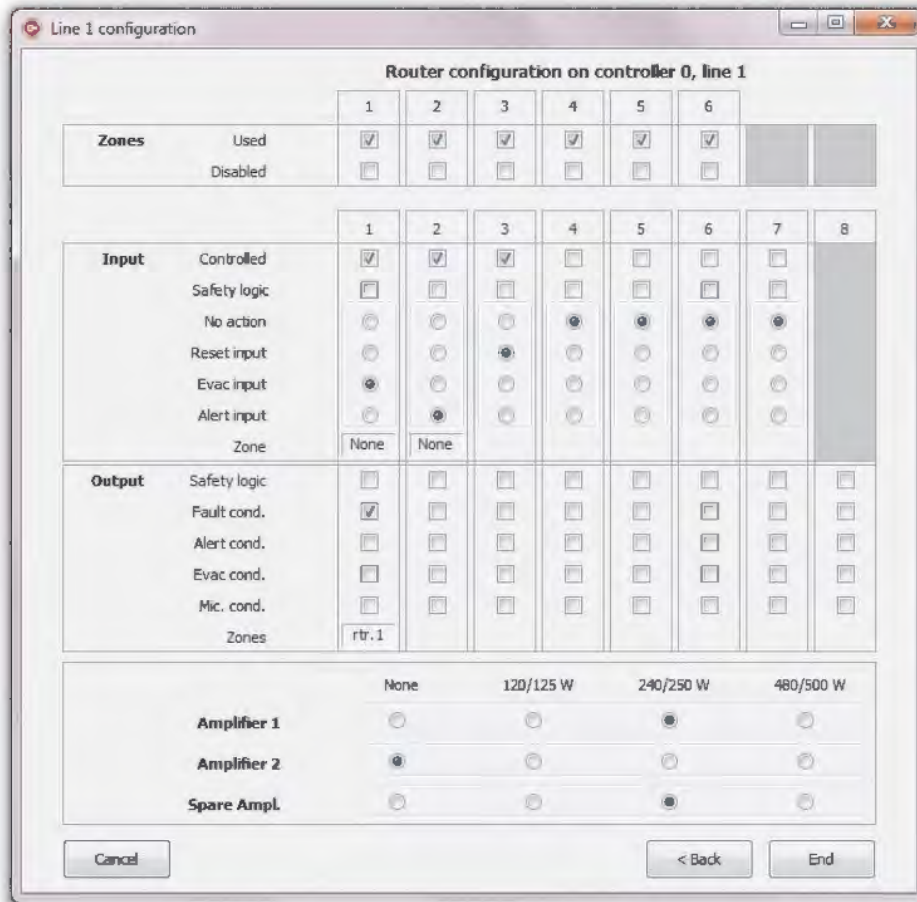

You can find a brief summary of the settings made by clicking on **LINE 1 > Report**.

• DPU amplifiers

IMPORTANT NOTICE!

All the amplifiers connected to a line must necessarily have progressive addresses, from number 1 onwards (max 16 for each line). To set the address of each single amplifier, consult the "Settings" section in the instruction booklet of the DPU range (FBT code number 37784).

Supposing you wish to set line 2 for connection to amplifiers of the DPU range: after pressing **LINE 2 > Configure** and selecting *DPU - amplifiers* the *Line 2 configuration* window will open.

In this window it is possible to list the amplifiers (and their models) connected to the lines in question, in addition to indicating whether they are stand-by amplifiers. The associations between the various different amplifiers and the standby units as selected under the heading "Configuring the standby amplifiers" (Page 83) are also highlighted. The programme will guide you through the procedure in order to ensure that several rules are followed:

- The entries are sequential, starting from address 1. If an amplifier half-way down the list is deleted by selecting *model = "none"* as the model, therefore, all the amplifiers with the next addresses will also be removed.
- One line can manage up to a maximum of two standby units. The first of these is "global", that is to say it can replace the amplifiers of any other line of the controller. The second standby unit can be either:
 - "global" if there are only two standby units on the lines; or
 - "local" if there are additional amplifiers on the line. In this case, the standby unit can only replace amplifiers belonging to the same line as the unit itself.

The programme carries out cross-checks to ensure that the compilation is correct.

Once you have completed the compilation, press **End** to save the configuration, which will appear associated with line 2 in the main window. As an alternative, you may press **Cancel** to exit without saving the changes made.



• VAIE 2250 compact system

For line 3, set a connection to a VAIE 2250 compact system: after pressing **LINE 3 > Configure** and selecting the item *VAIE 2250 - compact* the *Line 3 configuration* window will open.

Once you have set the parameters for all the lines, go on to compile the other four connections shown in the main window: CTR INPUT, CTR OUTPUT, EMERGENCY UNITS and BROADCASTING UNITS.

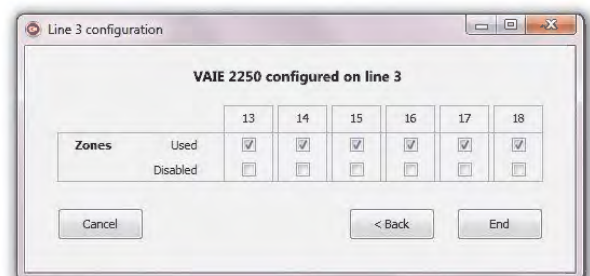

• **CTR INPUT**

Press **CTR INPUT > Configure**. The Controller 0 input configuration window will open, in which you can associate the required parameters with each of the 7 contacts.

Press *End* to save the configuration, or press *Cancel* to cancel it and return to the main window.

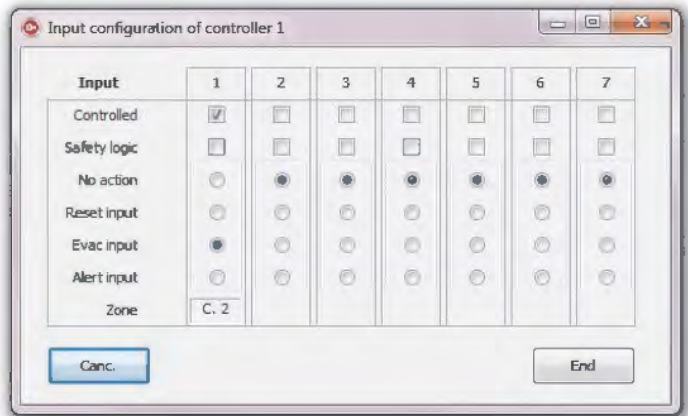

• **CTR OUTPUT**

Press **CTR OUTPUT > Configure**. The Controller 0 output configuration window will open, in which – as already seen for the inputs – you can associate the required parameters with each of the 3 contacts.

Press *End* to save the configuration, or press *Cancel* to cancel it and return to the main window.

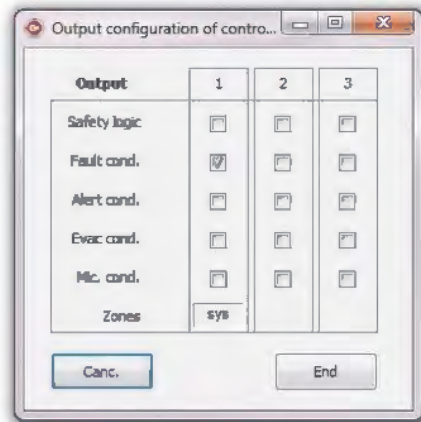

• **EMERGENCY UNITS**

Press **EMERGENCY UNITS > Configure**. The window for configuring the emergency stations that can be connected will open.

To set a specific configuration for the keys associated with each emergency station, press the relevant *Key Conf.*: It is possible to call up a configuration that has already been defined (see “Configuring groups of zones”) or to make changes manually to the default configuration prompted in the ‘Unit key list’ box.

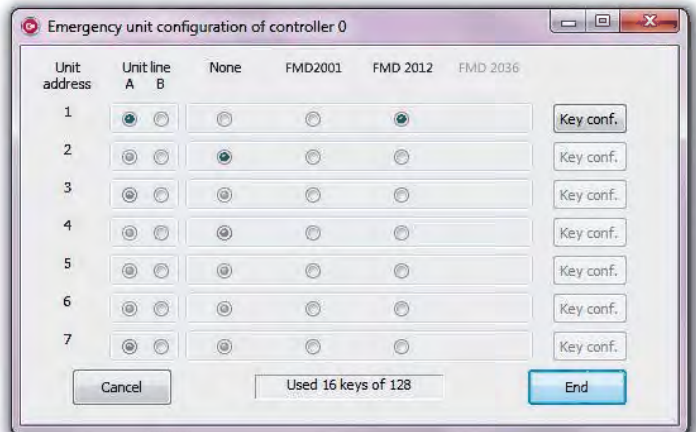

Press *End* to save the configuration, or press *Cancel* to cancel it and return to the main window.

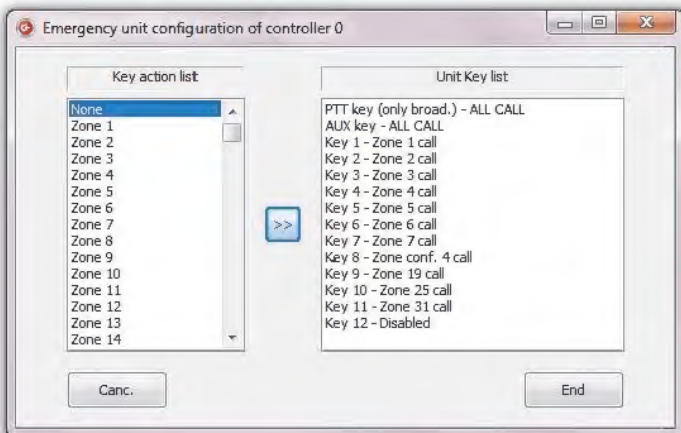

• **PAGING UNITS**

Press **PAGING UNITS > Configure**. The broadcasting call station configuration window will open.

To set a specific configuration for the keys associated with each emergency station, press the relevant *Key Conf.* It is possible to call up a configuration that has already been defined (see “Configuring groups of zones”) or to make changes manually to the default configuration prompted in the ‘Unit key list’ box. To do this, from the list on the right-hand side, select the key for which you wish to change the setting. From the list on the left-hand side, select the zone or the configuration you wish to associate with it, then click on the central arrows. The new combination selected by you will appear immediately on the list on the right-hand side.

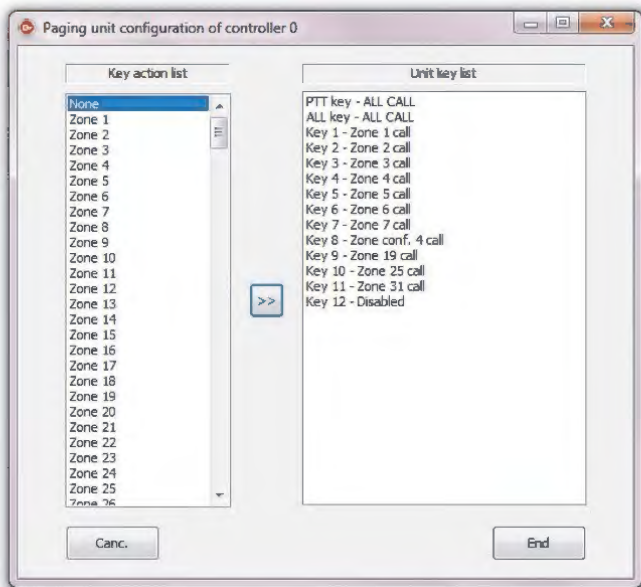

Press *End* to save the configuration, or press *Canc.* to cancel it and return to the main window.

• **Configuring groups of zones**

From the menu, select **View > Key configuration** to open a complete schedule of the zones referred to the controllers installed in the system. Against a white background, the window will show the number of units and zones that have been set. For each controller, the active zones are shown in **red**. The status of each zone can be altered simply by clicking on the number, which will turn **green**.

After setting the zones you require, click on Save to save the configuration. To create the next configuration file, select the name in the drop-down menu as before. In this window, you can set up to 64 configuration files, which you can call up in the configuration windows of the stations (see previous sections).

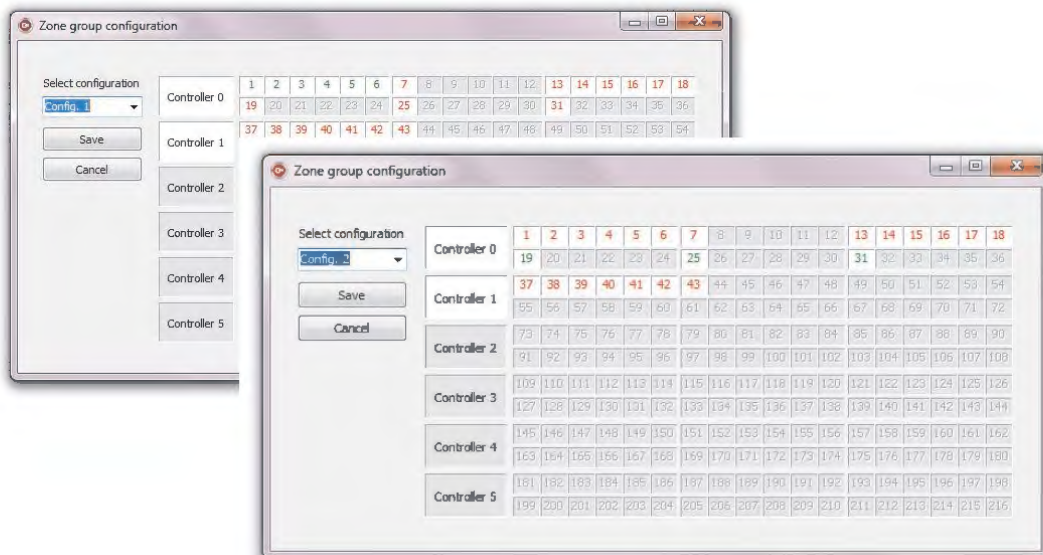

• Configuring the standby amplifiers

From the menu, select **View > Spare configuration** to open a complete schedule of all the amplifiers installed in the system.

In the window, the left-hand column shows the DPU amplifiers entered previously in the configuration file as standby units. For each of these, it is possible to indicate the amplifiers they will replace in the event of a failure. To do this, select the amplifier in the drop-down menu and click on 'Add' to associate it with its standby unit.

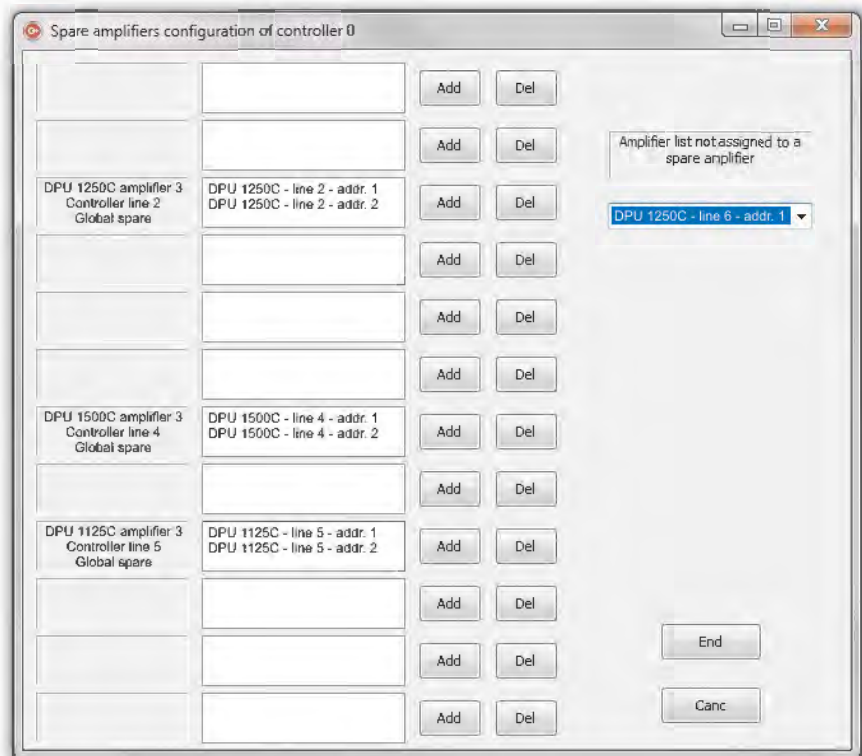

• Compiling voice messages / warning signals

From the menu, select **View > Message Compiler** to open the window enabling management of the pre-recorded voice messages and of the warning signal, if any. Click on **Path > Add file** and load the required *.wav file.

N.B.. The files to be used must necessarily be recorded in and /or converted into the *.WAV 48 ksampl 16bit audio format.

Once you have loaded the file, you can indicate whether it is a message to be sent in warning situations (Alert) or in evacuation situations (Evac).

It is also possible to add a brief description of each message entered (max 25 digits).

In addition to voice messages, a warning tone (Chime) can also be entered, using the same procedure.

Press **End** to save the configuration, or press **Cancel** to cancel it and return to the main window.

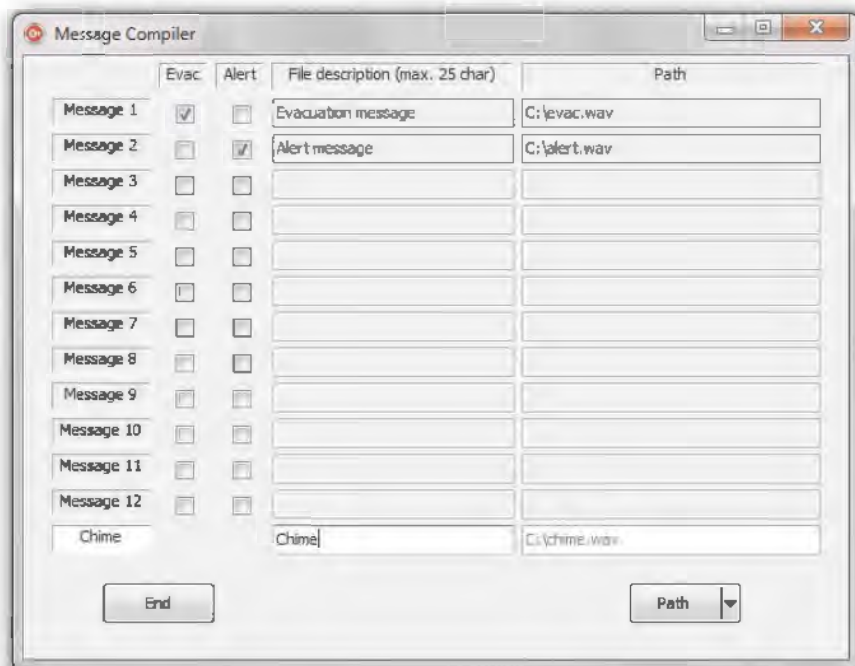

Once you have completed configuring CONTROLLER 0, save the project and click on the "CONTROLLER 1" tab to proceed with its configuration.

At this point, the main window of the programme will show most of the settings made:

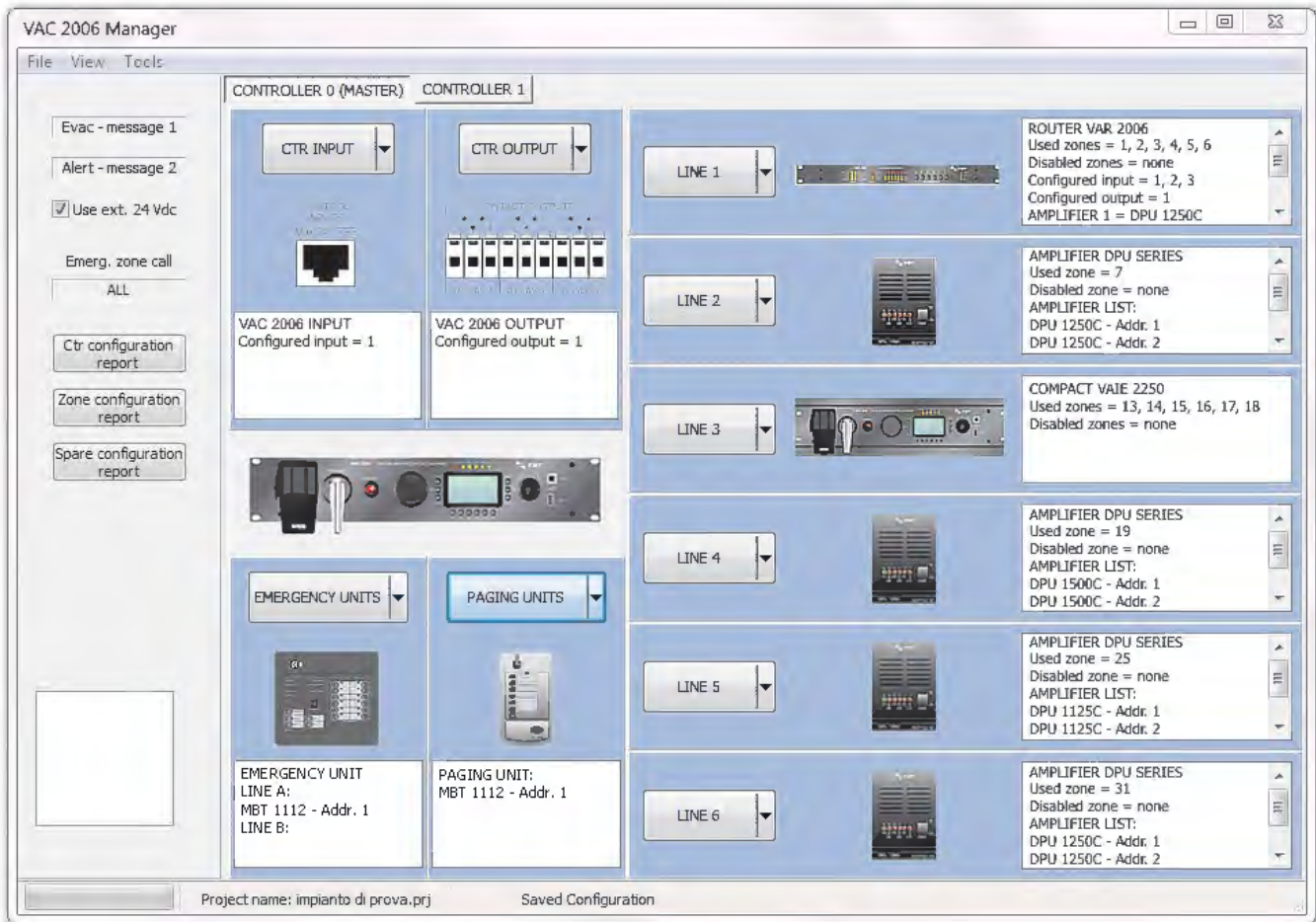

It is possible to obtain a complete printable report of all the settings simply by clicking on 'Ctr configuration report', 'Zone configuration report' and 'Spare configuration report'.

• Creation of an SD card

Once you have completed all the configuration activities, all the information must be downloaded to an SD card, which will then be plugged into the appropriate controller. **One SD card must be created for each controller in the system. Each single card will contain the information relating both to the specific controller and to the rest of the system.**

After making sure that CONTROLLER 0 is switched off, use a screwdriver to unscrew the small cover at the centre of the rear panel and remove it.

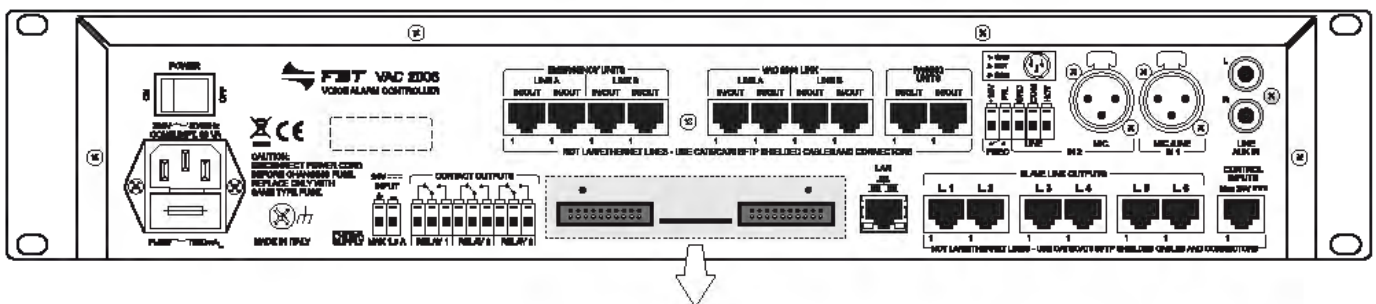

Insert the SD into the drive of the PC, then select the CONTROLLER 0 window. From the main menu, select **Tools > Create SD**. The card will be formatted and then automatically programmed with the necessary data.

Once writing has been completed, remove the SD card from the PC, then plug it into its slot in the rear panel of CONTROLLER 0. Put the cover back into place and fix it with the screws removed earlier.

Repeat these operations for all the other controllers (in the example, CONTROLLER 1).

7. MENU STRUCTURE

The **VAC 2006** enables access to the system functions through a set of Management Panels, grouped according to operational typologies and intended uses into Option Menus accessible from the Main Page. Furthermore, the following Option Menus were assigned to different levels of access, with reference to the various different circumstances requiring different degrees of skill on the part of the personnel and different levels of authorisation.

- **< MUSIC >** Menu

Default window for using the system in normal Quiescent Conditions. It enables control of the BGM sources and adjustment of the volumes of the music section. This menu is not accessible during a Voice Alarm Condition. At this basic level, the RESET, ALERT and EVAC keys are not operational.

- **< AUDIO SETTING >** Menu

Group of basic options for standard operating conditions. It is intended for users for setting and adjusting the PA sources. At this basic level, the RESET, ALERT and EVAC keys are not operational.

- **< INSPECTION >** Menu

First access level, for investigating the status of the system. It is intended for the personnel responsible for initial checking of the causes leading to a failure or emergency condition. At this initial access level, the RESET key has the function of resetting the buzzer signalling a FAULT. At this basic level, the ALERT and EVAC keys are not operational.

- **< OPERATOR >** Menu

Second access level for trained personnel, authorised to manage the system in emergency, failure and disablement conditions. A password for accessing this level can be added.

- **< CONFIGURATION >** Menu

Third access level, for trained personnel authorised to use the advanced functions of the system and to alter the configuration parameters, for starting up and altering the system. A password for accessing this level can be added.

- **< SERVICE >** Menu

Fourth access level, included among the options of the CONFIGURATION Menu, for servicing activities, up-dating of firmware and altering the operating parameters of the **VAC 2006** controller. Use is permitted only for technical personnel having the necessary access key.

- **< EMERGENCY >** Menu

Operational environment for managing Manual Emergencies, with top priority. Accessible at all times using the dedicated "Emergency" key, it may be used only by authorised personnel trained with regard to the Emergency and Evacuation Plan (EEP).

The functions associated with levels featuring restricted access, for which a password may be set, are highlighted by the symbol 

7.1 "HOME" FUNCTIONS - ACCESS TO THE OPTION MENUS

7.1.1 Basic Level - MUSIC menu

After switching on the system, the MUSIC Management Window will be shown directly. To access the HOME page, press the MENU key. From the HOME page it will be possible to select the various different Option Menus for the advanced functions of the system. From the HOME page, press ESC to return to the MUSIC management panel.

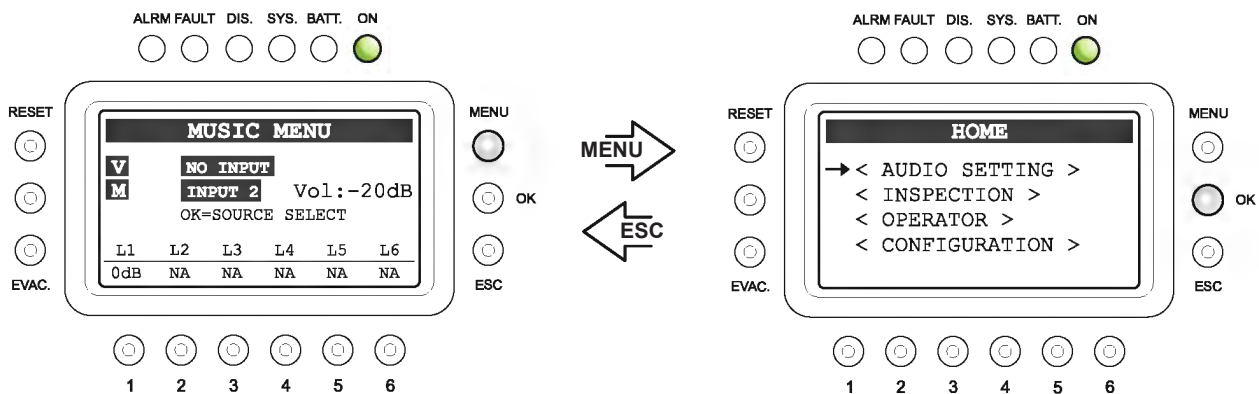

7.1.2 Basic Level - AUDIO SETTINGS Menu

From the HOME page, press OK to select AUDIO SETTING and access the menu in question. From the AUDIO SETTING menu, use the knob at the side of the display unit to browse through the options listed, then use OK to select the one you require. Press ESC to return to the MUSIC menu or MENU to return to the HOME page. **For the specific features of each panel for managing the AUDIO SETTING menu, refer to the appropriate schedules in Section 8. USING THE SYSTEM / 8.3 < AUDIO SETTINGS Menu >.**

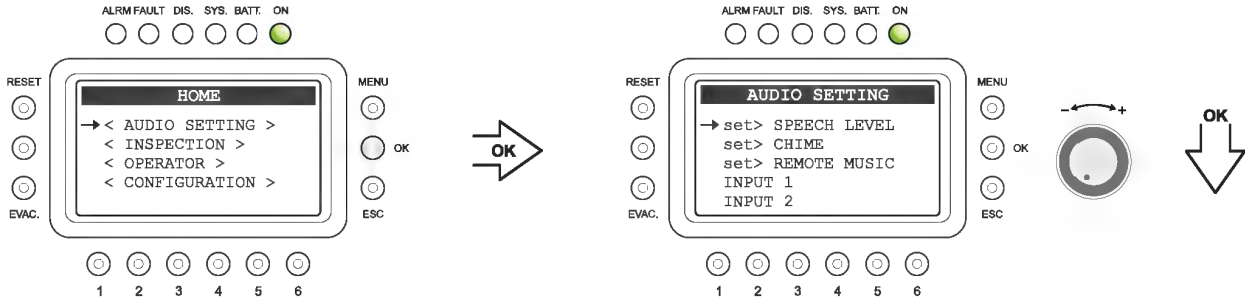

7.1.3 System Level - INSPECTION Menu

From the HOME page, turn the knob then press OK to select the item INSPECTION and access the menu in question. From the INSPECTION menu, use the knob at the side of the display unit to browse through the options listed, then use OK to select the one you require. Press ESC to return to the MUSIC menu or MENU to return to the HOME page. **For the specific features for each panel for managing the INSPECTION menu, refer to the appropriate schedules in Section 8. USING THE SYSTEM / 8.4 < INSPECTION Menu >.**

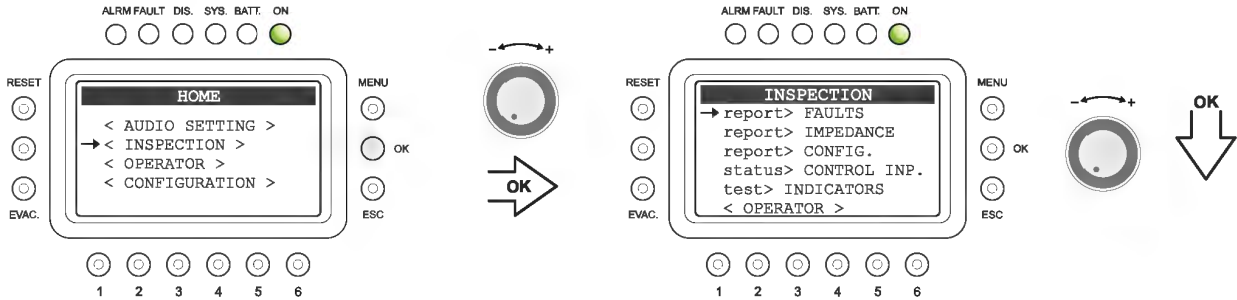

7.1.4 System Level - OPERATOR Menu

 From the HOME page, turn the knob, then press OK to select the item OPERATOR: to access the menu in question it is necessary to enter a password and then press OK again. As an alternative press ESC to return to the MUSIC menu.

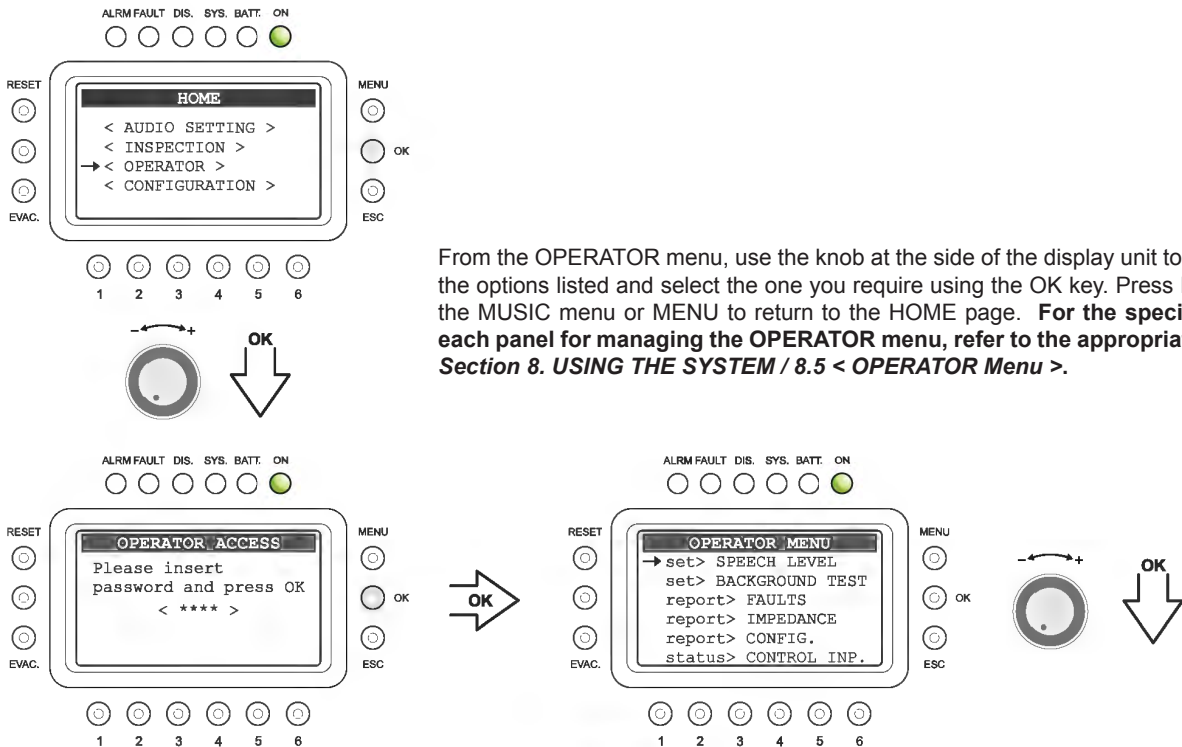

From the OPERATOR menu, use the knob at the side of the display unit to browse through the options listed and select the one you require using the OK key. Press ESC to return to the MUSIC menu or MENU to return to the HOME page. **For the specific features for each panel for managing the OPERATOR menu, refer to the appropriate schedules in Section 8. USING THE SYSTEM / 8.5 < OPERATOR Menu >.**

7.1.5 System Level - CONFIGURATION Menu

 From the HOME page, turn the knob, then press OK to select the item CONFIGURATION: to access the menu in question it is necessary to enter a password and then press OK again. As an alternative press ESC to return to the MUSIC menu.

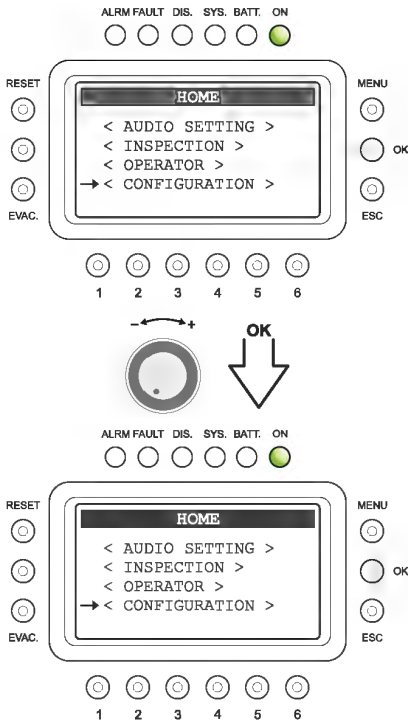

From the CONFIGURATION menu, use the knob at the side of the display unit to browse through the options listed and select the one you require using the OK key. Press ESC to return to the Music menu or MENU to return to the HOME page.

For the specific features for each panel for managing the CONFIGURATION/SERVICE menu, refer to the appropriate schedules in Section 8. USING THE SYSTEM / 8.6 < CONFIGURATION menu >.

7.1.6 System Level - SERVICE Menu

 Access the CONFIGURATION menu then use the knob at the side of the display unit to scroll to the <SERVICE> option and press OK to select it. To access the menu in question it is necessary to enter another password and then press OK again. As an alternative press ESC to return to the MUSIC menu.

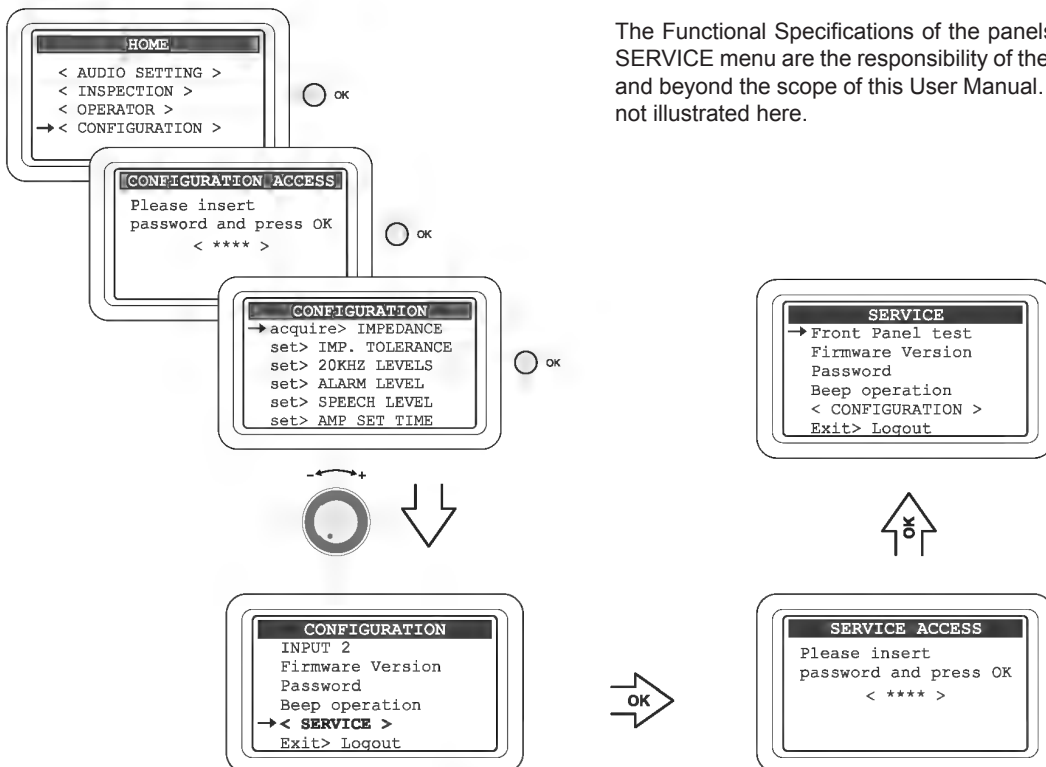

The Functional Specifications of the panels for managing the SERVICE menu are the responsibility of the Service personnel and beyond the scope of this User Manual. They are therefore not illustrated here.

8. USING THE SYSTEM

After making all the connections as indicated in Section 4, *Connections*, start the **VAC 2006** by turning ON the POWER switch (**R1**). The display will light up and show the panel of the MUSIC menu, from which you can access the HOME page pressing MENU.

If the system is being used for the first time, or if the configuration has been changed, proceed according to the indications shown in the section **8.1 Initialising the system**. If the initialise procedure is complete, see the instructions of the following sections:

- For normal use of background music and voice announcements, users can use just MUSIC and AUDIO SETTING menu.
- For the management of advanced features during fault, emergency and configuration condition, see the following menu INSPECTION, OPERATOR, and EMERGENCY CONFIGURATION.
- To reset the "beep", consult the OPERATOR Section (point 8.5.3.1, page 103).
- To send emergency messages, consult the MANUAL EMERGENCY Section (point 8.7, page 110).

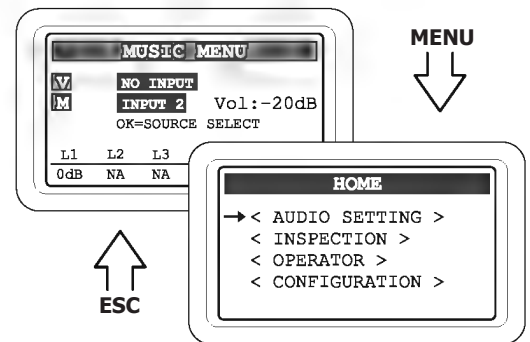

The functions associated with levels featuring restricted access, for which a password may be set, are highlighted by this symbol.

8.1 INITIALISING THE SYSTEM

The project of the audio system must be implemented with the help of the specific software (see Section 6, “*Configuring the system*”, on page 78).

• Password

From the HOME page, select the CONFIGURATION menu and press OK to confirm your choice. If the restriction calling for access with a password has been enabled, the “CONFIGURATION ACCESS” screen will appear: enter the 4-digit code of the password, then press OK to confirm (the default password is **3333**, see page 106).

• Resetting the BEEP

Failure signals may occur during the initialisation procedure due to the differences between the configuration of the system as connected and the default settings. To reset the acoustic signal (beep), access the “Report> FAULT” menu and press the RESET key. For details consult “FAULT” (point 8.5.3.1, page 105).

o **Path:** HOME / CONFIGURATION / report> FAULT (press RESET key).

• Acquisition of impedances

From the MUSIC menu, set all the outputs with music “OFF”. For details, see “MUSIC menu” (point 8.2.4, page 90).

Acquire the new loading impedances of the loudspeaker lines, as indicated under “IMP. ACQUISITION” and enable the test by setting the measurement tolerances.

o **Path:** HOME / CONFIGURATION / set> TOLERANCE / SET TOLERANCE

o **Path:** HOME / CONFIGURATION / acquire> IMPEDANCE / IMP. ACQUISITION (press the OK key)

• Diagnostics for 24 VDC power supply

If the auxiliary 24 VDC power supply has been connected, enable the diagnostic test by setting “24 VDC P.S. ON”, as illustrated under “BACKGROUND TEST” (point 8.5.2.3, page 104).

o **Path:** HOME / CONFIGURATION / set> BACKGROUND TEST / 4-Power supplies

• Emergency messages

The emergency messages are stored on the SD card using the dedicated software (see page 83).

• Input contacts

Use the dedicated software to programme the input contacts in the appropriate manner on the basis of the Emergency and Evacuation Plan (E&EP) (see page 81).

o **Path:** HOME / CONFIGURATION / set> CONTROL INPUTS

• Output contacts

Use the dedicated software to programme the output contacts in a suitable manner, on the basis of system specifications, if any (see page 81).

o **Path:** HOME / CONFIGURATION / set> CONTROL OUTPUT

• Volume control

Adjust the output volume of the Emergency sources suitably so as to ensure that the messages are as intelligible as possible. The level set will be used for “Voice Alarm Conditions” and will be the same for all the zones. To adjust the volume of the Emergency Microphone and of the ALERT and EVAC messages, follow the instructions provided under “ALARM LEVEL” (point 8.6.4, page 109).

o **Path:** HOME / CONFIGURATION / set> ALARM LEVEL

• Resetting failures

Upon completion of the system configuration, the reports concerning failure that have been stored and cleared should be cancelled (RESOLVED). A FAULT RESET should therefore be carried out as indicated under “FAULTS” (point 8.5.3.1, page 105).

o **Path:** HOME / CONFIGURATION / report> FAULT, access the subpanels for viewing failures

• After initialising the system

After completing the system initialisation procedure, LOG OUT in order to reinstate any access restrictions associated with passwords (point 8.5.5, page 105).

o **Path:** HOME / CONFIGURATION / Exit> Logout (press the OK key).

8.2 <MUSIC> MENU

Setting the audio parameters of the BGM sources

Music source control panel, shown by the VAC 2006 in normal “Quiescent Condition”.

• Navigation keys

MENU: For accessing the MAIN page

OK: For selecting a source of BGM

KEYS 1 to 6: For selecting music zones

RESET: Not operational

ALERT: Not operational

EVAC: Not operational

• Indications on the display

A) General output volume of the BGM Source

B) Status labels of each of the 6 zones:

OFF Music disabled

ndB Music enabled with the associated output volume

CALL Call in progress from a “voice” source (PA Source).

NA Line not active.

C) BGM Source selected for the “music” channel.

D) PA Source active on the “voice” channel for service announcements.

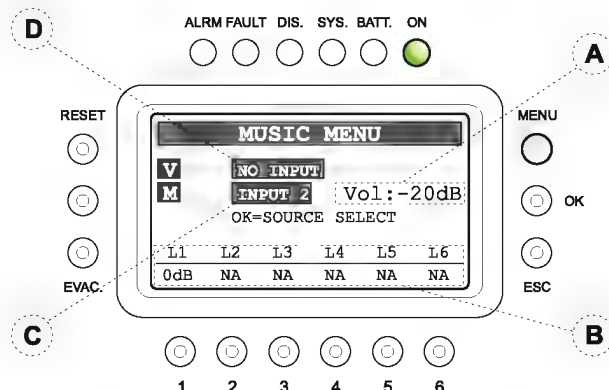

8.2.1 Selection of a BGM Source for the “music” channel

Press **OK** to select the required source of music from among the following:

- **AUX** Microphone source connected to the LINE AUX IN input (R7).
- **REMOTE** Source selected by the secondary VAC 2006 via the VAC 2006 LINK socket (R3).
- **INPUT 1** Microphone source connected to the IN 1 input (R6).
- **INPUT 2** Microphone source connected to the IN 2 input (LINE or MIC sockets) (R5).
- **NO INPUT** No input selected.

8.2.2 Overall volume control of the “music” channel BGM Source

- Use the +/- knob to adjust the volume.

The attenuation setting is visible directly on the display (A), with variations of 1 dB.

The volume that is set is stored for each BGM Source selected.

8.2.3 Adjustment of the music volume for each output zone

- Hold the numerical key of the required zone (from 1 to 6) down and turn the +/- knob.

The output volume is adjustable to any of 5 levels of attenuation in respect of the master volume (A); the attenuation steps are as follows:

-15dB (maximum attenuation), **-9dB**, **-6dB**, **-3dB**, **0dB** (no attenuation).

The volume that is set refers only to the “Music” channel.

N.B.: Adjustment is not possible on those lines to which an VAR 2006 router is connected.

8.2.4 Activation and de-activation of music for each output zone

- Press and then release the numerical key of the required zone (from 1 to 6).

The status label (B) will switch between **OFF** (music disabled) and **ndB** (music **ON** and associated output volume).



Note: The VAC 2006 system enables service announcements to be made from a PA Source to the required zones while continuing to broadcast music to all the other zones not affected by the call. When an announcement is being made, the display will show the source that is being used on the voice channel (D), and the status label of each zone selected (B) will indicate the word **CALL**.

Service announcements will be broadcast at the volume set for the input of the PA Source (see **AUDIO SETTINGS** menu) and if appropriate will also be sent to the zones for which music is de-activated (**OFF**).

8.3 < AUDIO SETTING > MENU

Setting the audio parameters of the PA sources

Menu for accessing the panels for managing the audio parameters of the music and voice sources.

Turn the knob to browse through the items listed and select the required item. Then press OK to confirm, or:

- Press MENU to return to the HOME page.
- Press ESC to return to the MUSIC menu.

The options of the AUDIO SETTINGS menu enable the following panels to be accessed:

8.3.1 set> SPEECH LEVEL

Volume control for the voice sources connected to the VAC 2006.

8.3.2 set> CHIME

Volume control and assignment of voice sources for the CHIME.

8.3.3 INPUT 1

Volume control and setting of the operating mode of the IN 1 input (MIC.).

8.3.4 INPUT 2

Volume control and setting of the operating mode of the IN 2 input (MIC. or LINE).

8.3.1 Set> SPEECH LEVEL

Management of voice sources

Panel for setting the levels of the voice sources connected to the VAC 2006:

- 1- Emerg. unit** Emergency stations of the FMD range.
- 2-Broad. unit** Broadcasting stations of the MBTrange.
- 3-Mic 1 input** Microphone connected to the MIC 1 IN socket.
- 4-Mic 2 input** Microphone connected to the MIC 2 IN socket.
- 5-From remote** Other controllers connected to the LINK sockets on the VAC 2006.

• Volume control:

Hold down the numerical key corresponding to the source then turn the +/- knob to adjust the volume (range -80 to 0 dB).

8.3.2 set> CHIME

Management of the warning signal (chime)

Panel for setting the chime that is produced on activating a voice source.

• Attivazione del tono di Chime:

Press keys 2, 3 and 4 then release them to set the chimes for the various different sources:

- 2-Emerg. unit call:** FMD 2001 and FMD 2012 Emergency Stations for broadcasting announcements connected to the "EMERGENCY UNITS" socket.
- 3-Brd. unit call:** Microphone stations of the MBT 1106 or MBT 1112 ranges connected to the "PAGING UNITS" socket.
- 4-Preced. call:** Inputs programmed to activate announcements by means of precedence or VOX contacts.

Reference values:

ON=Chime active

OFF=Chime not active

• Adjustment of the volume of the Chime tone:

Hold down key 1 and use the +/- knob to adjust the volume within the range from 0 to 255; the volume is common to all four inputs and is separate from the volume adjustment assigned to the sources.

• Loading the Chime tone:

The Chime audio file is managed by the dedicated software (see page 83).

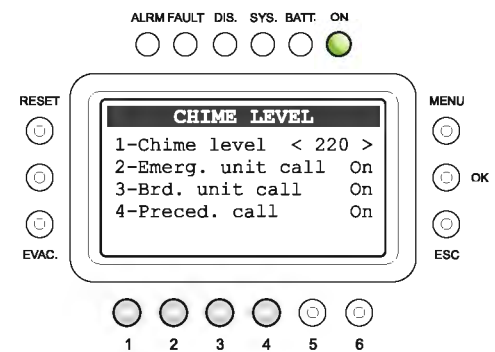
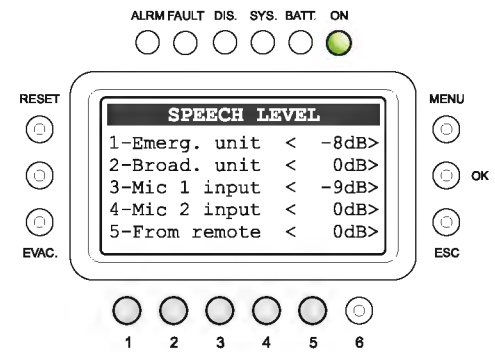
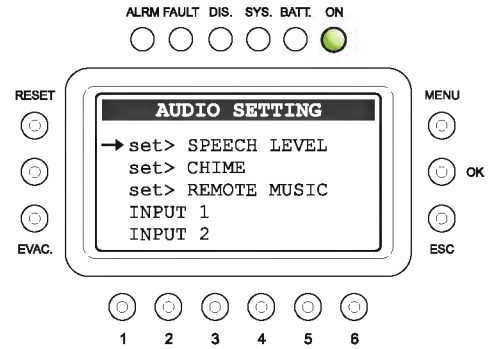

8.3.3 set> REMOTE MUSIC

Managing Music towards other controllers

Panel enabling music to be sent to other controllers connected to the LINK A and B lines to be enabled/disabled. Activation of this function on a single controller within the system is recommended.

Reference values:

ON=Function active

OFF=Function not active

The RESET, ALERT, EVAC, MENU and OK keys are not operational. Press ESC to return to the AUDIO SETTING menu.

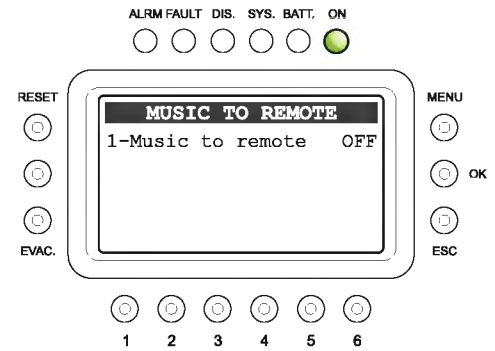

8.3.4 INPUT 1

Management of the source on the IN 1 input

Hold the numerical key associated with the function down and turn the +/- knob to adjust the setting.

- **1-Mode:** Setting of the operating mode of the input for using the voice channel as a PA Source.

Hold key **1** (Mode) down and turn the +/- knob to select the required mode from among the following:

> On:

The input will be connected directly as a voice source and will be operational on the basis of the priority and of the zone list that is selected.

> VOX lev. 1÷7:

This input is set as a voice source with automatic precedence activated by the presence of the incoming audio signal. The precedence is activated when the audio signal exceeds the threshold level that has been set. It is possible to choose from among seven increasing threshold levels. Careful adjustment of the threshold will enable prompt broadcasting of the signal to be achieved, avoiding involuntary activation of precedence by noise induced on the cable.

> Precedence:

The input is enabled for broadcasting as a voice source by closure of a contact connected to the precedence terminals.

- > **Off:** input disabled for the PA announcement function. The source connected continues to be available for selection as a BGM Source.

- **2-Zone call:** Setting the operating mode of the input for using the voice channel as a PA source. Hold down key **2** (Zone call) then turn the +/- knob to select the required mode from among the following options:
 - > **Z. 1 ÷ Z. 216:** To select the specific zone in which you wish to broadcast the calls/music.
 - > **All:** To broadcast the calls/music to all the zones in the system.
 - > **C. 1 ÷ Z. 64:** To select a pre-established group of zones (these configurations can be created using the controller.exe software) in which to broadcast the calls/music.

- **3-Hold on:** To set the release time after an input signal, when the VOX mode is selected. Hold down key **3** (Hold on) then turn the +/- knob to choose a time (between 1 and 99 secs.).

- **4-Priority:** Priority assigned to an input when it is used as a voice source for service announcements. There are 7 priority levels. The input can be muted by another voice source featuring a higher level of priority. Hold down key **4** (Priority) then turn the +/- knob to choose the required level.

- **5-Sensitivity:** Adjustment of sensitivity. Press key **5** (Sensitivity) to choose the required level (between 0, 6, 12 or 18 dB).

- **6-Phantom:** Setting of the Phantom power supply (OFF = not active / ON = active). To change the setting, press key **6** (Phantom), then release it.

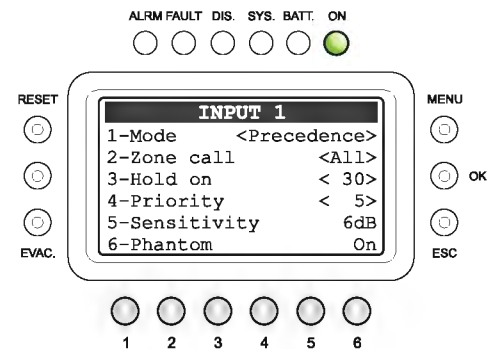

The RESET, ALERT, EVAC, MENU and OK have no functions. Press ESC to return to the AUDIO SETTINGS menu.

8.3.4 INPUT 2

Management of the source on the IN 2 input

Hold the numerical key associated with the function down and turn the +/- knob to adjust the setting.

- **1-Mode:** Setting of the operating mode of the input for using the voice channel as a PA Source.

Hold key **1** (Mode) down and turn the +/- knob to select the required mode from among the following:

> **On:**

The input will be connected directly as a voice source and will be operational on the basis of the priority and of the zone list that is selected.

> **VOX lev. 1÷7:**

This input is set as a voice source with automatic precedence activated by the presence of the incoming audio signal. The precedence is activated when the audio signal exceeds the threshold level that has been set. It is possible to choose from among seven increasing threshold levels. Careful adjustment of the threshold will enable prompt broadcasting of the signal to be achieved, avoiding involuntary activation of precedence by noise induced on the cable.

> **Precedence:**

The input is enabled for broadcasting as a voice source by closure of a contact connected to the precedence terminals.

- > **Off:** input disabled for the PA announcement function. The source connected continues to be available for selection as a BGM Source.

- **2-Zone call:** Setting the operating mode of the input for using the voice channel as a PA source. Hold down key **2** (Zone call) then turn the +/- knob to select the required mode from among the following options:
 - > **Z. 1 ÷ Z. 216:** To select the specific zone in which you wish to broadcast the calls/music.
 - > **All:** To broadcast the calls/music to all the zones in the system.
 - > **C. 1 ÷ Z. 64:** To select a pre-established group of zones (these configurations can be created using the controller.exe software) in which to broadcast the calls/music.
- **3-Hold on:** To set the release time after an input signal, when the VOX mode is selected. Hold down key **3** (Hold on) then turn the +/- knob to choose a time (between 1 and 99 secs.).
- **4-Priority:** Priority assigned to an input when it is used as a voice source for service announcements. There are 7 priority levels. The input can be muted by another voice source featuring a higher level of priority. Hold down key **4** (Priority) then turn the +/- knob to choose the required level.
- **5-Sensitivity:** Adjustment of sensitivity. Press key **5** (Sensitivity) to choose the required level (between 0, 6, 12 or 18 dB).
- **6-Phantom:** Setting of the Phantom power supply (OFF = not active / ON = active). To change the setting, press key **6** (Phantom), then release it.

The RESET, ALERT, EVAC, MENU and OK have no functions. Press ESC to return to the AUDIO SETTINGS menu.

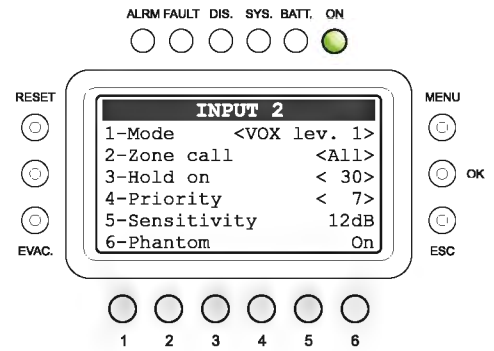

8.4 < INSPECTION > MENU

Panel for selecting options for investigating the status of the system. Only personnel authorised to carry out initial investigation of the causes leading to a *fault* or *emergency* condition may use this panel.

- **report > FAULTS**
- **report > IMPEDANCE**
- **report > CONFIG.**
- **status > CONTROL INP.**
- **test > INDICATORS**
- < OPERATOR >
- < CONFIGURATION >

Press OK to select the required item *or*

- press ESC to return to the MUSIC screen.
- press MENU to return to the HOME page.

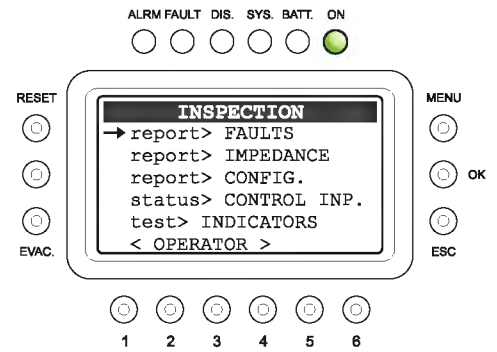

The options of the INSPECTION menu enable the panels for managing the following to be accessed:

8.4.1 FAULTS panel (from the **report> FAULTS** option)

For checking the status of the current or cleared past failures query.

8.4.2 IMP. REAL TIME panel (from the **report> IMPEDANCE** option)

For viewing in real time the line impedance values detected by the system, indicating the percentage of deviation from the value stored at the time of initialising the system.

8.4.3 CTR CONFIGURATION panel (from the **report> CONFIG** option)

To display the system configuration.

8.4.4 CONTROL INPUT STATUS panel (from the **status> CONTROL INPUT** option)

For viewing in real time the status of the input contacts of the VAC 2006 that can activate an Automatic Emergency.

8.4.5 INDICATORS TEST panel (from the **test> INDICATORS** option)

For checking the functionality of the signalling elements connected with the emergency (buzzer loudspeaker, display and LEDs)

< OPERATOR >

Passaggio diretto al menu OPERATOR (*point 8.5, page 102*).

< CONFIGURATION >

Passaggio diretto al menu CONFIGURATION (*point 8.6, page 106*).

8.4.1 FAULTS
For viewing the failed components

Six groups are listed, with a generic indication of the fault condition. The categories of failed parts and generic signalling of their states are shown in the table below.

Press the associated numerical key (1-6) to select the sub-panel and view the details of the failure, as illustrated under points below

or

Press ESC to return to the INSPECTION panel.

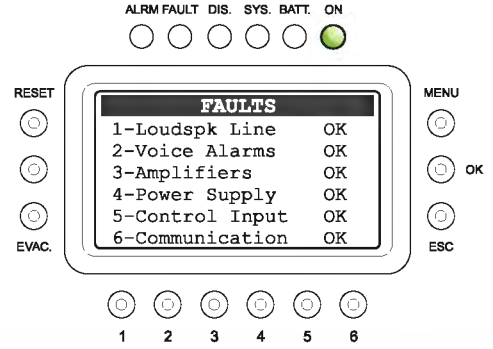

Label	Diagnostic category	See panel		Signalling	Cause
1-Loudspk Line	Loudspeaker lines	LOUDSPK. LINE FAULT	ALL	OK	No faults
2-Voice Alarms	Emergency sources	VOICE ALARMS FAULT			
3-Amplifiers	Power amplifiers Ground fault loudspeaker lines	AMPLIFIER FAULTS			
4-Power Supply	Primary and secondary power supplies Management memory display	POWER SUPPLY FAULTS		FAULT	At least 1 fault detected and on-going
5-Control Input	Local input contacts	CONTROL INPUT FAULT		RES	At least 1 fault cleared and no on-going faults
6-Communication	VAC 2006 internal data communication	COMMUNICATION FAULT			

Tab. 8.4.1.1

8.4.1.1 Automatic resetting of the acoustic signal (beep) following clearing of a failure

If the cause of a failure is cleared before the beep is reset manually (see OPERATOR Menu, point 8.5.3.1, page 105), the VAC 2006 will reset the beep automatically, extinguish the FAULT LED and indicate RES (RESUMED) in the label of the part that had FAILED. The RESOLVED signal will be stored until a MANUAL RESET of the failure signal is carried out from the FAULTS panel via the OPERATOR menu.

8.4.1.2 LOUDSPK. LINE FAULT

Diagnostics of line speaker units

From the FAULTS panel (point 8.4.1), press numerical key **1** and access the panel for viewing the loudspeaker line diagnostics: the diagnostics for each output zone are shown as indicated in the following table.

Press ESC to return to the FAULTS panel.

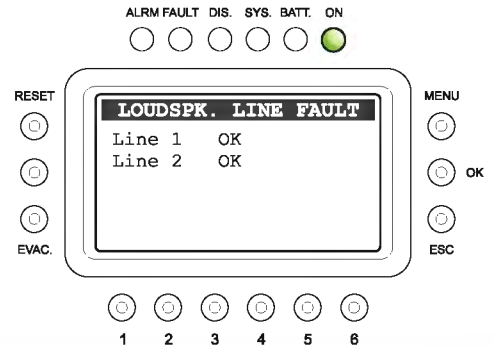

Label	Part being diagnosed		Signalling	Cause	Action required
		ALL	OK	No failure	-
Line 1	Speaker units Zone 1		Short A	Short circuit on the line connected to output A	Eliminate the short circuit and carry out a MANUAL RESET of the FAILURE signal (from the OPERATOR menu)
Line 2	Speaker units Zone 2		Short B	Short circuit on the line connected to output B	
Line 3	Speaker units Zone 3		Short A+B	Short circuit on both lines of the zone (Note ¹)	
Line 4	Speaker units Zone 4		Impedance Hi	Impedance level higher than acquired value detected, beyond the tolerance set during configuration (Note ²)	Check the connections of the speaker units and if necessary repeat the line acquisition procedure (ACQUIRE IMPEDANCE)
Line 5	Speaker units Zone 5		Impedance Low	Impedance level lower than acquired value detected, beyond the tolerance set during configuration (Note ²)	
Line 6	Speaker units Zone 6		Res. imp. Hi	Failure ("Impedance Hi" signal) cleared	Access the Report > FAULTS panel from the OPERATOR menu and carry out a MANUAL RESET of the FAILURE signal
			Res. imp. Low	Failure ("Impedance Low" signal) cleared	

Tab. 8.4.1.2

Note¹:

To eliminate a short circuit between lines A+B and then reset the amplifier on the line, simply press RESET.

Note²:

"Impedance Hi" and "Impedance Low" failures are not reported if the tolerance is set at a higher level than the measured variation of the impedance or if the test is disabled. For details concerning programming, see the SET TOLERANCE panel (point 8.6.2, page 107).

8.4.1.3 VOICE ALARMS FAULT

Diagnosing faults of the Emergency sources

From the FAULT panel (point 8.4.1), press numerical key **2** and access the panel for viewing the diagnostics of the Emergency sources. The diagnostic state of each item monitored is reported, as shown in the following table.

For some items of equipment it may be necessary to access the sub-panel, by pressing the corresponding numbered key.

Press ESC to return to the panel FAULTS.

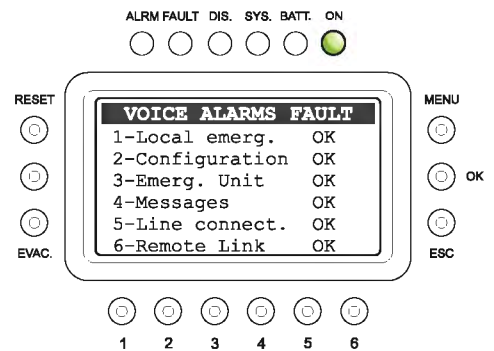

Label	Part being diagnosed	Display	Cause	Action required
All	All	OK	No failure	-
		N.T.	Diagnostics disabled during configuration (see Set> BACKGROUND TEST menu)	-
		Res.	Failure (Fault signal) cleared	Access the Report> FAULTS panel from the OPERATOR menu and carry out a MANUAL RESET of the FAILURE signal.
1-Local emerg.	Hand-held microphone or Emergency Push-button.	Fault	Failure of hand-held microphone or of Emergency Push-button.	<i>Make sure that the microphone has been correctly plugged into the socket on the front panel. If the failure persists, contact the Service Centre.</i>
2-Configuration	SD card	Fault	SD card error or error in reading messages.	Make sure that the SD card has been correctly plugged into its slot on the rear panel of the controller.
3-Emerg. Unit	Emergency microphone stations	Fault	Failure of at least one emergency microphone station.	Make sure that the microphone of the station is correctly plugged in. <i>If the failure persists, contact the Service Centre.</i>
4-Messages	Recorder/player of the emergency EVAC and ALERT message	Fault	Presence of two or more failures.	Make sure that the SD card has been correctly plugged into its slot on the rear panel of the controller.
5-Line connect.	CAT5 connection to: - DPU - VAR - AMP	Fault	Communication error.	Check the connections. <i>If the failure persists, contact the Service Centre.</i>
6-Remote Link	Intercommunication with remote VAC 2006 units	Fault		Press key 6 to access the dedicated "LINK FAULTS" panel. Check the connecting cables between the VAC 2006 units for connection VAC 2006 LINK. <i>If the failure persists, contact the Service Centre.</i>

Tab. 8.4.1.3

8.4.1.4 AMPLIFIER FAULTS

Power amplifier diagnostics and GND fault

From the FAULTS panel (point 8.4.1), press numerical key 3 and access the panel for viewing the power amplifier diagnostics and ground faults of the loudspeaker lines.

The diagnostic state of each item monitored is reported, as shown in the following table (Table D).

Press ESC to return to the panel FAULTS.

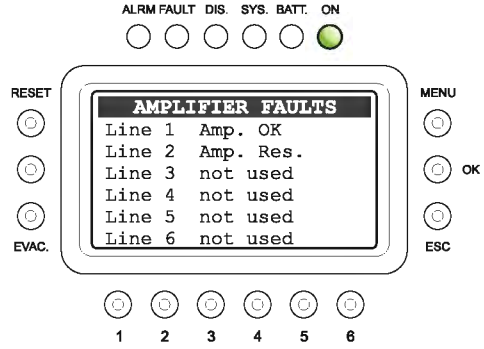

Label	Part being diagnosed	Display	Cause	Action required
All	All	OK	No failure	-
		N.T.	NOT TEST. Diagnostics disabled during configuration (See Set> BACKGROUND TEST menu)	-
		Res.	Failure cleared due to previous Fault signal	Access the report> FAULTS panel from the OPERATOR menu and carry out a MANUAL RESET of the FAILURE signal.
Amplifier n	Amplifiers of the DPU range connected to the controller or MPA 5240/48 amplifiers connected to the router	Amp ok		-
		<u>Input 20kHz</u>	Check that the connection between the controller and the amplifier is sound.	Check that the connections between the controller, the amplifier and the router have been made correctly. <i>If the failure persists, contact the Service Centre.</i>
		<u>Out 20kHz</u>	Make sure that there is an output signal on the line.	Make sure that the amplifier has been connected to the network and switched on. <i>If the failure persists, contact the Service Centre.</i>
		<u>Gnd Fault</u>	Check the insulation between the loudspeaker lines and earth.	Check the connections of the loudspeaker lines. <i>If the failure persists, contact the Service Centre.</i>

Tab. 8.4.1.4

8.4.1.5 POWER SUPPLY FAULTS

Power supply and display memory diagnostics

From the FAULTS panel (point 8.4.1), press numerical key 4 to access the panel for viewing the diagnostics of the primary and secondary power supplies and of the memory for managing the display.

The diagnostic state of each item monitored is reported, as shown in the following table.

Press ESC to return to the FAULTS panel.

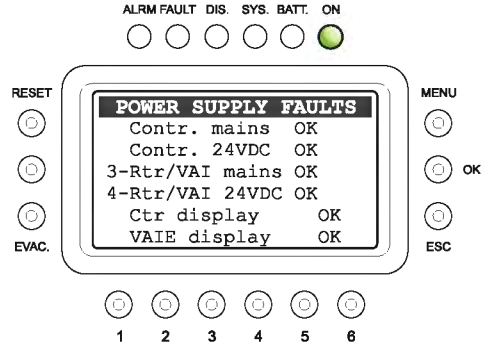

Label	Part being diagnosed		Cause	Action required
All	All	OK	No failures	-
		N.T.	NOT TEST. Diagnostics disabled during configuration (See Menu set> BACKGROUND TEST)	-
		Res.	Failure cleared due to previous failure signal	Access the Report> FAULTS panel from the OPERATOR menu and carry out a MANUAL RESET of the FAILURE signal.
Contr. mains	Primary power supply of the controller @230V _{AC}	Fault	Primary power supply of the controller not detected	Check the 230 VAC power supply, the connecting cable and the mains fuse. <i>If the failure persists, contact the Service Centre.</i>
Contr. 24VDC	Secondary power supply of the controller @24V _{DC}		Secondary power supply of the controller not detected	Check the 24 VDC power supply, the connecting cable and the mains fuse. <i>If the failure persists, contact the Service Centre.</i>
3-Rtr/VAI mains	Primary power supply of the router/VAIE 2250 @230V _{AC}		Primary power supply of the router or VAIE 2250 not detected	Check the 230 VAC power supply, the connecting cable and the mains fuse. <i>If the failure persists, contact the Service Centre.</i>
4-Rtr/VAI 24VDC	Secondary power supply of the router/VAIE2250 @24V _{DC}		Secondary power supply of the router or VAIE 2250 not detected	Check the 24 VDC power supply, the connecting cable and the mains fuse. <i>If the failure persists, contact the Service Centre.</i>
Ctr display	Controller display	Fault	Upset detected on display	Contact the Service Centre.
VAIE display	VAIE 2250 display	Fault	Upset detected on display	Contact the Service Centre.

Tab. 8.4.1.5

8.4.1.6 INPUT ERROR

Diagnostics of the local control inputs

From the FAULTS panel (point 8.4.1), press numerical key **5** to access the panel for viewing the diagnostics of the local control inputs. The diagnostic state of each item monitored is reported, as shown in the following table. Press ESC to return to the panel FAULTS.

INPUT ERROR	
1-Controller	OK
2-Rtr/VAIE	OK

Label	Part being diagnosed	Display	Cause	Action required
No input fault found	Input contacts 1 to 8	Empty list	No failure, or monitoring not enabled for any input contacts	-
Input in fault:		List number of inputs	Break or short circuit in the line connecting the contact	Check integrity of the line connecting the balancing resistors and the activation contact. If the problem persists, disconnect the line connecting the activation contact and connect a 20 kΩ resistor between the +24V service terminals and the control input. If the problem persists, contact Servicing.
Inputs fault resumed:			Failure cleared due to previous failure signal	Access the Report> FAULTS panel from the OPERATOR menu and carry out a MANUAL RESET of the FAILURE signal.
General Input Fault:		Empty list	Failure of the internal communication between the CPU and the inputs controlled stage.	If the problem persists, contact Servicing.
General Fault resumed:			Failure cleared due to previous failure signal	Access the Report> FAULTS panel from the OPERATOR menu and carry out a MANUAL RESET of the FAILURE signal.

Tab. 8.4.1.6

8.4.1.7 COMMUNICATION FAULT

Diagnostics of the internal data communication of VAC 2006

From the FAULTS panel (point 8.4.1), press numerical key **6** and access the panel for viewing the diagnostics of the internal data communication of VAC 2006. The diagnostic state of each item monitored is reported in the following table. Press ESC to return to the panel FAULTS.

COMMUNICATION FAULT	
I2C bus	OK
SPI bus	OK

Label	Data being diagnosed		Display	Cause	Action required
I2C bus	Data communications between the CPU and the keys and front-panel LEDs	All	Fault	Internal communication failure.	Contact the Service Centre.
SPI	Data communication between CPUs.	All	Fault	Internal communication failure.	Contact the Service Centre.

Tab. 8.4.1.7

8.4.2 IMP. REAL TIME | Real-time line impedance

Panel for checking the impedance values measured in real time, and percentage variations from the value stored during start-up, using the "Line impedance acquisition" procedure. The lines being used are listed. You can select a numerical key to access the corresponding panel indicating the impedance measured in Ohms referred to the parallel of lines A and B connected to that line.

LINE 1 IMP REAL TIME		
Zone 1 impedances		
Amp<1>:	416	1%

LINE 2 IMP REAL TIME		
Zone 7:	100	0%
Zone 8:	3361	0%
Zone 9:	17245	0%
Zone 10:	17245	0%
Zone 11:	17245	0%
Zone 12:	17245	0%

If the percentage of variation exceeds the level of tolerance set at the time of configuring the system, a "LOUDSPK LINE FAULT" due to an excessively high or low impedance (Impedance Hi or Impedance Low) will be signalled. Press ESC to return to the INSPECTION panel.

8.4.3 CTR CONFIGURATION
System configuration

Panel showing how the system is configured, on which a list of all the units present in the system is provided, as well as the address of the controller:

- Ctr address** (address of the controller in question): 0 to 5
- System Ctr** (number of controllers in the system): 1 to 6
- Emerg. unit** (number of emergency stations) 1 to 7
- Broad. unit** (number of broadcasting units) 1 to 16
- Used ctr lines** (number of lines used for the controller in use): 0 to 6
- confCtr v.** (version of the system configuration file) 0.n

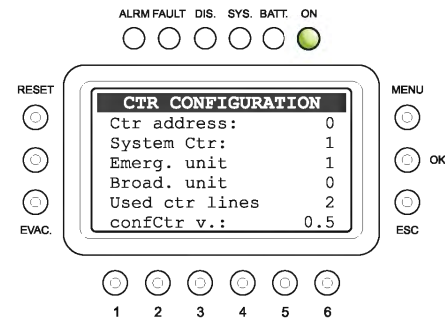

8.4.4 CONTROL INPUTS STATUS
Status of the local input contacts

Panel for viewing the status of the local input contacts (CONTROL INPUTS). A list of the input contacts activated by external peripheral units is provided.

The CONTROL INPUT STATUS panel shows the active inputs, both if no events are associated with them and if an outgoing message event has been associated with them at the time of configuration.

In the event of activation of a programmed local input, the VAC 2006 controller will stop the normal activity associated with the "Idle" status, mute the music being broadcast and inhibit the functions of the PA sources for broadcast announcements, and display the "INPUT EMERGENCY" panel. This will indicate which external input has activated the emergency (point 8.8, page 112).

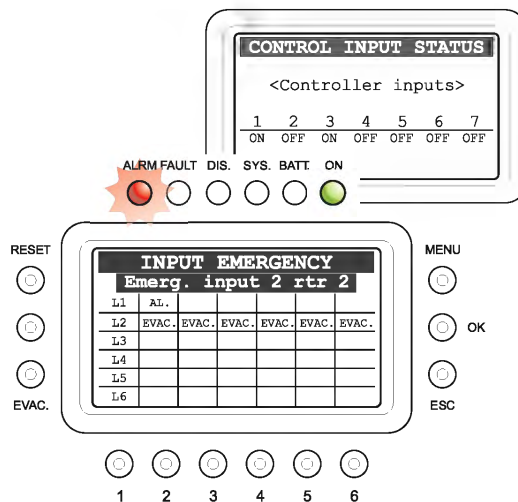

The functionality of the inputs is defined by the firmware controller.exe.

Note: if several input contacts are activated simultaneously, with different programming of the messages in relation to the zones, for each zone output the system will enable the event with the highest priority (see table).

Maximum priority	General reset of messages (RESET)
High priority	Pre-recorded Evacuation message (EVAC)
Low priority	Pre-recorded Alert message (ALERT)
Minimum priority	No event (NONE)

Press ESC to return to the INSPECTION panel.

8.4.5 INDICATORS TEST
Check of the functionality of the visual and audio signal elements

Panel for checking speaker functionality (BEEP), display and operating emergency LED indicators. All LEDs on the front panel (excluding 'ON' LED) and the EMERGENCY key LED are flashing. A horizontal bar running for the whole width of the display is also activated and the warning signal (BEEP) will sound for about three seconds. The functionality of the built-in speaker, all LEDs and all the display pixels are checked. Please contact Support in case of failure. Press ESC to return to the INSPECTION panel.

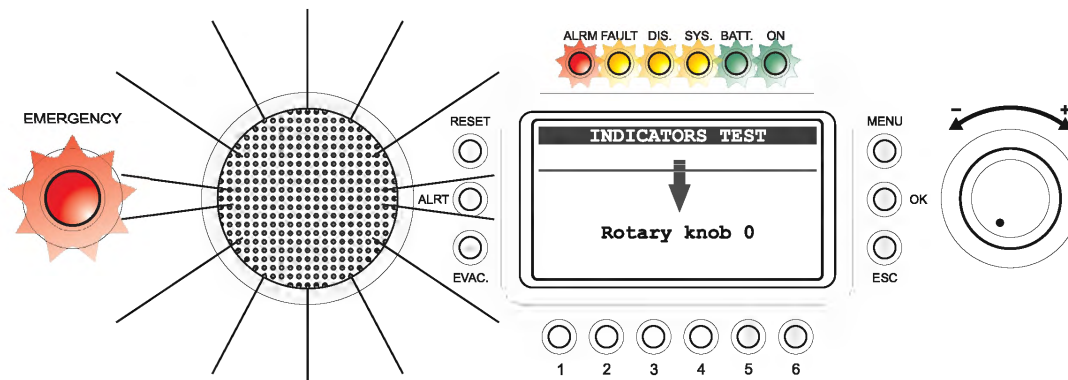



8.5 < OPERATOR > MENU

Panel for selecting options for which the personnel instructed and authorised to manage the system in *emergency, failure* and *disablement* conditions are responsible.

If an access password was enabled during configuration, the following panel will be shown: **OPERATOR ACCESS**.

- Enter the 4-digit password and OK to proceed,
or
- press ESC to return to the HOME page.

The default password is **2222**.

Following access, from the OPERATOR menu, turn the knob to browse through the options listed:

- **set > SPEECH LEVEL**
- **set > BACKGROUND TEST**
- **report> FAULTS**
- *report> IMPEDANCE*
- *report > FAULTS*
- *report> CONFIG.*
- *status> CONTROL INP.*
- *test> INDICATORS*
- **Firmware Version**
- < **INSPECTION >**
- < **CONFIGURATION >**
- **Exit > Logout**

Select the required item by pressing OK, or

- press ESC to return to the MUSIC panel,
- press MENU to return to the HOME page.

The options of the OPERATOR menu enable the following management panels to be accessed:

8.5.1 pannello **SPEECH LEVEL** (da opzione **set > SPEECH LEVEL**)

Adjustment of the level of the voice sources connected to the controller.

8.5.2 **BACKGROUND TEST** panel (via the **set > BACKGROUND TEST** option)

For enabling and disabling monitoring of parts affecting the ability of the system to function in emergency conditions.

8.5.3 **FAULTS** panel (via the **report > FAULTS** option)

Query concerning the status of current and cleared failures as described in the Section on INSPECTION. In addition, this level enables **MANUAL RESETTING OF FAILURE SIGNALS**.

8.5.4 **FIRMWARE VERSION** panel (via the **Firmware Version** option)

This panel shows the version of the firmware installed in the system.

< **INSPECTION >**

For going directly to the INSPECTION menu.

< **CONFIGURATION >**

For going directly to the CONFIGURATION menu.

8.5.5 **Exit > Logout** option

To exit from the service level and return to the basic level, reinstating the access password.

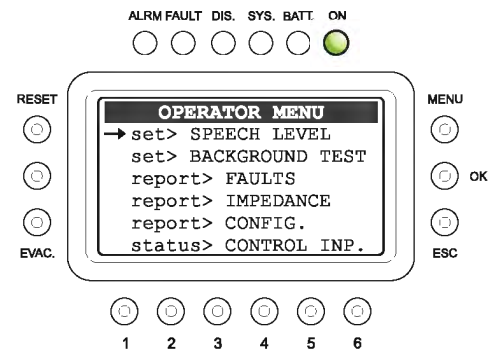

8.5.1 SPEECH LEVEL
Adjustment of the level of the voice sources

Panel for adjusting the levels of the voice sources connected to the VAC 2006 controller. To make the adjustments, press the numerical key corresponding to the required source then turn the +/- knob .

It is possible to select values within a range from 0 to -80dB.

Press ESC to return to the OPERATOR menu.

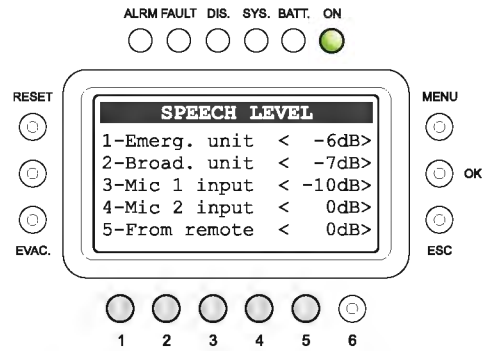

8.5.2 BACKGROUND TEST
Setting the background tests

Panel for enabling and disabling background testing of the critical sources affecting the ability of the system to function in emergency conditions. The categories for choosing the items subjected to diagnostics are listed as shown in the figure opposite.

- The categories for choosing the items subjected to diagnostics are listed as shown in the figure opposite.

- > 2-Voice Alarms see point 8.5.2.1
- > 3-Amplifiers see point 8.5.2.2
- > 4-Power Supply see point 8.5.2.3
- > 5-Control Input see point 8.5.2.4
- > 6-Communication see point 8.5.2.5

or
 press ESC to return to the OPERATOR menu.

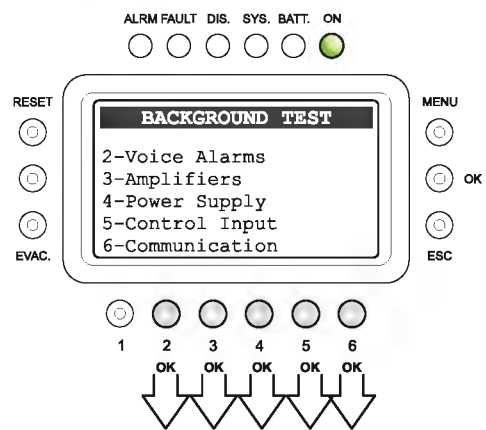

8.5.2.1 VOICE ALARMS
Setting the Test for Emergency Sources

Panel for enabling and disabling the monitoring tests.

- Press the corresponding numerical key to select required item for opening the sub-menu and then to enable or disable the diagnostic test (**on** = test enabled / **off** = test disabled):

- > **1-Local Emerg.** > 1-Microphone
 > 2-Emerg. button
- > **2-Configuration** > 1-SD card
 > 2-Msg table
- > **3-Emerg. Unit** > 1-Ctr unit <1>
- > **4-Messages** > 1-Evac message
 > 2-Alert message
- > **5-Line connect.** > 1÷6-Line *n* connect.
- > **6-Remote Link:** > 1-Remote link A
 > 2-Remote link B
 > 3-Remote ctr

Note: The display will show the programming that has been set.
 Press ESC to return to the BACKGROUND TEST panel.

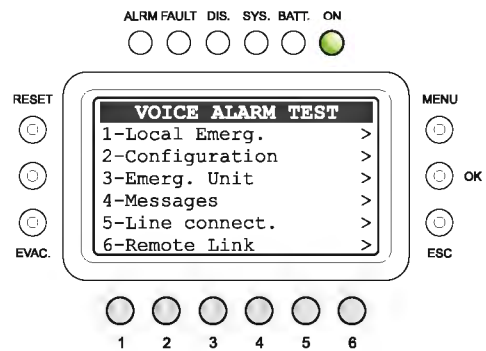

8.5.2.2 AMPLIFIERS

Setting the tests for the Amplifiers

Panel for enabling and disabling the *voice* and *music* amplifier monitoring tests.

- Press the appropriate numerical key to enable or disable the diagnostic test (**on** = test enabled / **off** = test disabled):

- > 1-Ampli Line 1 (on = test enabled / off = test disabled)
- > 2-Ampli Line 2 (on = test enabled / off = test disabled)

Note: The display will show the programming that has been set.

Press ESC to return to the BACKGROUND TEST panel.

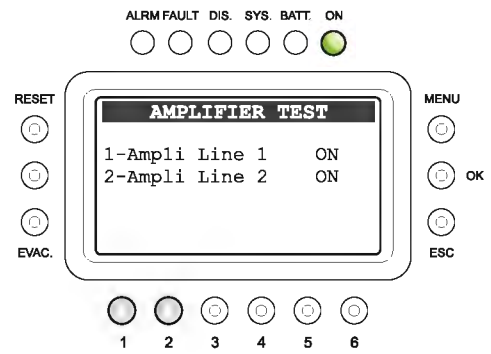

8.5.2.3 POWER SUPPLY

Setting the test for the Power Supplies

Panel for enabling and disabling the monitoring tests applied to the 230 VAC primary power supply and to the 24 VDC secondary power supply.

- Press the appropriate numerical key to enable or disable the diagnostic test:

- > 1-Mains P.S. (on = test enabled / off = test disabled)
- > 2-24Vdc P.S. (on = test enabled / off = test disabled)
- > 4-Display (on = test enabled / off = test disabled)

Note: The display will show the programming that has been set.

Press ESC to return to the BACKGROUND TEST panel.

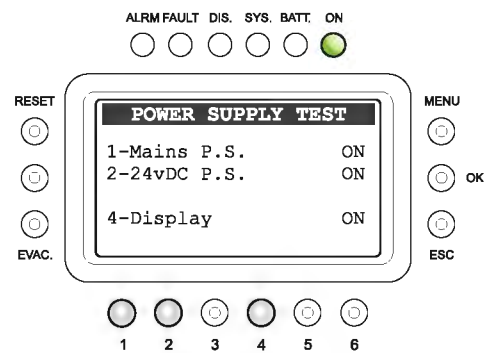

8.5.2.4 CONTROL INPUT

Enabling of testing of controlled inputs

Panel for enabling and disabling the monitoring tests applied to the controlled inputs.

- Press the appropriate numerical key to enable or disable the diagnostic test:

- > 1-Controller IN (on = test enabled / off = test disabled)
- > 2-Rtr/PA IN (on = test enabled / off = test disabled)

Note: The display will show the programming that has been set.

Press ESC to return to the BACKGROUND TEST panel.

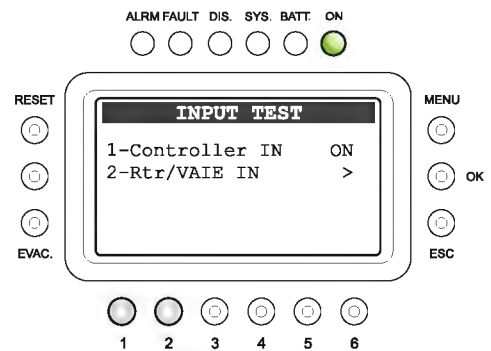

8.5.2.5 COMMUNICATION

Setting the test for internal data communication

Panel for enabling and disabling testing applied to communication data between internal sections of VAC 2006.

- Press the appropriate numerical key to enable or disable the diagnostic test:

- > 1-Communication (on = test enabled / off = test disabled)

Note: The display will show the programming that has been set.

Press ESC to return to the BACKGROUND TEST panel.

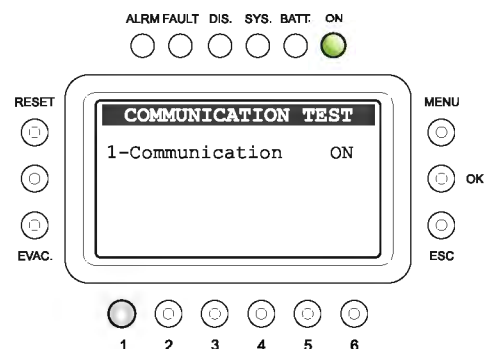

8.5.3 FAULTS

Viewing of Failures (from the OPERATOR menu)

The OPERATOR menu provides access to the "FAULTS" panel, as illustrated in the "FAULTS" section of the <INSPECTION> menu. The additional function enabled on accessing the "Report> FAULTS" panel from the OPERATOR level is "Manual Resetting of a Failure Signal".

8.5.3.1 Manual Resetting of a Failure Signal (RES)

Manual Resetting is necessary in the following cases:

- To cancelled a stored **RES** (RESUMED) signal following detection and subsequent clearing of a failure, for all the other items being monitored.
- To reset the buzzer.

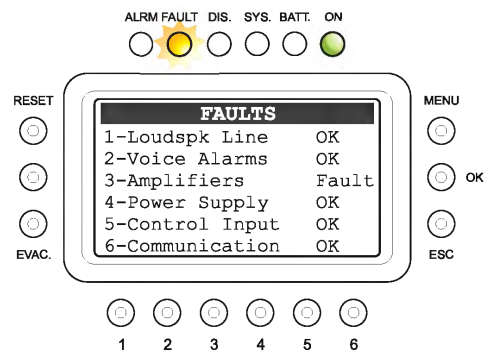

To RESET the FAULT signalling manually, from the general FAULT display panel

- Press the **RESET** key

Upon completion of the procedure, press the ESC key repeatedly to return to the OPERATOR menu.

8.5.4 FIRMWARE VERSION

For viewing the Firmware version

Panel for viewing the version of the firmware installed in the system. The firmware of the following three sections is indicated:

- > **Units software**
Main software installed on the CPU for managing the units.
- > **Zones software**
Main software installed on the CPU for managing the zones.
- > **Matrix firmware**
Firmware for managing the audio signals.

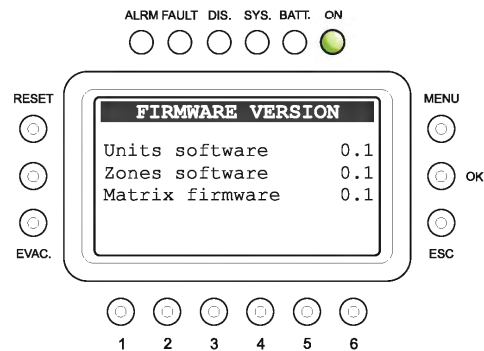

8.5.5 Exit > Logout

Exiting from a System Level

Upon completing the various activities, before returning to the Basic Level of the Music Menu, it is advisable to log out of the System Level of the current menu, in order to reinstate the password required for accessing the system again in future, thus preventing unauthorised personnel from accessing the advanced functions of the system.

From the options list of the OPERATOR MENU:

- turn the +/- knob to select the following option:

Exit> Logout

- press the OK key

The system will return to the Basic Level, showing the MUSIC Menu panel. The prompt requiring the access password to be entered will also be reinstated for any other levels that had been reached.

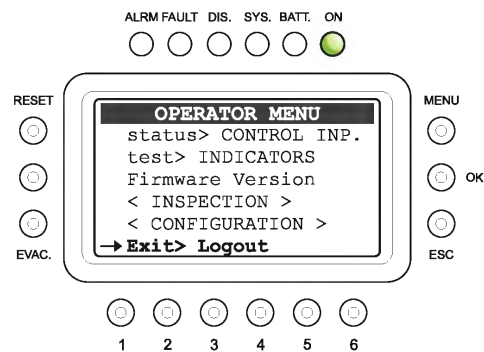



8.6 < CONFIGURATION > MENU

Panel for selecting options pertaining to personnel specifically trained and authorised to use the advanced system functions and to modify the configuration parameters for starting and maintaining the system.

A password for accessing these functions may be added.

If an access password has been enabled, at the time of configuration the **CONFIGURATION ACCESS** panel will be displayed:

- enter the four-digit password then press OK to proceed, or
- press ESC to return to the MAIN page.

The default password is **3333**.

Once the CONFIGURATION Menu is accessed, all the options illustrated earlier in the “AUDIO SETTING”, “INSPECTION” and “CONFIGURATION” menus will be shown, as well as the following new options specific to the CONFIGURATION menu.

Turn the knob to browse through the options listed:

- **acquire > IMPEDANCE**
- **set > IMP. TOLERANCE**
- **set > 20KHZ LEVELS**
- **set > ALARM LEVEL**
- *set > SPEECH LEVEL*
- **set> AMP SET TIME**
- *set > BACKGROUND TEST*
- *set > CHIME*
- *report > FAULTS*
- *report > IMPEDANCE*
- *status > CONTROL INP.*
- *test > INDICATORS*

INPUT 1

INPUT 2

Firmware Version

Password

Beep operation

< **SERVICE** >

- *Exit > Logout*

- Press OK to select the required item, or
- press ESC to return to the MUSIC panel.
 - press MENU to return to the MAIN page.

The characteristics of the specific panels of the **CONFIGURATION** Menu are illustrated below. For the other available options, refer to the appropriate sections above.

At the end of the setup, log out by selecting “Exit> Logout” as described in point 8.5.5, page 105.

The options of the **CONFIGURATION** Menu enable the following management panels to be accessed:

8.6.1 ACQUIRE IMPEDANCE panel (via the **acquire > IMPEDANCE** option)

For acquiring and storing the impedance values of the speaker unit lines, which is necessary for system initialisation and diagnostics.

8.6.2 SET TOLERANCE panel (via the **set > IMP. TOLERANCE** option)

For setting the tolerance applicable to the line impedance. When the diagnostic system detects impedance that is out of tolerance, a “Fault Warning Condition” is activated.

8.6.3 20KHZ LEVEL SETTINGS panel (via the **set > 20KHZ LEVELS** option)

Setting the levels of the 20 kHz test signal on the various different audio channels.

8.6.4 ALARM LEVEL panel (via the **set > ALARM LEVEL** option)

Panel for adjusting the output volume of the Emergency sources: Emergency Microphones and Alarm Messages.

8.6.5 AMPLIFIER TEST TIME panel (via the **set > AMP SET TIME** option)

Setting the interval between one PMD amplifier test and the next.

8.6.6 pannello PASSWORD panel (via the **Password** option)

Panel for enabling, disabling and customising the password for accessing the system service levels.

8.6.7 BEEP OPERATION panel (via the **Beep operation** option)

Panel for enabling, disabling and customising the system beep.

< **SERVICE** > Connection to the SERVICE menu for technical personnel having the necessary password. It is used to change the operating parameters of the VAC 2006 system, up-dating the firmware and servicing it.

Note: *The settings of the Service Menu are not covered in this Manual.*

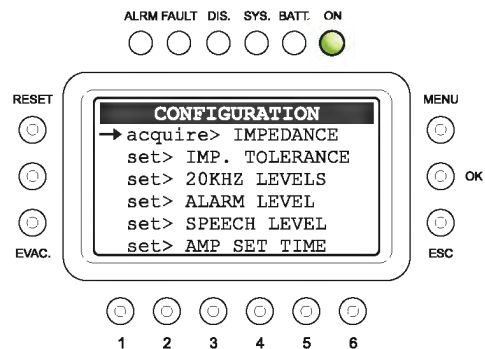
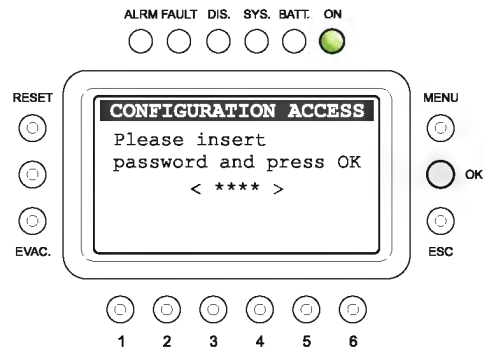

8.6.1 ACQUIRE IMPEDANCE

Line impedance acquisition

Panel for acquiring and storing the impedance levels of the speaker unit lines. This information is necessary for system initialisation and diagnostics.

8.6.1.1 Loudspeaker line impedance acquisition

Foreword

Before acquiring the impedance values, make sure that the following steps have been completed:

- Preliminary check of the impedance of the lines using a suitable instrument (IMPEDANCE-METER) and of the loading conditions.
- Connection of the speaker unit lines as indicated in the CONNECTIONS Section.

After selecting "Acquire> IMPEDANCE" from the CONFIGURATION menu, the "ACQUIRE IMPEDANCE" panel will show the impedance values stored at the time of the previous acquisition:

- press the OK key

The new impedance values acquired will be stored automatically in the system and shown on the labels of each zone. They are in Ohms and refer to both lines, A and B, connected to the output of each zone. The impedance values residing in the memory will be compared by the monitoring system with the values measured subsequently during the diagnostics routine.

Note: To measure the impedance of the speaker unit lines, the monitoring system provided in the VAC 2006 uses an inaudible 20 kHz tone. Due to the inductance of the loudspeaker coils, the impedance at 20 kHz may be considerably different from that measured with an impedance meter, which usually uses a 1 kHz measuring tone. The value acquired by the VAC 2006 is therefore usually indicative only as a comparative value for diagnostic purposes. For this reason, when calculating the power absorbed by the speaker unit lines for the purpose of sizing the system it is recommended to use the value measured with an impedance meter.

* The amplifiers of the DPU range use a tone that has a frequency of 30 Hz.

Press ESC to return to the CONFIGURATION menu.

Upon completing the procedure, carry out a MANUAL RESET of the FAILURE SIGNALLING, as described under point 8.5.3.1, page 105.

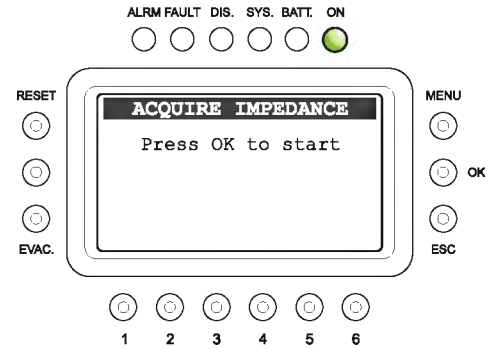

8.6.2 SET TOLERANCE

Setting the line tolerance

If the diagnostic system detects a difference between the impedance measured in real time and the value stored in the system greater than the tolerance that was set: an "Impedance Low" or "Impedance Hi" "Fault Warning Condition" will be activated. For details about signalling of failures, see the "LOUDSPK. LINE FAULT" panel (point 8.4.1, page 96).

8.6.2.1 Setting the tolerance for measuring the lines

Foreword: The measurement tolerance must be set after completing acquisition of the line impedance (see point 8.6.1).

The default value is 30%.

After selecting the "Set>IMP.TOLERANCE" option from the CONFIGURATION menu, the "SET TOLERANCE" panel will show the current tolerance settings for each output zone.

- press the numerical key corresponding to the line.
- Hold the numerical key corresponding to the zone (1-6) down, turning the +/- knob to choose the required value.

>Valori da 10% a 100%: tolerance above or below the stored value.

>Test Disabled: Impedance check disabled. Testing for short circuits and GND faults will in any case be carried out.

It is also possible to disable the impedance test by setting a tolerance of 0% (Not Tested).

Press ESC to return to the CONFIGURATION menu.

Upon completion of the procedure, if appropriate carry out a MANUAL RESET OF THE FAILURE SIGNALLING as described under point 8.5.3.1, page 105.

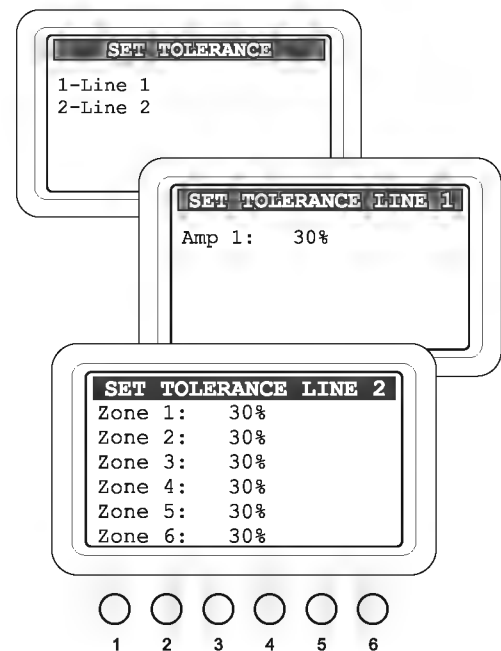

8.6.3 20KHZ LEVEL SETTINGS
Setting the levels of the 20kHz signals

Panel for setting the levels of the 20 kHz test signal on the various different audio channels of the VAC 2006 controller.

> 1-Master level

Master level of the 20 kHz test signal.

- Press key 1 then turn the +/- knob.

> 2-Link music lev.

Output levels of the 20 kHz *music* output signal sent towards the other controllers connected to the system.

- > 1-Link A level > Press key 1 then turn the +/- knob.
- > 2-Link B level > Press key 2 then turn the +/- knob.

> 3-Link speech lev.

Output levels of the 20 kHz *speech* output signal sent towards the other controllers connected to the system.

- > 1-Link A level > Press key 1 then turn the +/- knob.
- > 2-Link B level > Press key 2 then turn the +/- knob.

> 4-Line music lev.

Music channel test levels.

- > 1-Line 1 level > Press key 1 then turn the +/- knob.
- > 2-Line 2 level > Press key 2 then turn the +/- knob.
- > 3-Line 3 level > Press key 3 then turn the +/- knob.
- > 4-Line 4 level > Press key 4 then turn the +/- knob.
- > 5-Line 5 level > Press key 5 then turn the +/- knob.
- > 6-Line 6 level > Press key 6 then turn the +/- knob.

> 5-Line speech lev.

Voice channel test levels.

- > 1-Line 1 level > Press key 1 then turn the +/- knob.
- > 2-Line 2 level > Press key 2 then turn the +/- knob.
- > 3-Line 3 level > Press key 3 then turn the +/- knob.
- > 4-Line 4 level > Press key 4 then turn the +/- knob.
- > 5-Line 5 level > Press key 5 then turn the +/- knob.
- > 6-Line 6 level > Press key 6 then turn the +/- knob.

N.B.: The display shows the status of the factory-set programming.

Press ESC to return to 20KHZ LEVEL SETTINGS panel.

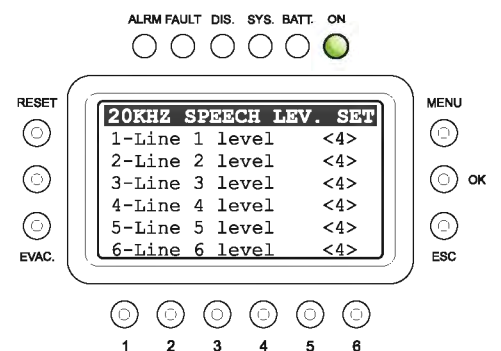
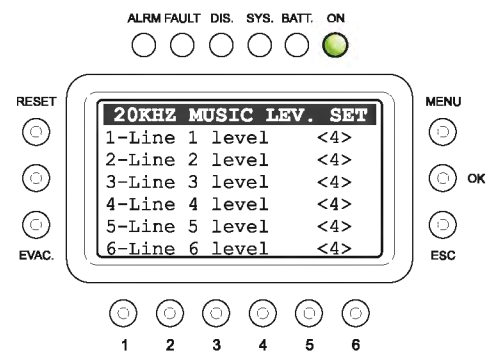
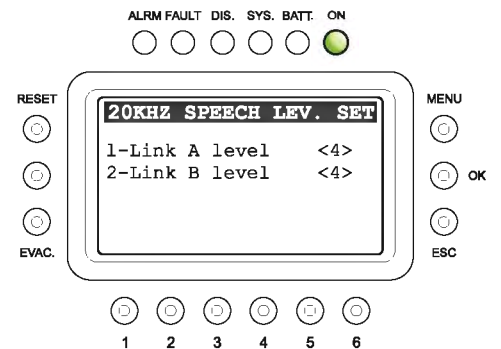
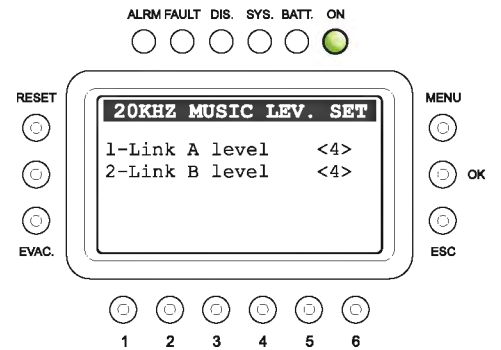
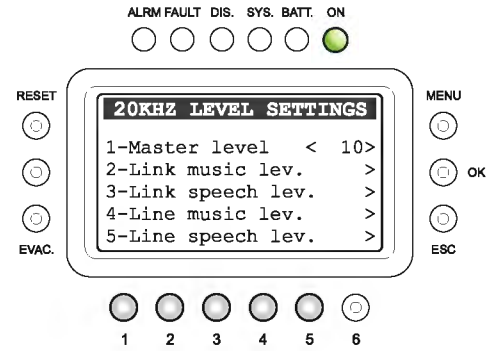

8.6.4 ALARM LEVEL

Adjustment of the volume of emergency sources

Panel for adjusting the output volume of emergency sources for the purpose of calibrating the system.

To adjust the volume of the required source:

- hold the corresponding numbered key (1 - 5) down.
- and
- use the +/- knob to adjust the volume

Note: The volume set will be the same for all the output zones.

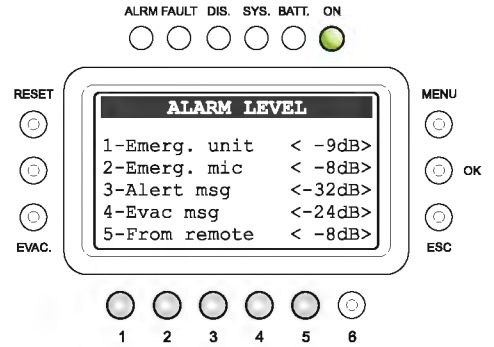

Upon completion, press ESC to return to the CONFIGURATION menu.

1-Output volumes of the FMD emergency microphone stations connected to their local VAC 2006 unit: the adjustment range for the EMERGENCY UNITS is between -80 dB and 0 dB.

2-Output volume of hand-held emergency microphones: the adjustment range for FIRE MICROPHONES is between -80 dB and 0 dB. *It is suggested that in most cases a volume of +16 dB should not be exceeded.*

3-Output volume of pre-recorded ALERT messages: the adjustment range for ALERT MESSAGES is between -80 dB and 0 dB.

4-Output volume of pre-recorded EVACUATION messages: The adjustment range for EVAC MESSAGES is between -80 dB e 0 dB.

5-Volume of emergency signals from VAC 2006 remote controllers: the adjustment range for VAC 2006 LINK is between -80 dB e 0 dB.

8.6.5 AMPLIFIER TEST TIME

Setting the interval between test signals for testing amplifiers of the DPU range

• Hold the corresponding numerical key (1 to 3) down and use the +/- knob to adjust the setting:

- 1-Line Line (1 to 6)
- 2-Amp Amplifier (1 to 16 / ALL)
- 3-Time Length of test (5s to 18h / no test)

Upon completion, press ESC to return to the CONFIGURATION menu.

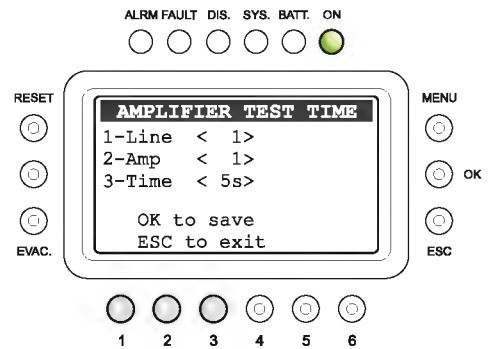

8.6.6 PASSWORD

Setting the password

Panel for enabling, disabling and customising the password for accessing the system service levels.

- Use the +/- knob to position the cursor on each digit of the password to be changed
- Use the numerical keys (1-6) to enter the new password
- Press OK to enable or disable the password as set.

Note: *The display will show the new password programming that has been set.*

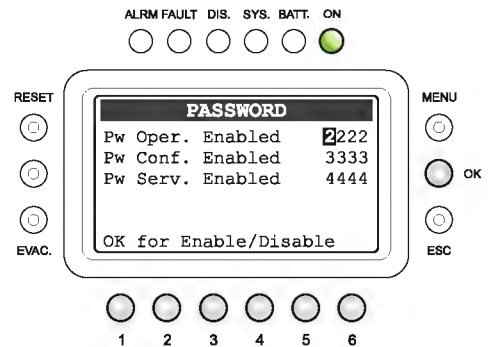

8.6.7 BEEP OPERATION

Management of the system "beep"

Panel for enabling and disabling the system "beep".

- Use key 1 to enable or disable emission of the acoustic signal.

Nota: *The display shows the status of the set programming.*

Upon completion, press ESC to return to the CONFIGURATION menu.

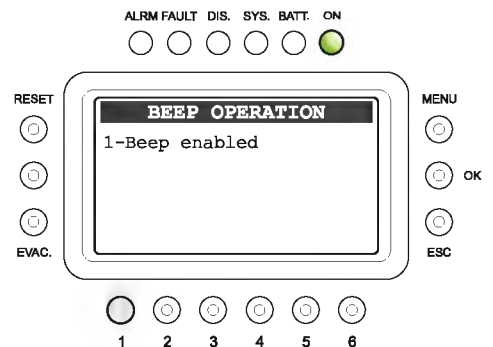



8.7 MANUAL EMERGENCY - < EMERGENCY > Menu

Following is a description of the procedure for managing emergencies manually by an authorised operator.

8.7.1 General information

The manual emergency mode is accessible at all times. Manual emergencies have priority over any pre-recorded messages being broadcast and that were activated by an external peripheral unit connected to the “control Inputs” and over any emergency stations able to broadcast messages via the 6 output lines of the controller being used.

8.7.2 Manual management of emergencies

As explained below, thanks to its dual-channel operation, the VAC 2006 controller enables structured management of alarm messages, of muting of the messages and of selection of the zones. Following is a list of operations providing a brief introduction to manual emergencies.

A) SENDING OF AN EMERGENCY MESSAGE FROM A CONTROLLER

- Press the **EMERGENCY** key once. The key will light up steadily. Activation of the emergency mode will also be shown on the routers, stations and any other controllers connected to the controller.
- Send a voice message (using the hand-held microphone) or an alerting message (**ALERT** key) or evacuation message (**EVAC** key) to all zones. The display will show the type of message being broadcast.

N.B.: Messages sent using a hand-held microphone have absolute priority over pre-recorded evacuation and alert messages.

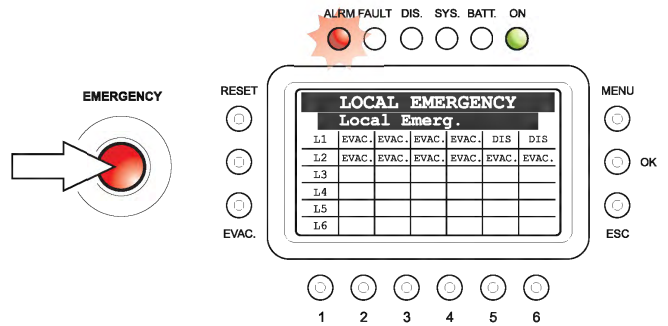

To end live emergency messages, alert messages and/or evacuation messages, press the **EMERGENCY** key again.

B) SENDING AN EMERGENCY SIGNAL FROM REMOTE STATIONS OF THE FMD RANGE

- Lift the safety lid on the station and press the **EMERGENCY** push-button once. It will light up steadily. Activation of the emergency mode by the station will also be shown on the routers and on the controller(s) connected to the station on their displays and by a flashing key.
- Select the zones to which the message should be sent.
- Speak into the microphone, holding the PTT (Push-to-Talk) key down until the end of the message.

N.B.: The PTT key has priority over any pre-recorded messages being broadcast.

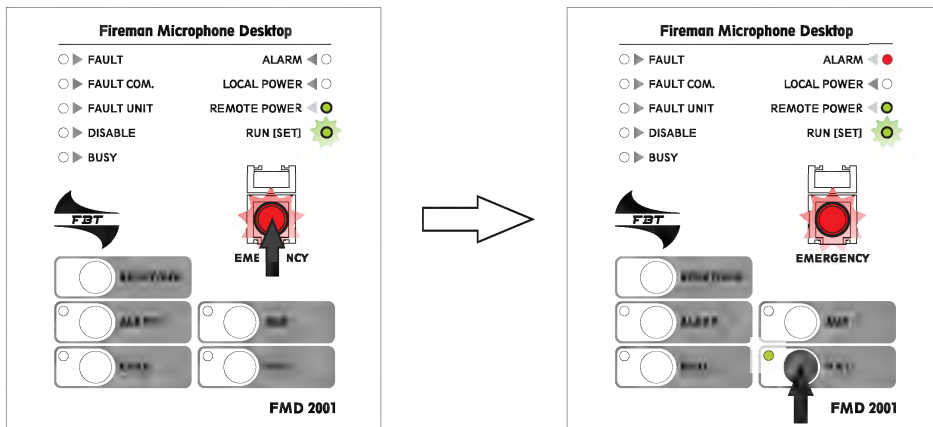

To end live emergency messages, release the PTT key and press the **EMERGENCY** push-button again. Make sure that you close the lid again.

• Sending pre-recorded alert and/or evacuation messages

- Select the zones to which the message should be sent.
- Press the **ALERT** (alert) key or the **EVAC** (evacuation) key to send the pre-recorded message to the zones that have been selected.

To end live emergency messages, release the PTT key, then press the **EMERGENCY** push-button again. Make sure that you close the lid again.

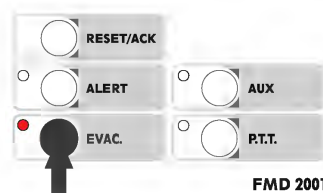

C) EXITING THE SYSTEM FROM MANUAL MANAGEMENT OF THE EMERGENCY

Upon completion of the Manual Emergency management procedure, press the red **EMERGENCY** key, which will extinguish, and:

- If no alarms from external peripheral units connected to the input contacts (Control Inputs) have been activated, then the system will automatically revert to the "Idle" status, displaying the <MUSIC> menu. The ALARM LED will remain OFF to indicate that the VOICE ALARM condition is not active.
- If any alarms from external peripheral units connected to the input contacts (Control Inputs) have been activated, then the system will revert to the Automatic Emergency mode, displaying the INPUT ALARM STATUS menu. Broadcasting of the emergency messages will resume as programmed for the inputs that have been activated, and the ALARM LED will light up, if appropriate, to indicate activation of a VOICE ALARM.

8.8 AUTOMATIC EMERGENCY - Alarm Condition activated from an external peripheral unit

Following is a description of the operating mode of the system in the event of an Automatic Emergency initiated by an external peripheral unit activating the input contacts programmed to enable a "Voice Alarm Condition".

8.8.1 Activation of an Automatic Emergency

In the event of activation of a programmed local input, the VAC 2006 controller will stop the normal activity associated with the "Idle" status, mute the music being broadcast and inhibit the functions of the PA sources for broadcast announcements, and display the "INPUT EMERGENCY" panel. This will indicate which external input has activated the emergency.

If the contact has been programmed to send at least one emergency message to at least one output zone, the system will initiate the Automatic Emergency by enabling a "Voice Alarm Condition" and causing the ALARM LED to light up. The INPUT EMERGENCY panel will show the type of out-going pre-recorded message on each line.

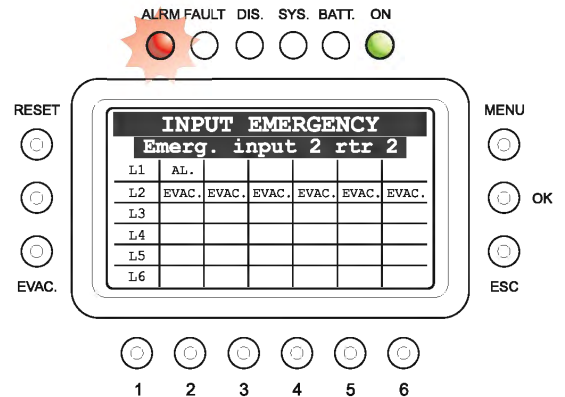

Viewing the operational status

ALARM LED: This LED lights up to indicate that a VOICE ALARM is active when a live microphone announcement or a pre-recorded message are being sent out to at least one zone.

Line status bar:

- **Empty label:** zone without any current message.
- **RESET:** zone mute due to general reset contact.
- **EVAC:** zone with EVACUATION message being broadcast.
- **ALERT:** zone with ALERT message being broadcast.
- **DIS:** zone in which alarms are disabled (see point 8.6.4).
- **FAIL:** zone with failure condition on the speaker line. Label shown even if the type or failure does not prejudice the outgoing signal. When operating on a single channel due to an amplifier failure, this indicates that the zone is unable to broadcast the planned signal.

8.8.2 Operation of the system during Automatic Emergency

As long as the input contacts are active, the MUSIC panel will remain inactive. It will, however, be possible to navigate among the various menus to access the advanced functions of the system and to investigate or change the settings.

- A current "Voice Alarm Condition" due to an Automatic Emergency may be altered by an authorised operator entering the system to activate the manual controls for managing the emergency, in order to RESET the messages, change the current messages or send live announcements using the microphone provided for this purpose.

For details about management of a Manual Emergency, consult the MANUAL EMERGENCY, point 8.7, page 110.

8.8.3 Exiting from an Automatic Emergency

- De-activate the contact that had activated the emergency
or
- Press the EMERGENCY push-button. At the same time, hold the RESET key down for at least 2 seconds, then release it.

To inform the operator that the alarm was activated via external contacts, the controller keeps the notice of the emergency flashing on the display.

The system will return to a "Quiescent Condition" showing the MUSIC panel.

9. FAULT WARNING CONDITION

The VAC 2006 system has a diagnostic routine that monitors constantly availability of the emergency sources and the soundness of the critical path of the signals providing the functions in emergency conditions.

9.1 SYSTEM OPERATION AND SIGNALLING IN GENERIC CONDITIONS

9.1.1 System signalling due to an existing "Fault Warning Condition"

If, with the system in its normal "Quiescent Condition", the monitoring system detects a cause of a failure, it promptly activates signalling of a "Fault Warning Condition", as follows:

- the FAULT LED (visual signal) will light up.
- a BEEP (acoustic signal) will be heard via the monitoring loudspeaker.
- activation of any local output contacts (CONTROL OUTPUTS) that may have been programmed (remote signalling).
- the failure condition (FAULT) will be indicated in the status label on the Report FAULT panel.

9.1.2 System signalling following cleaning of "Fault Warning Condition" (RES)

If the cause of the failure is cleared automatically, without any action on the part of the operator, the system will return automatically to its "Quiescent Condition", resetting all the signals described above and storing the last failure that occurred as follows:

- The word RES will be shown on the status label of the Report FAULT panel indicating that the failure has been cleared.

9.1.3 Resetting the signal following clearing of a failure (FAULT RESET)

To reset a signal referred to a failure that has been cleared and stored:

- From the OPERATOR menu, go to the FAULT panel (point 8.5.3, page 105)
- Carry out a MANUAL RESET of the failure signal as indicated under point 8.5.3.1, page 105.

Note: In the event of failure of a loudspeaker line due to a short circuit, once the line is repaired it is necessary to carry out a MANUAL RESET of the failure from the OPERATOR menu, in order to re-activate the audio signal on the output of the line concerned.

9.1.4 Recommended procedure during a Fault Warning condition

The procedure to be followed during a Fault Warning condition is the following:

- From the INSPECTION menu, go to the FAULT panel (point 8.4.1, page 95)
- Check the category of the FAULT diagnosed and go to the appropriate sub-panel.
- Check the cause of the failure and, if possible, restore correct operation following the instructions contained in the table referred to the sub-panel (see points from 8.4.1.2 to 8.4.1.7).

If upset is successfully cleared, termination of the Fault Warning condition will be signalled as follows:

- The FAULT LED will extinguish.
- The output contact involved, if any, will be de-activated.
- The word RES will appear in the status label of the Report FAULT panel to show that the failure has been cleared.

Upon completion of the procedure, it is advisable to reset the signal for the failure that has been cleared, as indicated under point 9.1.3.

9.2 SYSTEM OPERATION AND SIGNALLING IN THE EVENT OF A SPEAKER LINE FAILURE

A failure of the speaker line may be due to various different causes. The associated signalling and the activities required are described under point 8.4.1.2 *LOUDSPK. LINE FAULT panel*. If the problem is due to a variation in the impedance, the VAC 2006 will continue to broadcast the audio signal output from the zone. If it is due to a short circuit on the line, the system will disconnect the failed line and broadcast the audio signal on the other line serving the same zone.

TECHNICAL SPECIFICATIONS	VAC 2006
Display	3", backlit, 128x64 dots
Inputs	
USB-EXT.	Powered USB input on the front panel - Type A socket
Emergency microphone • Sensitivity / Impedance • Frequency response / S/N ratio	Balanced XLR-F on the front panel Signal level 20 mV / 10 kΩ 60 ÷ 20.000 Hz / 72 dB
IN.1 Socket (MIC.) • Sensitivity / Impedance • Frequency response / S/N ratio	Programmable for the following modes: ON / OFF / Precedence / VOX with A.P.T. Balanced XLR-F (with possibility of activating 24 V phantom power supply) Signal level Min. 3 mV - Max 100 mV / 1,8 kΩ 240 ÷ 20.000 Hz / 63 dB
IN.2 Socket (MIC.) • Sensitivity / Impedance • Frequency response / S/N ratio Socket (LINE) • Sensitivity / Impedance • Frequency response / S/N ratio	Programmable for following modes: ON/ OFF / Precedence / VOX with A.P.T. Balanced XLR-F (with possibility of activating 24 V phantom power supply) Signal level Min. 3 mV - Max 100 mV / 1,8 kΩ 240 ÷ 20.000 Hz / 63 dB Balanced with terminals(HOT-COM-GND) Max signal level 1800 mV / 31 kΩ 60 ÷ 20.000 Hz / 84 dB
AUX • Sensitivity / Impedance • Frequency response / S/N ratio	RCA stereo socket for source of sound (BGM) – Conversion to mono Max signal level 1800 mV / 31 kΩ 60 ÷ 20.000 Hz / 84 dB
Paging units • Sensitivity / Impedance • Frequency response / S/N ratio	2 RJ45 for calling (PA) units of the MBT 1106 / MBT 1112 range. Max signal level 1400 mV / 85 kΩ 60 ÷ 20.000 Hz / 83 dB
EMERGENCY UNITS	RJ45 for connection to a dedicated emergency microphone station.
Outputs	
SLAVE LINK OUTPUT • Output level / Impedance	RJ45 for connection to an VAR 2006 / DPU / VAIE 2250 unit Max 2000 mV / 400 Ω
VAC 2006 LINK • Output level / Impedance • Sensitivity / Input impedance	RJ45 for connection to a VAC 2006 unit Max 2000 mV / 400 Ω 2000 mV / 50 kΩ
Emergency controls • CONTROL INPUTS inputs • CONTROL OUTPUTS outputs	Programmable as Normally Activated or Normally De-activated. 7 inputs with diagnostics. 3 relays for signalling emergency conditions and failures, NO-NC-Changeover terminals.
Precedence IN 1 - IN 2	Precedence input with terminals with common +12 Vdc.
LAN	Presa LAN Rj45 per collegamento TCP/IP a web server.
Overall	
Mains power supply @230V _{Ac} Consumption @230V _{Ac}	230 Vca 50/60 Hz ±10% 10 W
External power supply @24V _{Dc} Consumption @24V _{Dc}	24 Vcc (min 22Vcc ÷ max 28Vcc) 0,3 A
Environmental operating conditions	Temperature: +5°C to +40°C / Relative humidity: 25% to 75% non-condensing
Mounting	Direct to rack 19" (2U).
Size of unit (L x H x D) Size of package (L x H x D)	482 x 88 x 220 mm 522 x 155 x 292 mm
Net weight Gross weight	4,5 kg 5,5 kg

TECHNICAL SPECIFICATIONS	VAR 2006
Mains power supply @230V _{Ac} Consumption @230V _{Ac}	230 Vca 50/60 Hz ±10% 12 W
External power supply @24V _{Dc} Consumption @24V _{Dc}	24 Vcc 0,5 A
Maximum switchable output power per single zone	500 W
Environmental operating conditions	Temperature: +5°C to +40°C / Relative humidity: 25% to 75% non-condensing
Mounting	Direct to rack 19" (1U)
Size of unit (L x H x D) Size of package (L x H x D)	482 x 44 x 220 mm 522 x 155 x 292 mm
Net weight Gross weight	4 kg 5 kg

LIST OF OPTIONAL FUNCTIONS

Clause	Description
7.6.2	Manual silencing of the voice alarm condition
7.7.2	Manual reset of the voice alarm condition
7.9	Voice alarm condition output
8.3	Indication of faults related to the transmission path
8.4	Indication of faults related to voice alarm zones
9	Disablement condition
10	Voice alarm manual control
11	Interface to external control device(s)
12	Emergency microphone(s)
13.14	Redundant power amplifiers

LIST OF AUXILIARY FUNCTIONS

Broadcast calls
Background music



**Audio
Contractor**

code: 37782



Le informazioni contenute in questo manuale sono state scrupolosamente controllate; tuttavia non si assume nessuna responsabilità per eventuali inesattezze. La FBT Elettronica S.p.A. si riserva il diritto di modificare le caratteristiche tecniche ed estetiche dei prodotti in qualsiasi momento e senza preavviso.