

**CP64S & CP52S CONNECTIONS**

Turn the power to the CP unit OFF until all connections are made.

**EUROBLOCK CONNECTIONS**

When wiring to Euroblocks, a minimum wire gauge of 22 is preferred for reliability. If the ground or shield wire is left shorter, it acts as a strain relief for the other wires. Cable with a flexible jacket is easier to use and less likely to damage the connections. Avoid stripping excess insulation. Inspect wires for nicks that may lead to wire breakage. Fully insert each wire in the appropriate socket and tighten the screw.

**REMOTE INSTALLATION**

The CP64S supports wired remotes for Page Assign (PR2) and Zone Level and Zone Source (ZR1) selection. The CP52S only supports Zone Level and Zone Source (ZR1) selection. Wire lengths of up to 1000 feet are possible. A brief list of suitable wire types is provided below in the section on Wire Types.

The **PR2** remote provides Page Zone Assign for Page 1 and Page 2 signals and is usually located at the Page source. If your application requires one of the two PAGE ASSIGN switches to control both Page 1 and Page 2 Assign, simply wire Page 1 and Page 2 control bits in parallel. You may wish to leave the knob off the unused control and cover it with one of the hole plugs provided in the kit. If your installation requires Page 1 and Page 2 remote control at two different locations, only three wires are required for each PR2 remote (Z1, Z2 & GND). As above, you may wish to leave the knob off the unused control and cover it with a hole plug.

The **ZR1** remote provides Zone Level and Source Selection, allowing local control from inside the zone. Two ZR1 remotes may be used (use only one for each Zone). If only one of the two controls is used, you may cover the unused control with one of the hole plugs provided in the kit. If you require one ZR1 remote to control both Zones, simply wire the ports in parallel. This may be done with selector only, volume only or both. If only one of the two controls is wired in parallel, the other is still available for a second remote.

When paralleling one remote across multiple CP64Ss, all three control pins must be wired, including the shields.

Power to the CP64S or CP52S should be *off* until all connections are made. It is important to ensure that the Remote Ports are not subjected to sustained voltages outside the range of 0 to 5 volts DC or high levels of static. Inputs are protected, however, caution is the better part of... you know. It is a good idea to install the wiring, connect it to the remote assemblies and then make the final connections at the CP unit. Do *not* short Vr1 or Vr2 pins to ground. These pins *are* current limited, however, excess heat is generated in the 5 volt supply if a short occurs. *Never subject the Vr1 or Vr2 pins to voltages above 5 volts.*

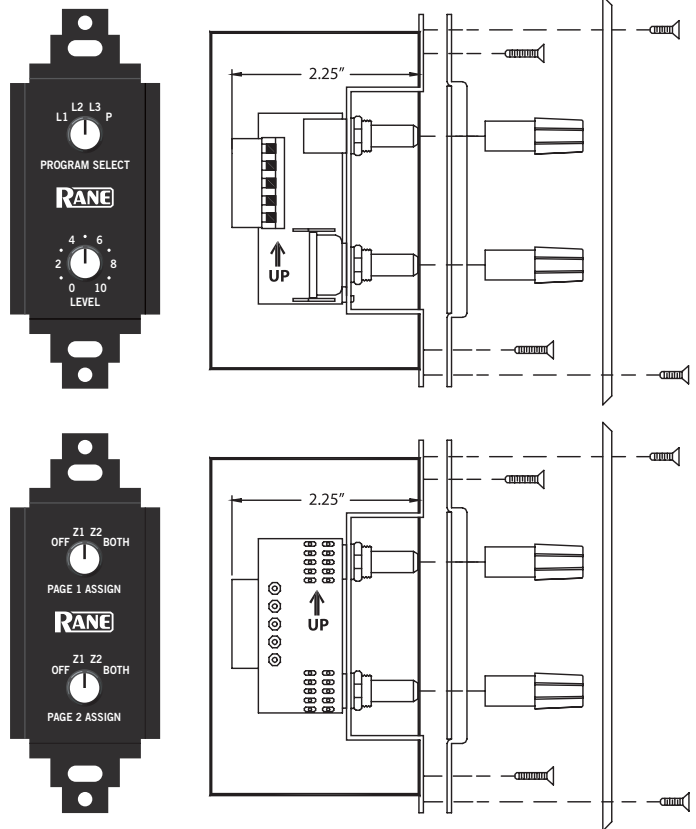

**REMOTE MOUNTING**

The ZR1 and PR2 remote assemblies mount in a standard U.S. electrical box with a minimum depth of 2.25" (5.5 cm). Be sure to note the wire color of each input in order to facilitate correct wiring to the CP unit. Connect each wire to the 5-pin connector by fully inserting it in the correct socket and tightening the screw. Make sure wires are free of nicks and that the cable jacket is stripped back sufficiently to allow it to lie in the electrical box with the remote assembly inserted. Use the flat head #6 screws supplied with the kit to mount the remote assembly and silk-screened front panel to the electrical box (see above diagram). Note the "UP" arrow screened on the printed circuit board of each remote (mount it pointing up).

Install each knob so that the line on the knob is properly aligned with the silk-screening on the front panel of the remote assembly. Install any Decora plate of your choice. For a secured installation, you may wish to leave the knobs off and use a blank Decora plate to cover the remote after adjustment.

## WIRE TYPES

Variations in wire type do not greatly affect the performance of the remote controls. However, 22-gauge stranded wire with a flexible jacket is recommended. You may use 5-conductor unshielded remote control signal cable for shorter runs (less than 200 ft.) or 4-conductor (2 pair) shielded remote control signal cable (use the shield as the GND return) for longer runs (200 to 1000 ft.). The type of wire required is influenced by your installation and local electrical codes.

Rane Corporation does *not* provide or source cable. Please contact your local retail or wholesale outlet, *not* the factory. The following is a short list of suitable cable types:

### CONSOLIDATED ELECTRONIC WIRE AND CABLE

Plenum cable:

Unshielded remote control signal cable CAT. # 9896

Shielded remote control signal cable CAT. #9877, CAT. #9852

### WEICO WIRE & CABLE INC.

Communication and control cable:

Multiconductor, unshielded CAT. #7606

### ALPHA

Communication and control cable:

Multiconductor, unshielded CAT. #1175C

### BELDEN

Unshielded remote control signal cable CAT. # 88741

Shielded remote control signal cable CAT. # 88723

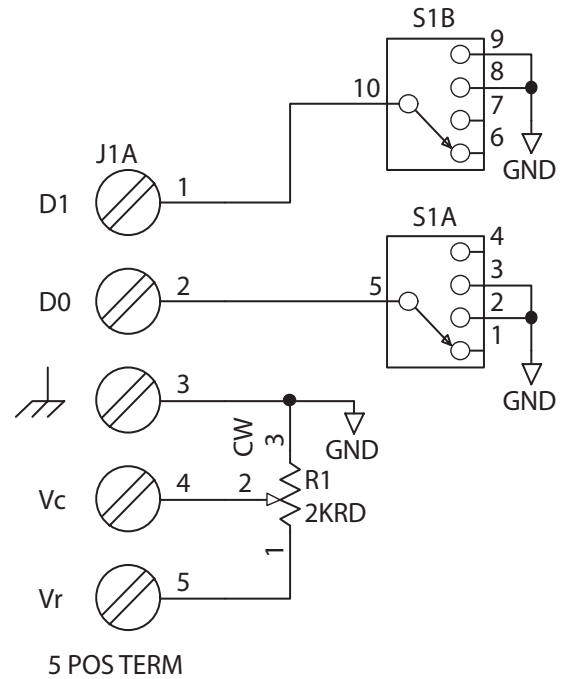

**ZONE REMOTE (ZR 1)**

PAGE 1

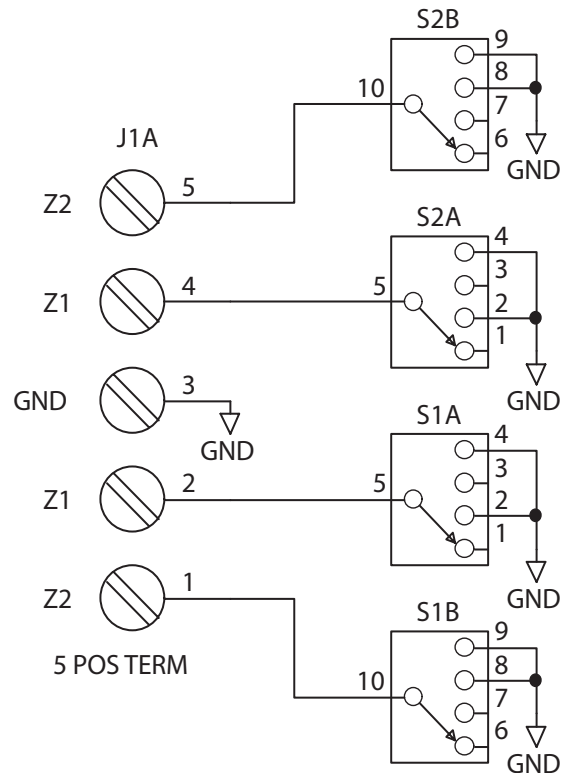

PAGE 2

**PAGE REMOTE (PR 2)**

**rhox**  
áudio e vídeo pro

