



General Description

The Rane CP66 is a multiple-input Commercial Zone Processor with paging support. Designed for versatility, it is perfect for use in restaurants, bars, offices, retail stores, stadiums, and other types of multi-zone environments.

With six Program inputs, six linkable Zone outputs, Page input, and support for the Rane PAGER2, DR1, and DR3 Digital Remotes, a multitude of system configurations are possible.

The CP66 can be configured entirely using its intuitive front panel controls, and easily set up by a technician in any location without a computer. Included Windows® software (connected through USB) provides the additional ability to save and load preconfigured settings for easy deployment, and also allows custom Zone and Group naming.

Any of the six Program inputs can be assigned to each Zone. Program Input 6 can act optionally as a gated Priority Input for use with a jukebox or notification system.

Each Zone features independent settings for:

- Level
- Source Select
- Ducker Depth
- Limiter Threshold
- 3-Band EQ
- Page Level
- High-Pass Filter
- Priority Input Enable

Page inputs are priority controlled, so a high priority input will always override the other. If Page priorities are equal, then both can be used simultaneously.

Features

- Six independent and linkable Zones.
- Six Program Inputs (4 RCA, 2 Balanced Euroblock).
- One gated Priority Input.
- Paging Inputs with Priority assign.
- Independent EQ, Limiter, Ducker depth, Filter Cutoff, Priority Enable and Page Level per Zone.

Page 1 supports an analog line or mic level input with selectable 24 V phantom power, and is assigned to Zones via a rear panel dipswitch.

Page 2 supports the optional Rane PAGER2 paging station, allowing dynamic Zone selection right at the microphone, and can store preset groups for even easier page selection. The PAGER2 connects via a single standard CAT 5 cable.

Zones may be linked into groups via rear panel switches. When linked, the Level and Source as well as any connected Remote controls are set to the same value for each Zone in the group. This allows simple but powerful linking scenarios without the need for complicated software.

The Rane Digital Remote DR1 adds remote control of Zone (or linked group) Output Level, optionally limited by configurable max and min values. The DR3 adds Input Source selection along with Level, and can be a Master Level control displaying and controlling all six Zone levels from a single location. Custom Digital Remote display names can be set in the PC software.

A dedicated transformer-isolated output delivers any Program input source to music-on-hold in a telephone system.

System security can be enabled from a local or remote switch. Options include full CP66 front panel lockout, allowing only front panel zone control, and remote muting.

The Rane CP66 includes an internal 100-240 VAC power supply and is CSA approved.

- Music-on-Hold Output (Transformer isolated).
- Front Panel lockout switch.
- Optional PAGER2 Smart Paging Station with Mic input.
- Optional DR1 Remote Zone/Group Level control.
- Optional DR3 Remote Zone/Group Input Select or Master Level.
- Universal Internal Power Supply (100-240VAC)

Program Input to Zone Output Block Diagram

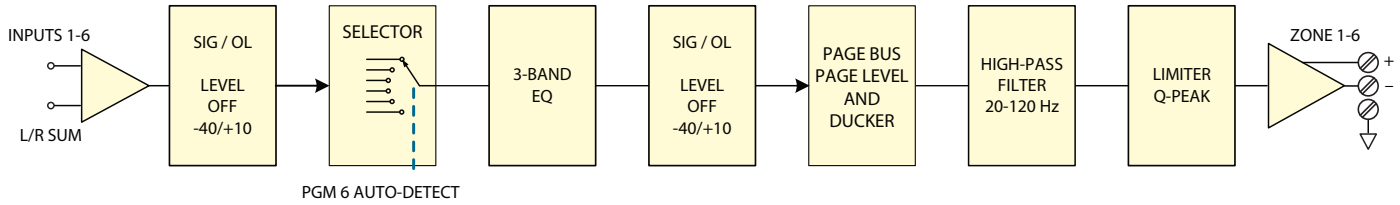

Features and Specifications

Parameter	Specification	Limit	Units	Conditions/Comments
Program Inputs 1-4				
.....Input Type	RCA			Unbalanced; Mono-summed L & R
.....Max Input Level	+14.3	+2 /-1	dBu	Equivalent to 4.0 Vrms
.....Input Level Adjust	Off to 0		dB	
.....Frequency Response	20 Hz to 22 kHz	±0.4	dB	+0 dBu, 20 Hz to 20 kHz
.....Input Impedance	17.3k	10%	Ω	
Program Inputs 5-6				
.....Input Type	Euroblock			Balanced; Mono-summed L & R
.....Max Input Level	+20	+2 /-1	dBu	
.....Input Level Adjust	Off to 0		dB	
.....Frequency Response	20 Hz to 22 kHz	±0.4	dB	+0 dBu, 20 Hz to 20 kHz
.....Input Impedance	14.0k	10%	Ω	
Page 1 Input				
.....Input Type	Euroblock			Balanced
.....Gain Range	-41 to 0		dBFS	Continuously adjustable
.....Input Mode: Line				
.....Input Impedance	5.8k	10%	Ω	
.....Max Input Level	+20		dBu	Gain set to min.
.....Input Mode: Mic				
.....Input Impedance	1.1k	10%	Ω	
.....Max Input Level	+5		dBu	Gain set to min.
.....Phantom Power	24	+4 /-0	V	10 mA max.
Zone Outputs				
.....Number of Outputs	6			Mono
.....Output Type	Euroblock		dB	Balanced
.....Max Output Level	+20	±1	dBu	
.....Frequency Response	20 Hz to 22 kHz	+0 /-3	dB	
.....THD +N	0.06	0.01	%	+4 dBu, BW=22 kHz
.....Output Impedance	100	10%	Ω	Each leg
Unit				
.....Agency Listing	CSA			
.....Universal Line Voltage	100-240 VAC, 50/60 Hz			20 watts
.....Construction	All Steel			
.....Size	3.5"H x 19"W x 8.5"D			2U (8.9 cm x 48.3 cm x 21.6 cm)
.....Weight	7 lb			(3.2 kg)
.....Shipping: Size	4.5" x 20.3" x 13.75"			(11.4 cm x 52 cm x 35 cm)
.....Weight	12 lb			(5.4 kg)

Note: 0 dBu = 0.775 Vrms

Paging Station

The PAGER2 is a Smart Paging Station that allows advanced features beyond a normal analog microphone. Specific to the CP66, this unit lets you decide which combination of the six Zones to Page into and displays important information such as whether or not a higher priority page is already occurring.

The PAGER2 accepts any standard gooseneck mic and has built-in selectable 24 V Phantom Power and a 13 dB pad. It normally sits on a desk or table, and has lockdown features for security. It connects to and is powered by the CP66 via a standard CAT 5 cable up to 100 meters in length. Labels for custom Zone and Group names may be inserted in slots on the sides of the protective Lexan faceplate.

The PAGER2 chassis is painted steel, measuring 4.5" x 6" x 2" (11.4 x 15.2 x 5.1 cm). Unit weight is 20 ounces (567 grams).



Rane PAGER2 Smart Paging Station

Digital Remotes

Digital Remotes connect to the CP66 via a single CAT5 cable.

DR1

The Rane DR1 is a Level Control remote with several features that make it stand out against any other wired remote. The LCD display shows the name of the Zone or Group that it is connected to, customizable in the CP66 Software to anything you like. The Level value is also shown, and updated dynamically when it is changed elsewhere, such as in a linked group with multiple Remotes connected. The display has a backlight for readability that turns on when used, then dims after a short time period.

The DR1 may be installed in a standard electrical box with a minimum depth of 2.25" (5.7 cm). Available in white, ivory and black, the DR1 includes a matching Decora® plate cover.

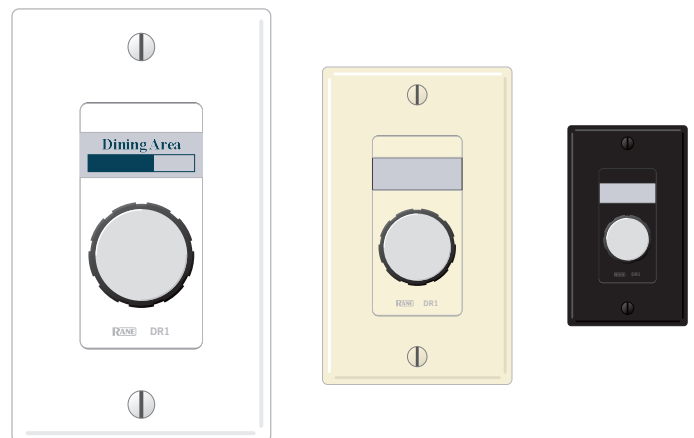

Rane DR1 Remote Level Control

DR3

The Rane DR3 also provides Level control when connected to a Zone Remote port on the CP66, with the added control of Input Source selection. This lets you select the audio source for a room from within the room itself, or anywhere else you need remote control.

The DR3 can also be used as a Master Remote on the CP66, displaying the Volume Level for all Zones and Groups and allowing you to change each of them dynamically from a single location, such as behind a bar or at a reception area.

The DR3 may be installed in a standard 2-gang electrical box with a minimum depth of 2.25" (5.7 cm). Available in white, ivory and black, the DR3 includes a matching Decora® plate cover.



Rane DR3 Remote Selection and Level Control

Rear Panel and Restaurant Application Example

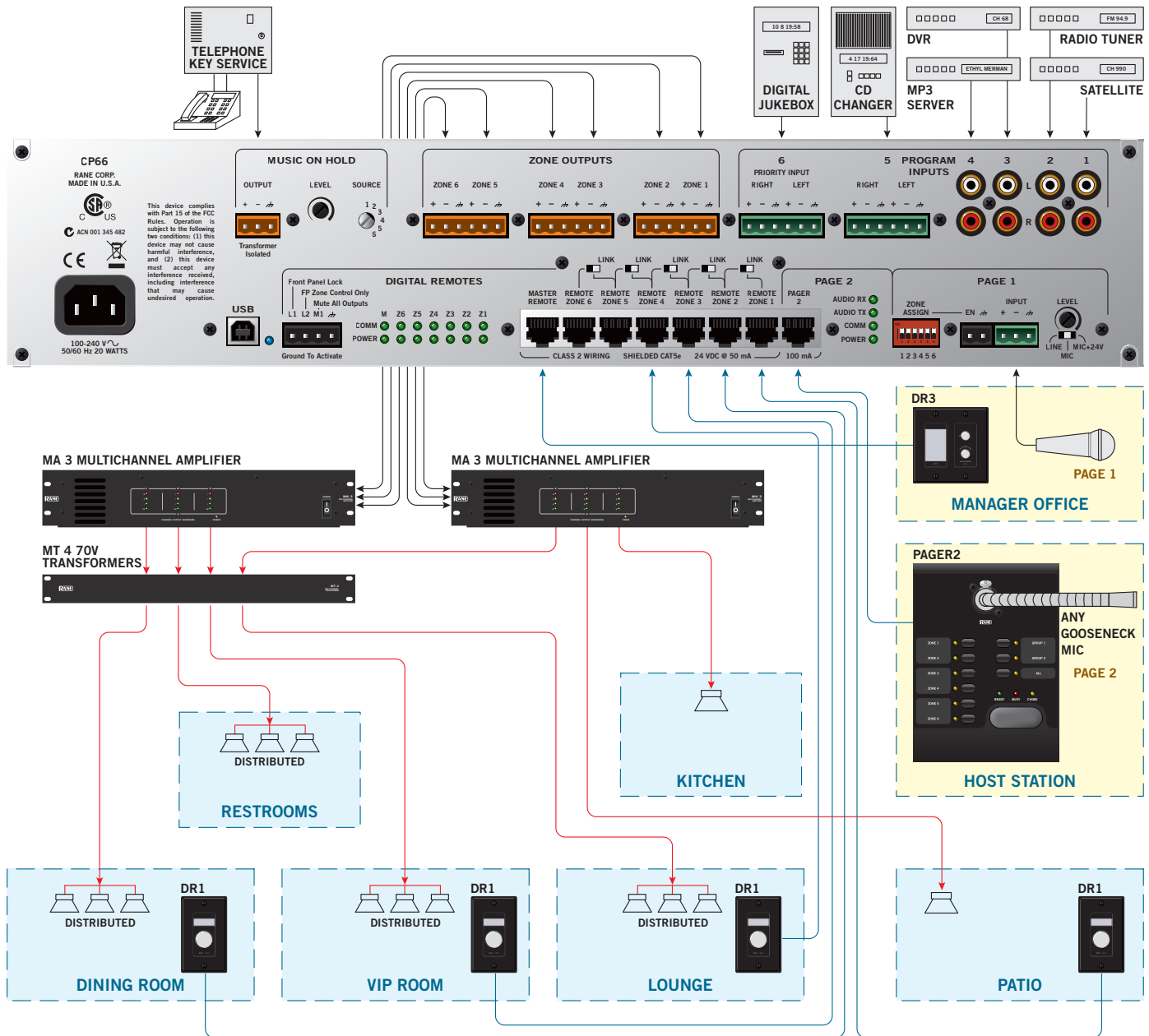

See more details and applications at rane.com/cp66.html

