



AK5385B

24Bit 192kHz $\Delta\Sigma$ ADC

GENERAL DESCRIPTION

The AK5385B is a 24bit, 192kHz sampling 2ch A/D converter for high-end audio system. The modulator in the AK5385B uses the Enhanced Dual Bit architecture and the AK5385B realizes high accuracy and low cost. The AK5385B performs 114dB dynamic range, so the device is suitable for AV-amp, AV recorder and musical instruments. The AK5385B is available in 28pin VSOP and SOP package, utilizing less board space.

FEATURES

- ❑ Sampling Rate: 8kHz ~ 216kHz
- ❑ Full Differential Inputs
- ❑ S/(N+D): 103dB
- ❑ DR: 114dB
- ❑ S/N: 114dB
- ❑ High Performance Linear Phase Digital Anti-Alias filter
 - Passband: 0~21.768kHz (@fs=48kHz)
 - Ripple: 0.005dB
 - Stopband: 100dB
- ❑ Digital HPF
- ❑ Power Supply: 5V \pm 5%(Analog), 3.0 ~ 5.25V(Digital)
- ❑ Power Dissipation: 183mW (@fs=48kHz)
- ❑ Package: 28pin SOP / 28pin VSOP
- ❑ AK5383/AK5393/AK5394A Semi-Pin compatible

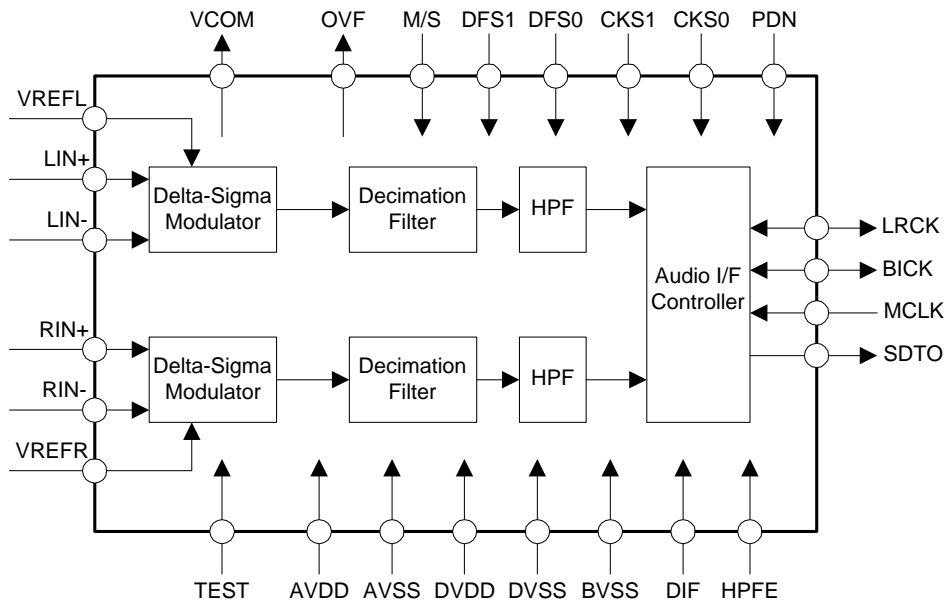

Block diagram

■ Ordering Guide

AK5385BVS	-10 ~ +70°C	28pin SOP (1.27mm pitch)
AK5385BVF	-40 ~ +85°C	28pin VSOP (0.65mm pitch)
AKD5385B	Evaluation Board for AK5385B	

■ Pin Layout

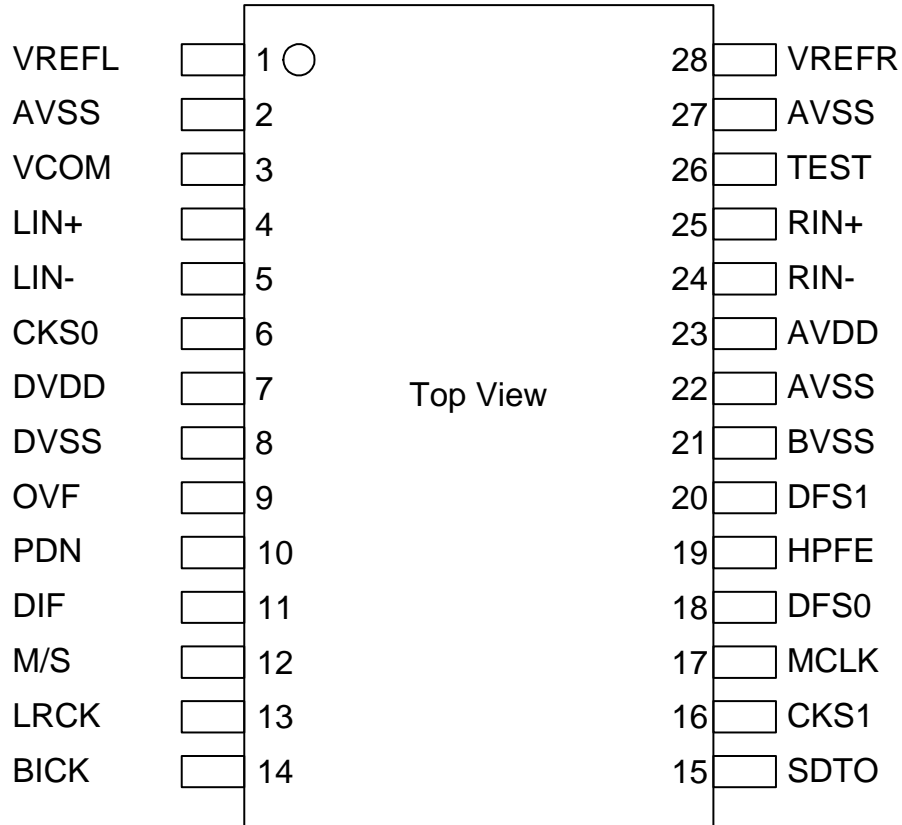

■ Compatibility with AK5383/AK5394A

	AK5385B	AK5383	AK5394A
Pin 1	VREFL	VREFL	VREFL+
Pin 2	AVSS	GNDL	VREFL-
Pin 3	VCOM	VCOML	VCOML
Pin 6	CKS0	ZCAL	ZCAL
Pin 9	OVF	CAL	CAL
Pin 11	DIF	SMODE2	SMODE2
Pin 12	M/S	SMODE1	SMODE1
Pin 16	CKS1	FSYNC	FSYNC
Pin 18	DFS0	DFS	DFS0
Pin 20	DFS1	TEST	DFS1
Pin 26	TEST	VCOMR	VCOMR
Pin 27	AVSS	GNDR	VREFR-
Pin 28	VREFR	VREFR	VREFR+
fs	8kHz ~ 216kHz	1kHz ~ 108kHz	1kHz ~ 216kHz
MCLK at 48kHz	256/384/512fs	256fs	256fs
MCLK at 96kHz	256fs	128fs	128fs
MCLK at 192kHz	128fs	Not Available	64fs
DR, S/N	114dB	110dB	123dB
Input Voltage	±2.9Vpp	±2.45Vpp	±2.4Vpp
Offset Calibration	Not Available	Available	Available

■ Compare PCB layout example between AK5385B and AK5383

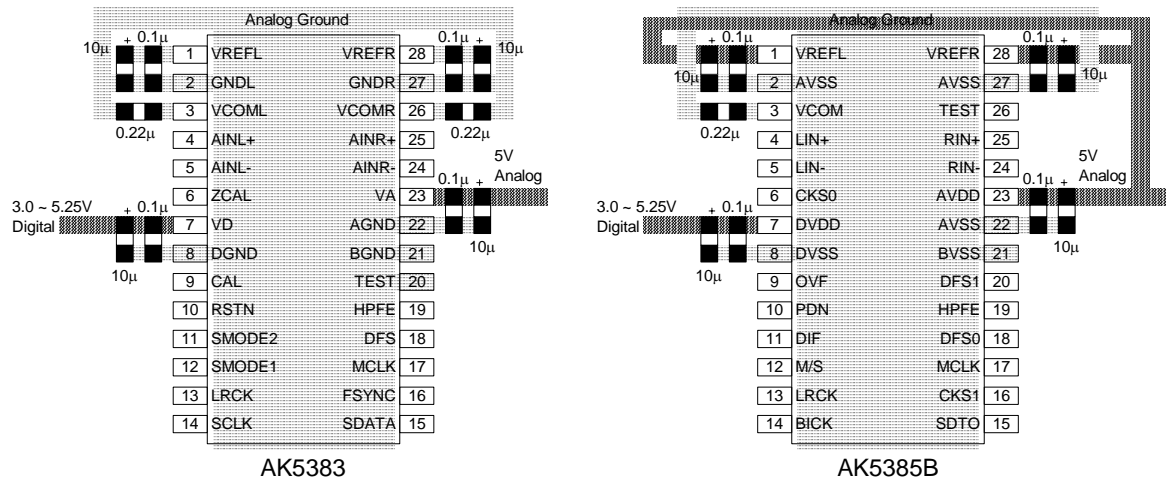

Pin #	AK5383	AK5385B
1	VREFL Lch Voltage Reference Output Pin, 3.75V Normally, connected to GNDL with a 10µF electrolytic capacitor and a 0.1µF ceramic capacitor.	VREFL Lch Voltage Reference Input Pin, AVDD Normally, connected to AVSS with a 10µF electrolytic capacitor and a 0.1µF ceramic capacitor.
6	ZCAL Zero Calibration Control Pin This pin controls the calibration reference signal.	CKS0 Master Clock Select 0 Pin (Internal Pull-down Pin, typ. 100kΩ)
9	CAL Calibration Active Signal Pin	OVF Analog Input Overflow Detect Pin
11	SMODE2 Serial Interface Mode Select Pin	DIF Audio Interface Format Pin
12	SMODE1 Serial Interface Mode Select Pin	M/S Master / Slave Mode Pin
16	FSYNC Frame Synchronization Signal Pin	CKS1 Master Clock Select 1 Pin (Internal Pull-down Pin, typ.100kΩ)
18	DFS Double Speed Sampling Mode Pin	DFS0 Sampling Speed Select 0 Pin
20	TEST Test Pin (Internal Pull-down Pin)	DFS1 Sampling Speed Select 1 Pin
26	VCOMR Rch Common Voltage Pin, 2.75V	TEST Test Pin (Internal Pull-down Pin, typ. 100kΩ)
28	VREFR Rch Voltage Reference Output Pin, 3.75V Normally, connected to GNDL with a 10µF electrolytic capacitor and a 0.1µF ceramic capacitor.	VREFR Rch Voltage Reference Input Pin, AVDD Normally, connected to AVSS with a 10µF electrolytic capacitor and a 0.1µF ceramic capacitor.

■ Compare PCB layout example between AK5385B and AK5394A

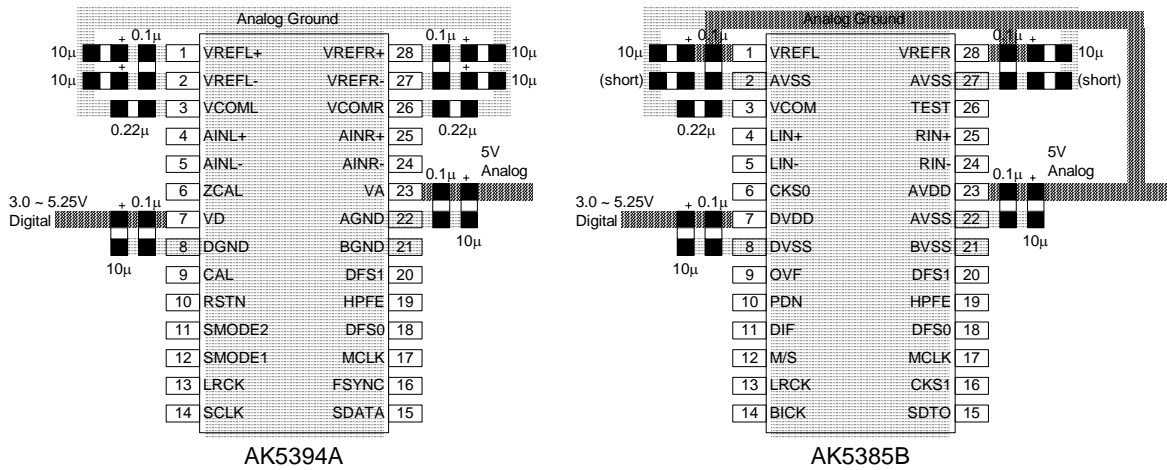

Pin #	AK5394A	AK5385B
1	VREFL+	VREFL
	Lch Positive Voltage Reference Output Pin, 3.75V Normally connected to AGND with a large electrolytic capacitor and connected to VREFL- with a 0.22µF ceramic capacitor.	Lch Voltage Reference Input Pin, AVDD Normally, connected to AVSS with a 10µF electrolytic capacitor and a 0.1µF ceramic capacitor.
2	VREFL-	AVSS
	Lch Negative Voltage Reference Output Pin, 1.25V Normally connected to AGND with a large electrolytic capacitor and connected to VREFL+ with a 0.22µF ceramic capacitor.	Analog Ground Pin
6	ZCAL	CKS0
	Zero Calibration Control Pin This pin controls the calibration reference signal.	Master Clock Select 0 Pin (Internal Pull-down Pin, typ. 100kΩ)
9	CAL	OVF
	Calibration Active Signal Pin	Analog Input Overflow Detect Pin
11	SMODE2	DIF
	Serial Interface Mode Select Pin	Audio Interface Format Pin
12	SMODE1	M/S
	Serial Interface Mode Select Pin	Master / Slave Mode Pin
16	FSYNC	CKS1
	Frame Synchronization Signal Pin	Master Clock Select 1 Pin (Internal Pull-down Pin, typ. 100kΩ)
27	VREFR-	AVSS
	Rch Negative Voltage Reference Output Pin, 1.25V Normally connected to AGND with a large electrolytic capacitor and connected to VREFR+ with a 0.22µF ceramic capacitor.	Analog Ground Pin
26	VCOMR	TEST
	Rch Common Voltage Pin, 2.75V	Test Pin (Internal Pull-down Pin, typ. 100kΩ)
28	VREFR+	VREFR
	Rch Positive Reference Output Voltage, 3.75V Normally connected to AGND with a large electrolytic capacitor and connected to VREFR- with a 0.22µF ceramic capacitor.	Rch Voltage Reference Input Pin, AVDD Normally, connected to AVSS with a 10µF electrolytic capacitor and a 0.1µF ceramic capacitor.

PIN / FUNCTION			
No.	Pin Name	I/O	Function
1	VREFL	I	Lch Voltage Reference Input Pin, AVDD Normally, connected to AVSS with a 10 μ F electrolytic capacitor and a 0.1 μ F ceramic capacitor.
2	AVSS	-	Analog Ground Pin
3	VCOM	O	Common Voltage Output Pin, AVDD/2
4	LIN+	I	Lch Analog Positive Input Pin
5	LIN-	I	Lch Analog Negative Input Pin
6	CKS0	I	Master Clock Select 0 Pin (Internal Pull-down Pin, typ. 100k Ω)
7	DVDD	-	Digital Power Supply Pin, 3.0 ~ 5.25V
8	DVSS	-	Digital Ground Pin
9	OVF	O	Analog Input Overflow Detect Pin This pin goes to "H" if analog input overflows.
10	PDN	I	Power Down Mode Pin "H": Power up, "L": Power down
11	DIF	I	Audio Interface Format Pin "H": 24bit I ² S Compatible, "L": 24bit MSB justified
12	M/S	I	Master / Slave Mode Pin "H": Master Mode, "L": Slave Mode
13	LRCK	I/O	Output Channel Clock Pin "L" Output in Master Mode at Power-down mode.
14	BICK	I/O	Audio Serial Data Clock Pin "L" Output in Master Mode at Power-down mode.
15	SDTO	O	Audio Serial Data Output Pin "L" Output at Power-down mode.
16	CKS1	I	Master Clock Select 1 Pin (Internal Pull-down Pin, typ. 100k Ω)
17	MCLK	I	Master Clock Input Pin
18	DFS0	I	Sampling Speed Select 0 Pin
19	HPFE	I	High Pass Filter Enable Pin "H": Enable, "L": Disable
20	DFS1	I	Sampling Speed Select 1 Pin
21	BVSS	-	Substrate Ground Pin
22	AVSS	-	Analog Ground Pin
23	AVDD	-	Analog Power Supply Pin, 4.75 ~ 5.25V
24	RIN-	I	Rch Analog Negative Input Pin
25	RIN+	I	Rch Analog Positive Input Pin
26	TEST	I	Test Pin (Internal Pull-down Pin, typ. 100k Ω)
27	AVSS	-	Analog Ground Pin
28	VREFR	I	Rch Voltage Reference Input Pin, AVDD Normally, connected to AVSS with a 10 μ F electrolytic capacitor and a 0.1 μ F ceramic capacitor.

Note: All digital input pins except pull-down pins should not be left floating.

■ Handling of Unused Pin

The unused I/O pins should be processed appropriately as below.

Classification	Pin Name	Setting
Analog	LIN+, LIN-	These pins should be connected to AVSS.
	RIN+, RIN-	These pins should be connected to AVSS.
	VREFL, VREFR	These pins should be connected to AVDD.
Digital	OVF	This pin should be open.
	TEST	This pin should be connected to DVSS.

ABSOLUTE MAXIMUM RATINGS

(AVSS, BVSS, DVSS=0V; Note 1)

Parameter	Symbol	min	max	Units	
Power Supplies:	Analog	AVDD	-0.3	6.0	V
	Digital	DVDD	-0.3	6.0	V
	BVSS – DVSS (Note 2)	ΔGND	-	0.3	V
Input Current, Any Pin Except Supplies	IIN	-	±10	mA	
Analog Input Voltage (LIN+/-, RIN+/-, VREFL/R pins)	VINA	-0.3	AVDD+0.3	V	
Digital Input Voltage (All digital input pins)	VIND	-0.3	DVDD+0.3	V	
Ambient Temperature (Power applied)	28SOP Package	Ta	-10	70	°C
	28VSOP Package	Ta	-40	85	°C
Storage Temperature	Tstg	-65	150	°C	

Note 1. All voltages with respect to ground.

Note 2. AVSS, BVSS, and DVSS must be connected to the same analog ground plane.

WARNING: Operation at or beyond these limits may result in permanent damage to the device.
Normal operation is not guaranteed at these extremes.

RECOMMENDED OPERATING CONDITIONS

(AVSS, BVSS, DVSS=0V; Note 1)

Parameter	Symbol	min	typ	max	Units	
Power Supplies (Note 3)	Analog	AVDD	4.75	5.0	5.25	V
	Digital	DVDD	3.0	3.3	AVDD	V
Voltage Reference (VREFL/R pins)	VREF	3.0	-	AVDD	V	

Note 1. All voltages with respect to ground.

Note 3. The power up sequence between AVDD and DVDD is not critical.

WARNING: AKM assumes no responsibility for the usage beyond the conditions in this datasheet.

ANALOG CHARACTERISTICS

(Ta=25°C; AVDD=5.0V, DVDD=3.3V; AVSS=BVSS=DVSS=0V; VREFL=VREFR=AVDD; fs=48kHz, 96kHz, 192kHz; BICK=64fs; Signal Frequency=1kHz; 24bit Data; Measurement frequency=20Hz ~ 20kHz at fs=48kHz, 40Hz ~ 40kHz at fs=96kHz, 40Hz ~ 40kHz at fs=192kHz; unless otherwise specified)

Parameter		min	typ	max	Units
Analog Input Characteristics:					
Resolution				24	Bits
Input Voltage (Note 4)		±2.7	±2.9	±3.1	Vpp
S/(N+D)	fs=48kHz BW=20kHz	-1dBFS (Note 5)	-	103	dB
		-1dBFS	92	100	dB
		-20dBFS	-	91	dB
		-60dBFS	-	51	dB
	fs=96kHz BW=40kHz	-1dBFS	90	98	dB
		-20dBFS	-	86	dB
		-60dBFS	-	46	dB
	fs=192kHz BW=40kHz	-1dBFS	-	98	dB
		-20dBFS	-	86	dB
-60dBFS		-	46	dB	
Dynamic Range (-60dBFS with A-weighted)		107	114		dB
S/N (A-weighted)		107	114		dB
Input Resistance		9	13		kΩ
Interchannel Isolation		100	120		dB
Interchannel Gain Mismatch			0.1	0.5	dB
Power Supply Rejection (Note 6)			50	-	dB
Power Supplies					
Power Supply Current					
Normal Operation (PDN pin = "H")					
AVDD			30	45	mA
DVDD	(fs=48kHz)		10	15	mA
DVDD	(fs=96kHz)		17	25	mA
DVDD	(fs=192kHz)		20	30	mA
Power down mode (PDN pin = "L") (Note 7)					
AVDD+DVDD			10	100	μA

Note 4. This value is (LIN+)-(LIN-) and (RIN+)-(RIN-). Input voltage is proportional to VREF voltage.

$$V_{in} = 0.58 \times V_{REF} (V_{pp})$$

Note 5. 100μF capacitors are connected between the VREFL/R pins and AVSS.

Note 6. PSR is applied to AVDD and DVDD with 1kHz, 20mVpp. The VREFL and VREFR pins held a constant voltage.

Note 7. All digital input pins are held DVDD or DVSS.

FILTER CHARACTERISTICS (fs=48kHz)						
(Ta=25°C; AVDD=4.75 ~ 5.25V; DVDD=3.0 ~ 5.25V; DFS1 = "L", DFS0 = "L")						
Parameter	Symbol	min	typ	max	Units	
ADC Digital Filter (Decimation LPF):						
Passband (Note 8)	-0.005dB	PB	0		21.5	kHz
	-0.02dB		-	22.038	-	kHz
	-0.06dB		-	22.2	-	kHz
	-6.0dB		-	24.0	-	kHz
Stopband	SB	26.5				kHz
Passband Ripple	PR			±0.005		dB
Stopband Attenuation	SA	100				dB
Group Delay (Note 9)	GD		43.2			1/fs
Group Delay Distortion	ΔGD		0			μs
ADC Digital Filter (HPF):						
Frequency Response (Note 8)	-3dB	FR		1.0		Hz
	-0.1dB			6.5		Hz

FILTER CHARACTERISTICS (fs=96kHz)						
(Ta=25°C; AVDD=4.75 ~ 5.25V; DVDD=3.0 ~ 5.25V; DFS1 = "L", DFS0 = "H")						
Parameter	Symbol	min	typ	max	Units	
ADC Digital Filter (Decimation LPF):						
Passband (Note 8)	-0.005dB	PB	0		43.0	kHz
	-0.02dB		-	44.081	-	kHz
	-0.06dB		-	44.5	-	kHz
	-6.0dB		-	48.0	-	kHz
Stopband	SB	53.0				kHz
Passband Ripple	PR			±0.005		dB
Stopband Attenuation	SA	100				dB
Group Delay (Note 9)	GD		43.1			1/fs
Group Delay Distortion	ΔGD		0			μs
ADC Digital Filter (HPF):						
Frequency Response (Note 8)	-3dB	FR		2.0		Hz
	-0.1dB			13.0		Hz

Note 8. The passband and stopband frequencies scale with fs. The reference frequency of these responses is 1kHz.

Note 9. The calculated delay time induced by digital filtering. This time is from the input of an analog signal to the setting of 24bit data both channels to the ADC output register for ADC.

FILTER CHARACTERISTICS (fs=192kHz)						
(Ta=25°C; AVDD=4.75 ~ 5.25V; DVDD=3.0 ~ 5.25V; DFS1 = "H", DFS0 = "L")						
Parameter	Symbol	min	typ	max	Units	
ADC Digital Filter (Decimation LPF):						
Passband (Note 8)	-0.005dB	PB	0		86.0	kHz
	-0.02dB		-	88.183	-	kHz
	-0.06dB		-	89.0	-	kHz
	-6.0dB		-	96.0	-	kHz
Stopband	SB	106.0				kHz
Passband Ripple	PR			±0.005		dB
Stopband Attenuation	SA	100				dB
Group Delay (Note 9)	GD		38.2			1/fs
Group Delay Distortion	ΔGD		0			μs
ADC Digital Filter (HPF):						
Frequency Response (Note 8)	-3dB	FR		4.0		Hz
	-0.1dB			26.0		Hz

Note 8. The passband and stopband frequencies scale with fs. The reference frequency of these responses is 1kHz.

Note 9. The calculated delay time induced by digital filtering. This time is from the input of an analog signal to the setting of 24bit data both channels to the ADC output register for ADC.

DC CHARACTERISTICS					
(Ta=25°C; AVDD=4.75 ~ 5.25V; DVDD=3.0 ~ 5.25V)					
Parameter	Symbol	min	typ	Max	Units
High-Level Input Voltage	VIH	70% DVDD	-	-	V
Low-Level Input Voltage	VIL	-	-	30% DVDD	V
High-Level Output Voltage (Iout=-400μA)	VOH	DVDD-0.4	-	-	V
Low-Level Output Voltage (Iout=400μA)	VOL	-	-	0.4	V
Input Leakage Current (Note 10)	Iin	-	-	±10	μA

Note 10. CKS1, CKS0 and TEST pins are internally connected to a pull-down resistor. (typ. 100kΩ)

SWITCHING CHARACTERISTICS						
(Ta=25°C; AVDD=4.75 ~ 5.25V; DVDD=3.0 ~ 5.25V; CL=20pF)						
Parameter	Symbol	min	typ	max	Units	
Master Clock Timing						
Frequency	fCLK	2.048		27.648	MHz	
Pulse Width Low	tCLKL	14.5			ns	
Pulse Width High	tCLKH	14.5			ns	
LRCK Frequency						
Normal Speed Mode	f _{sn}	8		54	kHz	
Double Speed Mode	f _{sd}	54		108	kHz	
Quad Speed Mode	f _{sq}	108		216	kHz	
Duty Cycle	Slave mode	45		55	%	
	Master mode		50		%	
Audio Interface Timing						
Slave mode						
BICK Period						
Normal Speed Mode	tBCK	1/128f _{sn}			ns	
Double Speed Mode	tBCK	1/64f _{sd}			ns	
Quad Speed Mode	tBCK	1/64f _{sq}			ns	
BICK Pulse Width Low	tBCKL	33			ns	
Pulse Width High	tBCKH	33			ns	
LRCK Edge to BICK “↑”	tLRB	20			ns	
BICK “↑” to LRCK Edge	tBLR	20			ns	
LRCK to SDTO (MSB) (Except I ² S mode)	tLRS			20	ns	
BICK “↓” to SDTO	tBSD			20	ns	
Master mode						
BICK Frequency	fBCK		64fs		Hz	
BICK Duty	dBCK		50		%	
BICK “↓” to LRCK	tMBLR	-20		20	ns	
BICK “↓” to SDTO	tBSD	-20		20	ns	
Reset Timing						
PDN Pulse Width	tPD	150			ns	
PDN “↑” to SDTO valid	tPDV		516		1/fs	

Note 11. BICK rising edge must not occur at the same time as LRCK edge.

Note 12. The AK5385B can be reset by bringing the PDN pin = “L”.

Note 13. This cycle is the number of LRCK rising edges from the PDN pin = “H”. This value is in master mode
This value is longer 1/fs in slave mode than master mode.

■ Timing Diagram

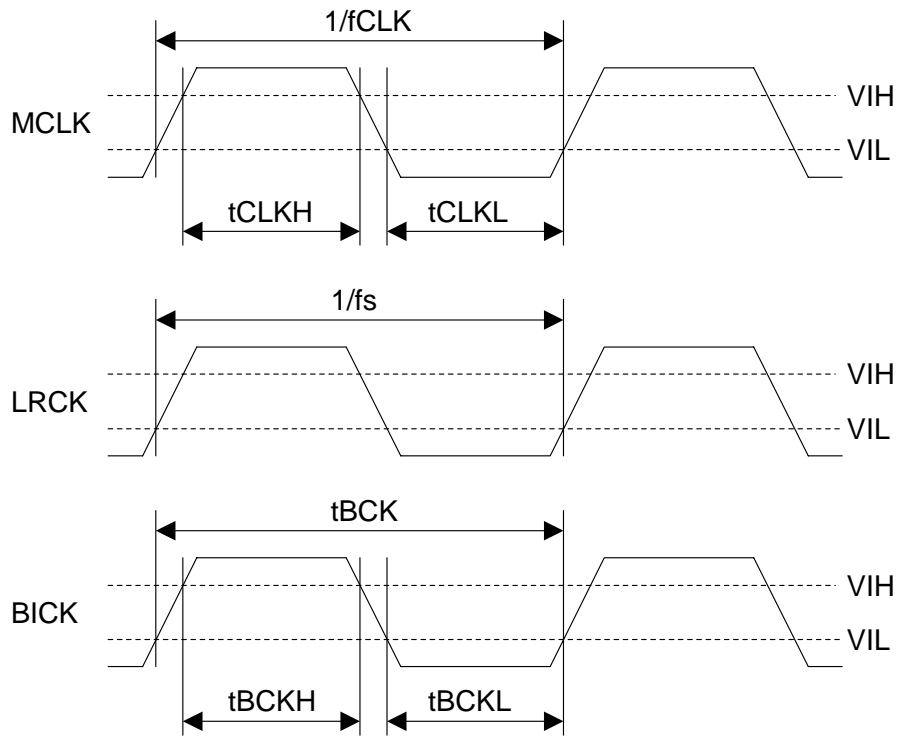

Clock Timing

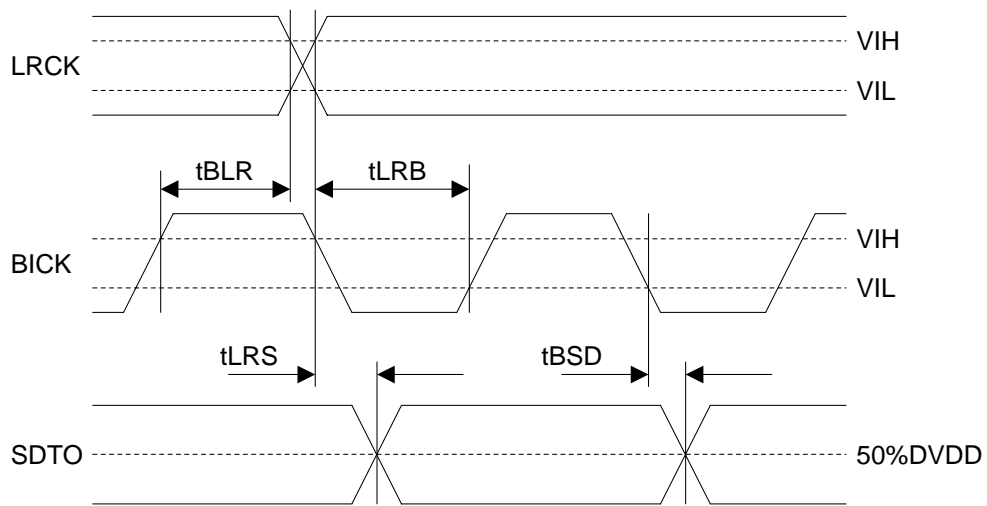

Audio Interface Timing (Slave mode)

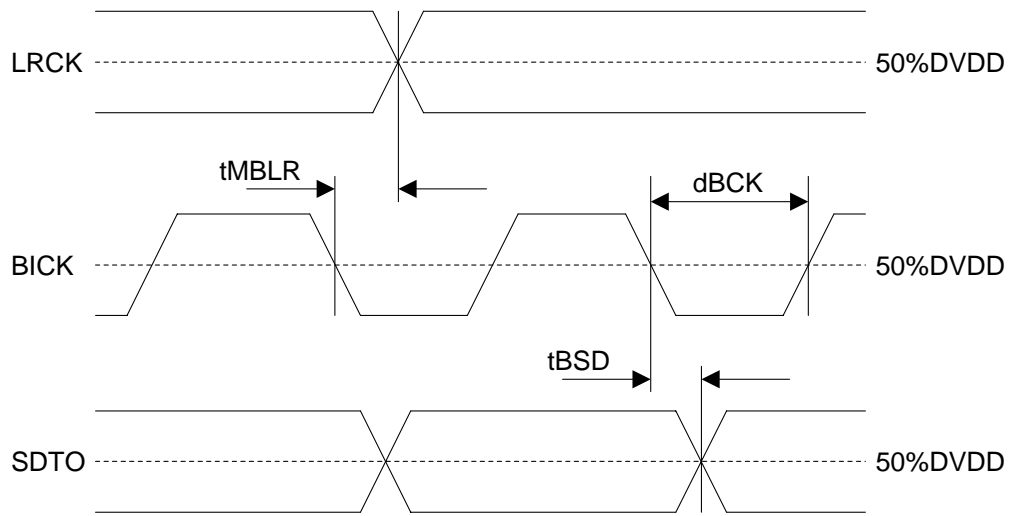

Audio Interface Timing (Master mode)

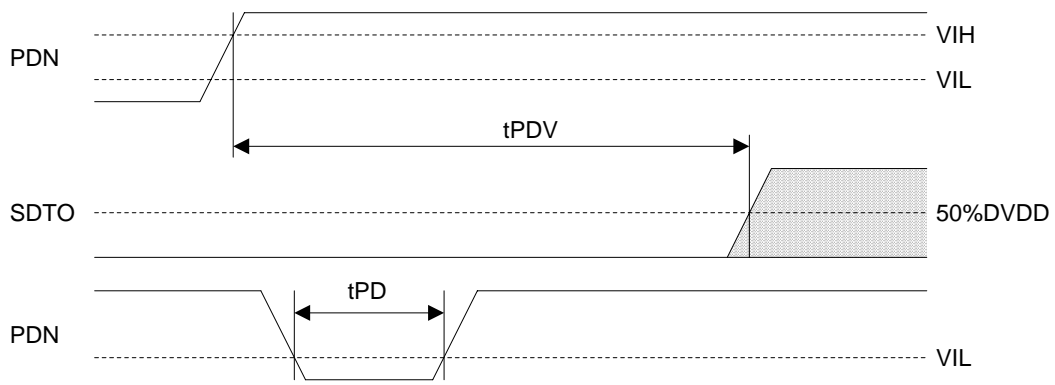

Power Down & Reset Timing

OPERATION OVERVIEW

■ System Clock

MCLK (256fs/384fs/512fs), BICK (48fs~) and LRCK (fs) clocks are required in slave mode. The LRCK clock input must be synchronized with MCLK, however the phase is not critical. Table 1 shows the relationship of typical sampling frequency and the system clock frequency. MCLK frequency is selected by CKS1-0 pins as shown in Table 2 and LRCK frequency is selected by DFS1-0 pins as shown in Table 3.

As the AK5385B includes the phase detect circuit for LRCK, the AK5385B is reset automatically when the synchronization is out of phase by changing the clock frequencies.

All external clocks (MCLK, BICK and LRCK) must be present unless PDN pin = "L". If these clocks are not provided, the AK5385B may draw excess current due to its use of internal dynamically refreshed logic. If the external clocks are not present, place the AK5385B in power-down mode (PDN pin = "L"). In master mode, the master clock (MCLK) must be provided unless PDN pin = "L".

fs	MCLK			
	128fs	256fs	384fs	512fs
32kHz	N/A	8.192MHz	12.288MHz	16.384MHz
44.1kHz	N/A	11.2896MHz	16.9344MHz	22.5792MHz
48kHz	N/A	12.288MHz	18.432MHz	24.576MHz
96kHz	N/A	24.576MHz	N/A	N/A
192kHz	24.576MHz	N/A	N/A	N/A

Table 1. System Clock Example

CKS1 pin	CKS0 pin	MCLK Frequency
L	L	256fs
L	H	128fs
H	L	512fs
H	H	384fs

Table 2. MCLK Frequency

DFS1 pin	DFS0 pin	LRCK Frequency
L	L	$8\text{kHz} \leq fs \leq 54\text{kHz}$
L	H	$54\text{kHz} < fs \leq 108\text{kHz}$
H	L	$108\text{kHz} < fs \leq 216\text{kHz}$
H	H	N/A

Table 3. Sampling Speed

When changing MCLK frequency in master/slave mode, the AK5385B should reset by PDN pin = "L". (ex. 12.288MHz(@fs=48kHz) to 24.576MHz(@fs=96kHz) at CKS1 pin = CKS0 pin = "L").

If the CKS1-0 and DFS1-0 pins are changed with same MCLK frequency in master/slave mode (ex. MCLK is fixed to 24.576MHz and fs is changed from 48kHz (CKS1 pin = "L", CKS0 pin = "L") to 96kHz (CKS1 pin = "L", CKS0 pin = "H")), no reset by PDN pin = "L" is required.

■ Audio Interface Format

Two kinds of data formats can be chosen with the DIF pin (Table 4). In both modes, the serial data is in MSB first, 2's complement format. The SDTO is clocked out on the falling edge of BICK. The audio interface supports both master and slave modes. In master mode, BICK and LRCK are output with the BICK frequency fixed to 64fs and the LRCK frequency fixed to 1fs.

Mode	DIF pin	SDTO	LRCK	BICK	Figure
0	L	24bit, MSB justified	H/L	≥ 48fs	Figure 1
1	H	24bit, I ² S Compatible	L/H	≥ 48fs	Figure 2

Table 4. Audio Interface Format

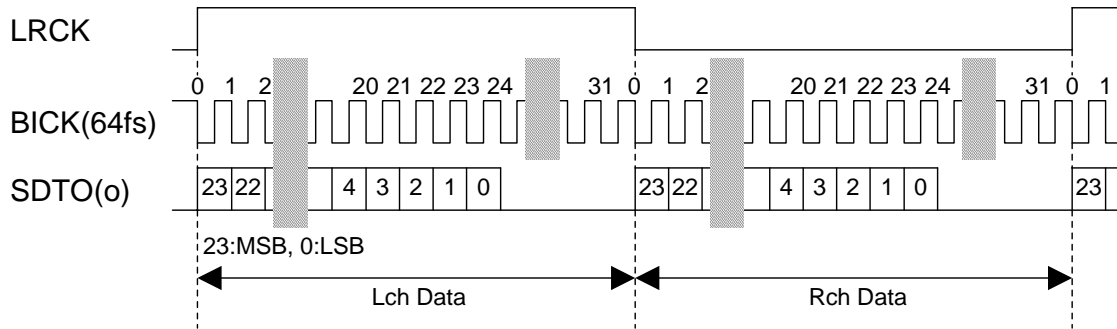

Figure 1. Mode 0 Timing

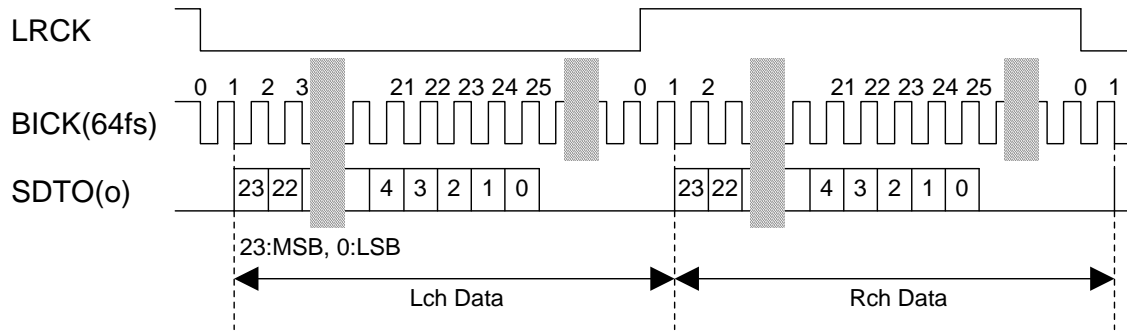

Figure 2. Mode 1 Timing

■ Master Mode and Slave Mode

The M/S pin selects either master or slave modes. M/S pin = "H" selects master mode and "L" selects slave mode. The AK5385B outputs BICK and LRCK in master mode. In slave mode, provide MCLK, BICK and LRCK.

M/S pin	Mode	BICK, LRCK
L	Slave Mode	BICK = Input LRCK = Input
H	Master Mode	BICK = Output LRCK = Output

Table 5. Master mode/Slave mode

■ Digital High Pass Filter

The ADC has a digital high pass filter for DC offset cancellation. The cut-off frequency of the HPF is 1.0Hz (@fs=48kHz) and scales with sampling rate (fs).

HPF is controlled by HPFE pin. If HPF setting (ON/OFF) is changed at operating, click noise occurs by changing DC offset. It is recommended that HPF setting is changed at PDN pin = "L".

■ Overflow Detection

The AK5385B has overflow detect function for analog input. OVF pin goes to "H" if Lch or Rch overflows (more than -0.3dBFS). OVF output for overflowed analog input has the same group delay as ADC ($GD=43.2/fs=0.9ms@fs=48kHz$). OVF is "L" for $516/fs$ ($=10.75ms@fs=48kHz$) after PDN pin = "↑", and then overflow detection is enabled.

■ Power Down and Reset

The AK5385B is placed in the power-down mode by bringing PDN pin "L" and the digital filter is also reset at the same time. This reset should always be done after power-up. In the power-down mode, the VCOM is AGND level. An analog initialization cycle starts after exiting the power-down mode. Therefore, the output data SDTO becomes available after 516 cycles of LRCK clock in master mode (517 cycles in slave mode). During initialization, the ADC digital data outputs of both channels are forced to "0". The ADC outputs settle in the data corresponding to the input signals after the end of initialization (Settling approximately takes the group delay time).

The AK5385B should be reset once by bringing PDN pin "L" after power-up. The internal timing starts clocking by the rising edge (falling edge at Mode 1) of LRCK after exiting from reset and power down state by MCLK.

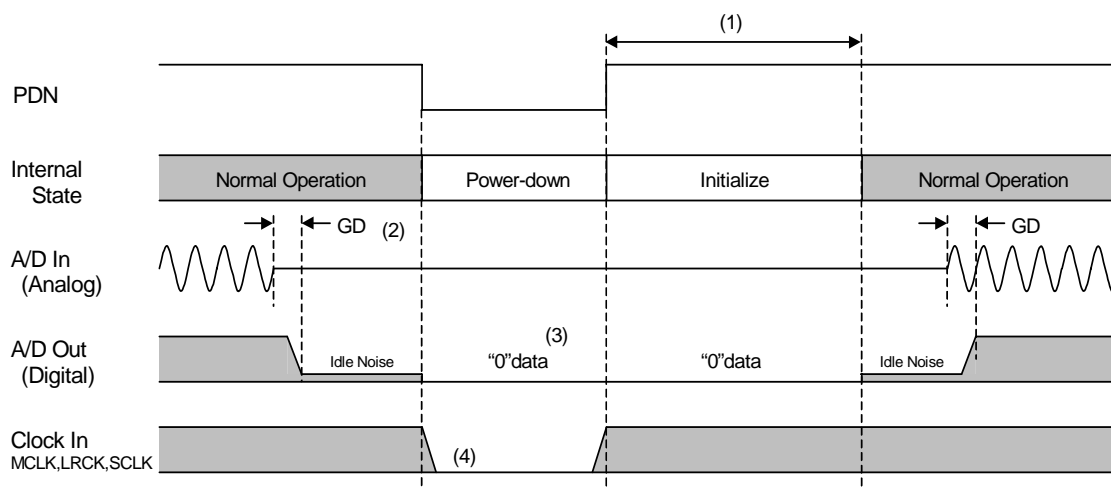

Notes:

- (1) $517/fs$ in slave mode and $516/fs$ in master mode.
- (2) Digital output corresponding to analog input has the group delay (GD).
- (3) A/D output is "0" data at the power-down state.
- (4) When the external clocks (MCLK, SCLK, LRCK) are stopped, the AK5385B should be in the power-down state.

Figure 3. Power-down/up sequence example

SYSTEM DESIGN

Figure 4 shows the system connection diagram. An evaluation board is available which demonstrates application circuits, the optimum layout, power supply arrangements and measurement results.

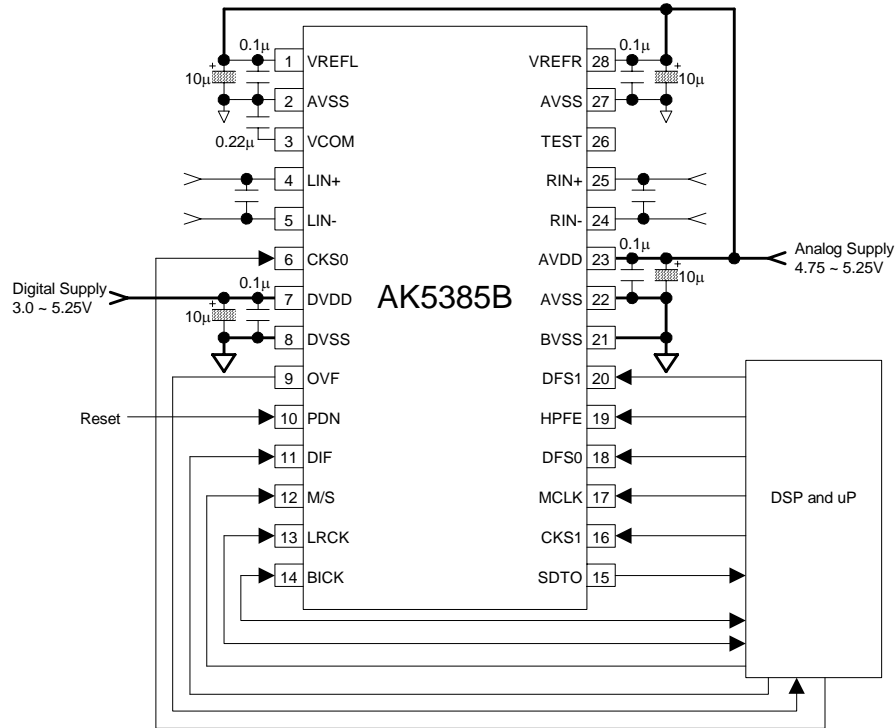

- Note:
- AVSS, BVSS and DVSS of the AK5385B should be distributed separately from the ground of external digital devices (MPU, DSP etc.).
 - All input pins except pull-down (CKS0, CKS1 and TEST pin) pin should not be left floating.

Figure 4. Typical Connection Diagram

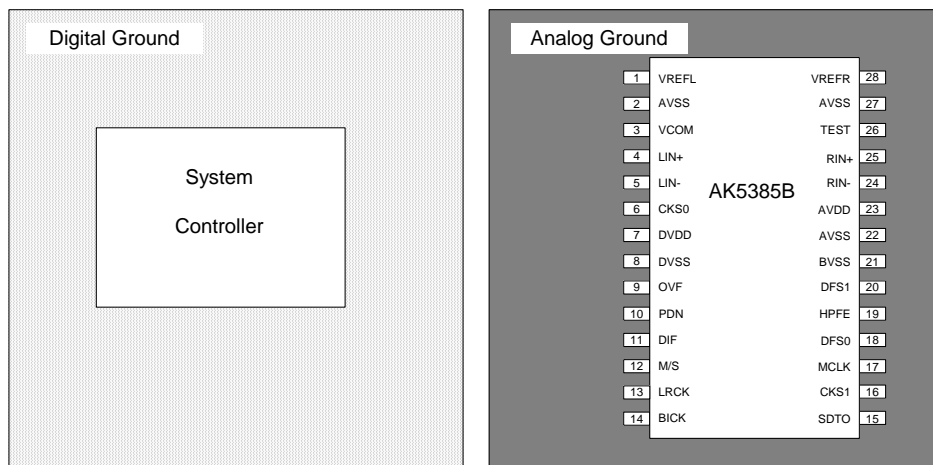

Figure 5. Ground Layout

- Note:
- AVSS, BVSS, and DVSS must be connected to the same analog ground plane.

1. Grounding and Power Supply Decoupling

The AK5385B requires careful attention to power supply and grounding arrangements. Alternatively if AVDD and DVDD are supplied separately, the power up sequence is not critical. **AVSS, BVSS and DVSS of the AK5385B must be connected to analog ground plane.** System analog ground and digital ground should be connected together near to where the supplies are brought onto the printed circuit board. Decoupling capacitors should be as near to the AK5385B as possible, with the small value ceramic capacitor being the nearest.

2. Voltage Reference Inputs

The reference voltage for A/D converter is supplied from VREFL/R pins at AVSS reference. AVSS pin is connected to analog ground and an electrolytic capacitor over 10 μ F parallel with a 0.1 μ F ceramic capacitor between the VREFL/R pins and the AVSS pin eliminate the effects of high frequency noise. Especially, a ceramic capacitor should be as near to the pins as possible. And all digital signals, especially clocks, should be kept away from the VREFL/R pins in order to avoid unwanted coupling into the AK5385B. No load current may be taken from the VREFL/R pins.

VCOM is a signal ground of this chip. An electrolytic capacitor 0.22 μ F attached to VCOM pin eliminates the effects of high frequency noise. No load current may be drawn from the VCOM pin. All signals, especially clocks, should be kept away from the VCOM pin in order to avoid unwanted coupling into the AK5385B.

3. Analog Inputs

Analog signal is differentially input into the modulator via the LIN+ (RIN+) and the LIN- (RIN-) pins. The input voltage is the difference between the LIN+ (RIN+) and LIN- (RIN-) pins. The full scale of each pin is nominally $\pm 2.9V_{pp}$ (typ). The AK5385B can accept input voltages from AVSS to AVDD. The ADC output data format is 2's complement. The internal HPF removes the DC offset.

The AK5385B samples the analog inputs at 128fs (6.144MHz@fs=48kHz, Normal Speed Mode). The digital filter rejects noise above the stop band except for multiples of 128fs. The AK5385B includes an anti-aliasing filter (RC filter) to attenuate a noise around 128fs.

The AK5385B accepts +5V supply voltage. Any voltage which exceeds the upper limit of AVDD+0.3V and lower limit of AVSS-0.3V and any current beyond 10mA for the analog input pins (LIN+/-, RIN+/-) should be avoided. Excessive currents to the input pins may damage the device. Hence input pins must be protected from signals at or beyond these limits. Use caution specially in case of using $\pm 15V$ in other analog circuits.

4. External Analog Circuit Examples

Figure 6 shows an input buffer circuit example 1. This is a full-differential input buffer circuit with an inverted-amp (gain: -10dB). The capacitor of 10nF between LIN+/- (RIN+/-) decreases the clock feed through noise of modulator, and composes a 1st order LPF (fc=360kHz) with 22Ω resistor before the capacitor. This circuit also has a 1st order LPF (fc=370kHz) composed of op-amp. The evaluation board should be referred about the detail.

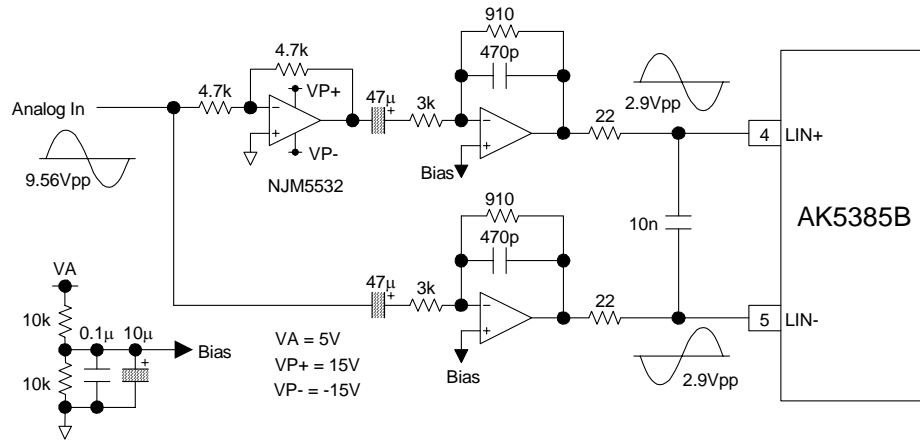

Figure 6. Input Buffer example

Figure 7 shows an input buffer circuit example 2. (1st order HPF: fc=0.66Hz, Table 6; 1st order LPF: fc=590kHz, gain=-14dB, Table 7). The analog signal is able to input through XLR or BNC connectors. (short JP1 and JP2 for BNC input, open JP1 and JP2 for XLR input). The input level of this circuit is +/-14.7Vpp.

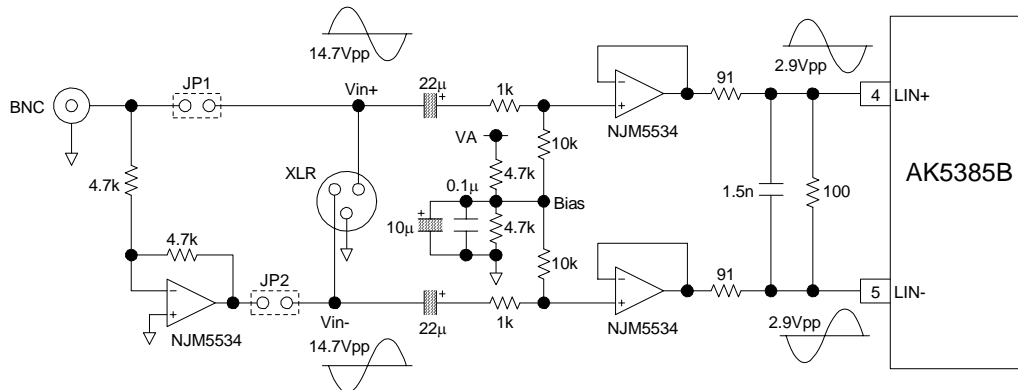

Figure 7. Input Buffer example

fin	1Hz	10Hz
Frequency Response	-1.56dB	-0.02dB

Table 6. Frequency Response of HPF

fin	20kHz	40kHz	6.144MHz
Frequency Response	-0.005dB	-0.02dB	-15.6dB

Table 7. Frequency Response of LPF

5. Measurement Example

Figure 8 shows the $S/(N+D)$ vs. VREF capacitor that is connected between VREFL/R pins and AVSS pin with the $0.1\mu\text{F}$ capacitor in parallel. X-AXIS is the capacity for VREF; Y-AXIS is $S/(N+D)$.

[Measurement Condition]

- AVDD = 5.0V, DVDD = 3.3V; AVSS = BVSS = DVSS = 0V
- $f_s = 48\text{kHz}$
- Measurement Bandwidth = 10Hz ~ 20kHz
- $T_a = 25^\circ\text{C}$
- Using Audio Precision System Two Cascade

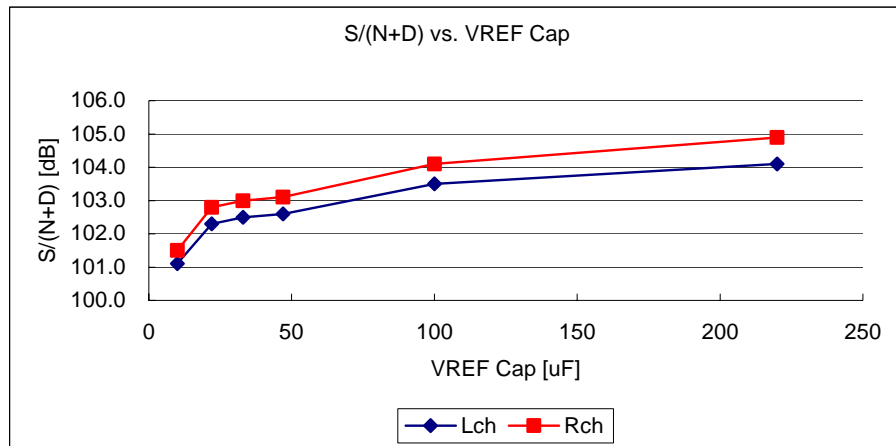

Figure 8. $S/(N+D)$ vs. VREF Cap

6. Synchronization of Multiple Devices

In system where multiple ADCs are required, care must be taken to achieve simultaneous sampling. To ensure synchronous sampling, the MCLK and LRCK must be the same for all of the AK5385Bs in the system. The all AK5385Bs should be reset at the same timing with preventing the reset signal for AK5385B from overlapping on the edge of MCLK, so that all AK5385Bs begin sampling on the same clock edge.

PACKAGE (AK5385BVF)

28pin VSOP (Unit: mm)

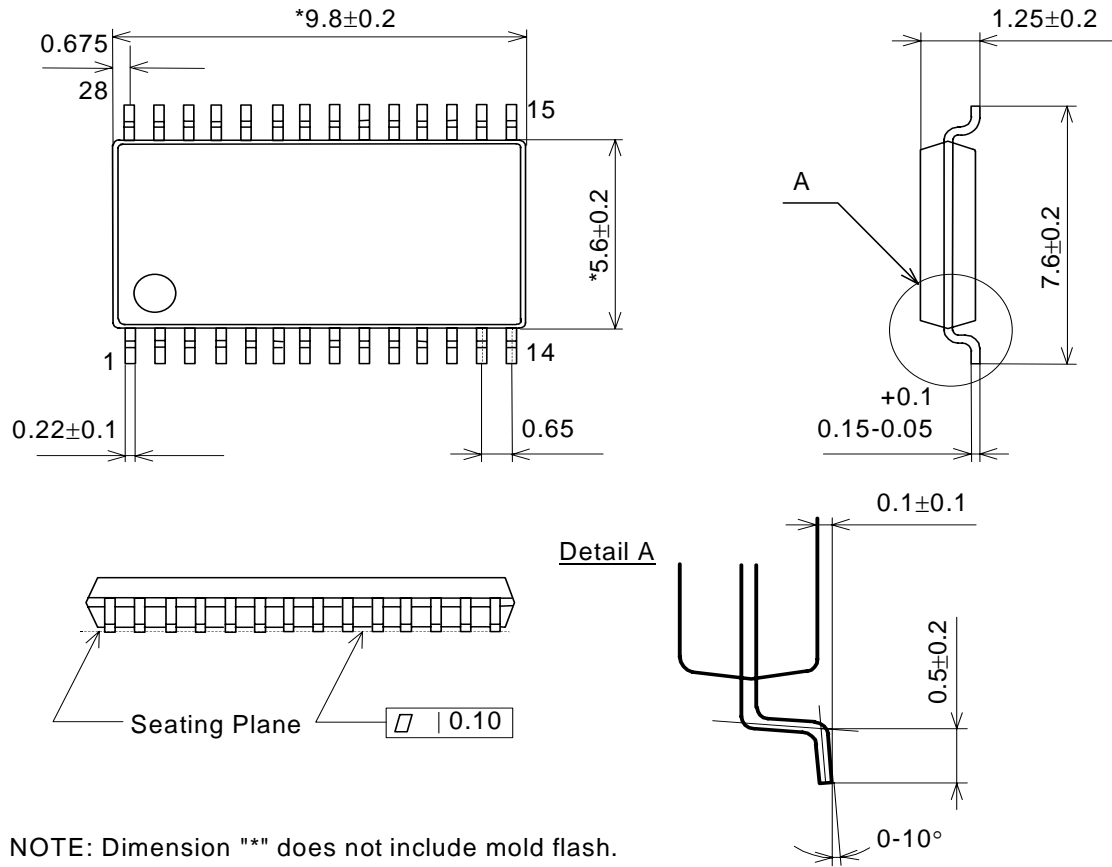

NOTE: Dimension "*" does not include mold flash.

Material & Lead finish

Package molding compound:	Epoxy
Lead frame material:	Cu
Lead frame surface treatment:	Solder (Pb free) plate

PACKAGE (AK5385BVS)

28pin SOP (Unit: mm)

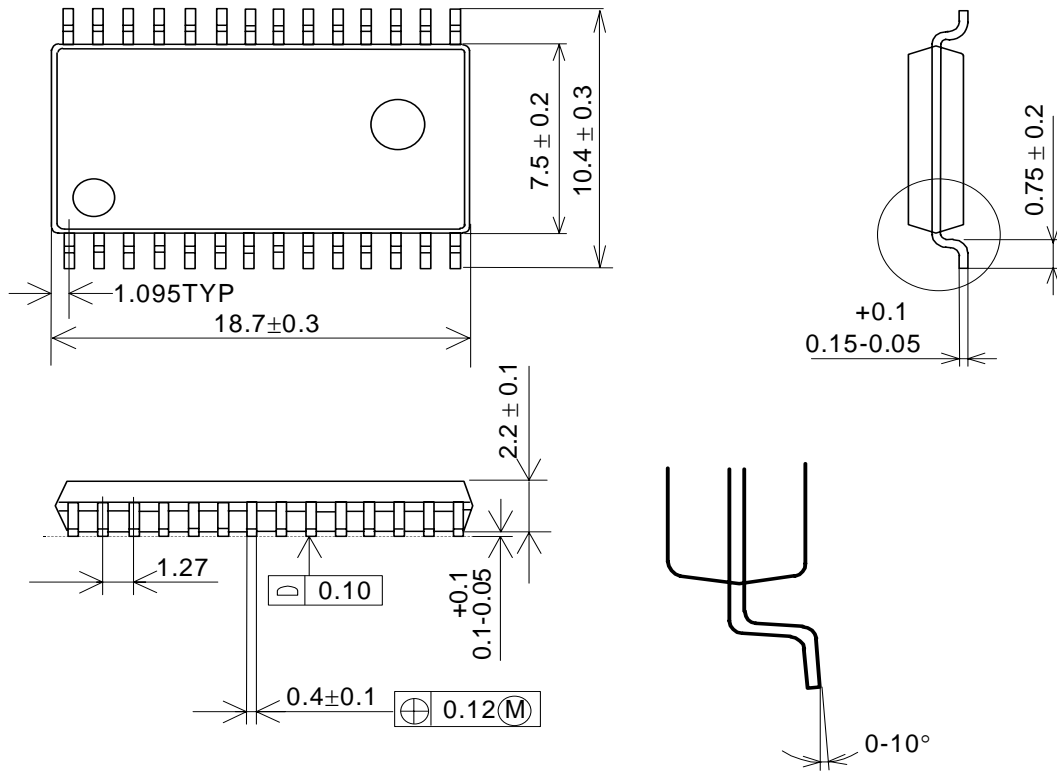

■ Material & Lead finish

Package molding compound:	Epoxy
Lead frame material:	Cu
Lead frame surface treatment:	Solder (Pb free) plate

MARKING (AK5385BVF)

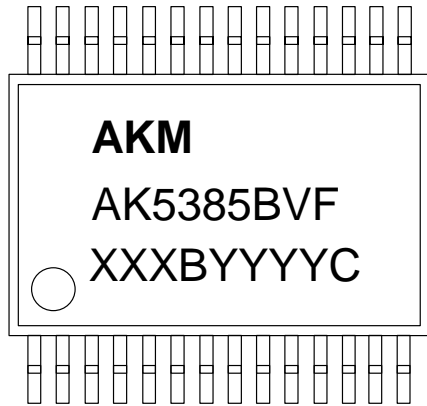

XXXBYYYYC Date code identifier

XXXB :Lot number (X : Digit number, B : Alpha character)
YYYYC : Assembly date (Y : Digit number, C : Alpha character)

MARKING (AK5385BVS)

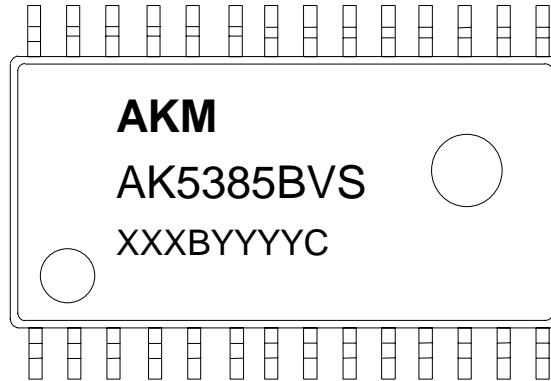

XXXBYYYYC Date code identifier

XXXB :Lot number (X : Digit number, B : Alpha character)
 YYYYYC : Assembly date (Y : Digit number, C : Alpha character)

Revision History

Date (YY/MM/DD)	Revision	Reason	Page	Contents
05/08/10	00	First Edition		

IMPORTANT NOTICE

- These products and their specifications are subject to change without notice. Before considering any use or application, consult the Asahi Kasei Microsystems Co., Ltd. (AKM) sales office or authorized distributor concerning their current status.
- AKM assumes no liability for infringement of any patent, intellectual property, or other right in the application or use of any information contained herein.
- Any export of these products, or devices or systems containing them, may require an export license or other official approval under the law and regulations of the country of export pertaining to customs and tariffs, currency exchange, or strategic materials.
- AKM products are neither intended nor authorized for use as critical components in any safety, life support, or other hazard related device or system, and AKM assumes no responsibility relating to any such use, except with the express written consent of the Representative Director of AKM. As used here:
 - a. A hazard related device or system is one designed or intended for life support or maintenance of safety or for applications in medicine, aerospace, nuclear energy, or other fields, in which its failure to function or perform may reasonably be expected to result in loss of life or in significant injury or damage to person or property.
 - b. A critical component is one whose failure to function or perform may reasonably be expected to result, whether directly or indirectly, in the loss of the safety or effectiveness of the device or system containing it, and which must therefore meet very high standards of performance and reliability.
- It is the responsibility of the buyer or distributor of an AKM product who distributes, disposes of, or otherwise places the product with a third party to notify that party in advance of the above content and conditions, and the buyer or distributor agrees to assume any and all responsibility and liability for and hold AKM harmless from any and all claims arising from the use of said product in the absence of such notification.