

FLAT-PAK™ SERIES Models FP-NML2V & FP-NML2VP Network to Mic/Line Interface with VCA



- Adapts Standard Audio Amplifiers to a Dante Network
- Converts Two Dante Network Audio Signals to Professional Line Level
- Separate VCA Provided for Each Output
- Outputs are Adjustable using RDL or OEM Remote Controls or 0 to 10 Vdc
- Individually Adjustable Outputs Ideal to Feed Two Separate Amplifiers
- Each Output is Switch-Selectable for Mic or Line Level
- Line-Level Outputs Provide +4 dBu with VCA at Maximum
- Output Amplifiers Provide More than 18 dB Headroom
- Exceptional Low-Noise and Low-Distortion Performance
- Crosstalk is Below the Noise Floor
- 24 Vdc Pass-Through Jack for Power Supply Sharing with RDL Amplifiers (FP-NML2V)
- High Resolution 24 Bit Digital to Analog Conversion
- Legendary RDL Analog Filtering Enhances Superb Audio Performance
- Outputs Mute when Digital Audio Inputs are Inactive
- Normal or Hot-Standby Operation from PoE (Model FP-NML2VP)
- Equipped for Rack Mounting or Surface Mounting

The FP-NML2V modules are Dante audio network interface products compatible with mic-level or line-level audio equipment inputs. These modules are designed to be mounted in equipment racks, closets, conference tables and on shelves or backboards in commercial/industrial installations.

APPLICATION: The FP-NML2V is a high quality converter that provides professional line-level outputs from two Dante network audio channels. Each un-attenuated line output provides +4 dBu balanced for a network digital audio level of -18 dBFS. The professional output directly interfaces with other professional and commercial equipment without the need for additional gain. Crosstalk is below the noise floor between all outputs across the entire audio spectrum. The noise floor is better than 80 dB below operating level with greater than 18 dB of headroom. Each output is equipped with a recessed mic/line switch that provides 50 dB of attenuation to feed the microphone input of a mixer-amplifier or other equipment with mic inputs.

Each output is equipped with a VCA circuit for remotely adjusting the output level. Separate remote controls may be used for each output, or a single remote control may be connected to adjust both outputs simultaneously. VCA control uses industry standard 0 to 10 Volts allowing audio levels to be adjusted using a wide variety of industry equipment. RDL offers a range of compatible passive and multi-point rotary-encoder remote controls with and without muting options.

The FP-NML2V is powered from an external 24 Vdc power supply, available separately. The FP-NML2VP is equipped to operate from a PoE enabled network switch. The FP-NML2VP will reserve power from the switch even while being powered from an external 24 Vdc supply. If PoE power and an external 24 Vdc supply are both feeding an FP-NML2VP, the unit will run from the external supply and will seamlessly switch over to PoE power upon loss of the external supply.

The FP-NML2V includes a dc output jack and extension cable that allows it to be operated from a common power supply with RDL FLAT-PAK amplifiers. One audio output connects to the FLAT-PAK amplifier input, and the second output may be connected to an additional amplifier.

The FP-NML2V's superior performance specifications make it ideally suited to the most demanding installations, and an exceptional value in commercial networked audio systems.

The FP-NML2V is constructed in a durable, professional all-metal enclosure suitable for free-standing, surface-mounted or rack-mounted operation. This full-featured product is engineered and manufactured in the U.S.A for continuous duty in demanding installations. Built to last. Built to outperform.

FLAT-PAK™ SERIES Models FP-NML2V & FP-NML2VP Network to Mic/Line Interface with VCA

Installation/Operation

Declaration of Conformity available from rdlnet.com.
Sole EMC specifications provided on product package.
Specifications are subject to change without notice.

Network and Power Connections

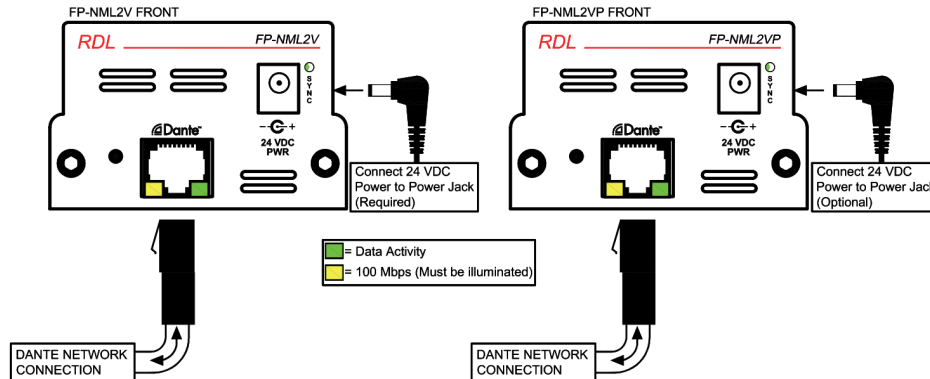

Audio and Power Bus Connections

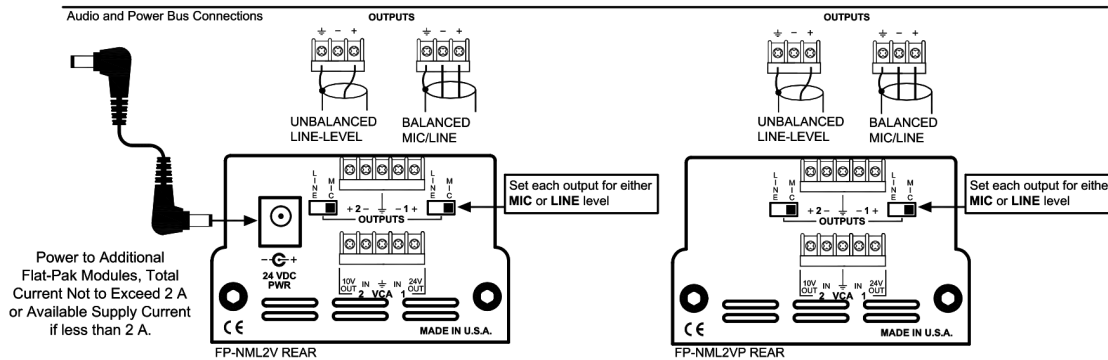

VCA Control Connections

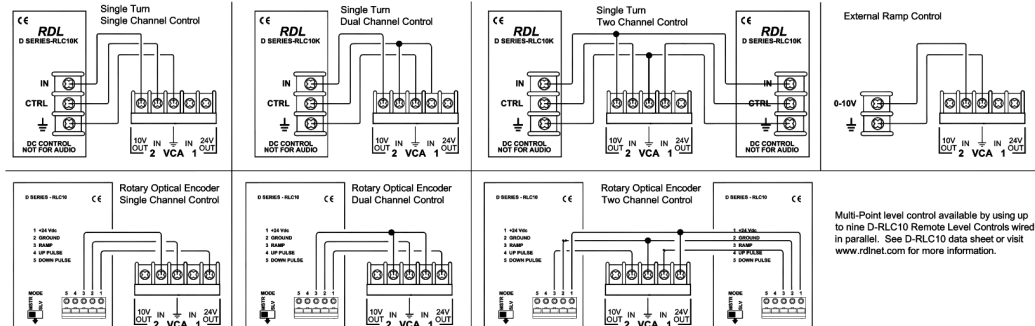

TYPICAL PERFORMANCE

Network Connector: RJ45 with Link and Speed indicators
Digital Audio Ethernet Protocol: Dante
Transmission Rate: 100 Mbps
Sample Rates Supported: 44.1 kHz, 48 kHz (default)
Bit Depth Supported: 24 bits
Audio Operating Levels: -20 dBFS = +4 dBu

Outputs (2): Balanced, detachable terminal block
Output Level: +4 dBu (nominal)
Output Impedance: 150 Ω balanced; 75 Ω unbalanced
VCA Control: 0 to 10 Vdc or 0 to 10 kΩ
VCA Attenuation: 0 to > 90 dB, Audio taper
Frequency Response: 20 Hz to 20 kHz (± 0.5 dB)
THD+N: < 0.1%

Noise below +4 dBu: < -80 dB (output active); < -95 dB (outputs muted)
Crosstalk: < 90 dB (1 kHz); < 80 dB (20 to 20 kHz)
Headroom above +4 dBu: > 18 dB
Indicators (3): Ethernet Link and Speed, SYNC
Power Connections (1): Power Jack
Ambient Operating Environment: 0° C to 40° C
Power Requirement: 24 Vdc @ 135 mA, or PoE (FP-NML2VP)
PoE (FP-NML2VP): Class 0, IEEE 802.3af
Dimensions: 4.85" (12.3 cm) W; 1.75" (4.45 cm) H; 3.25" (8.26 cm) D
Package Type: Cardboard Box
Package Dimensions: 4.375 x 4.8 x 2.25 in.
Shipping Weight: 0.828 lbs. (FP-NML2V); 0.857 (FP-NML2VP)
WEEE weight: 0.682 lbs. (FP-NML2V); 0.711 (FP-NML2VP)
Tariff code: 8517.18.0050

