

Model AV-XMN4 Microphone to Network Interface

- Dante Network Interface for Four Audio Mic Inputs
- Each XLR Input Provides Switch-Selectable Mic Gain: 40 dB, 48 dB or 62 dB
- 48 V Mic Phantom (P48) on each input
- Four XLR Front-Panel Inputs
- Converts Four Standard XLR Mic Sources to Dante Network Channels
- Special Software Not Required for Module Setup
- High Resolution 24 Bit Analog to Digital Conversion
- LED Indicator for Valid Power and Network Sync
- Operation from PoE Power (Class 0, IEEE 802.3af) or external 24 Vdc
- Mounts on a Microphone Stand using an RDL SF-MSM1



AV-PAK products are heavy duty modules intended for rugged field use. Functions include interface, isolation, ground-lift and signal dividing/combining and amplification. AV-PAKs are engineered to provide higher performance and better shielding than other industry products. Standard connector types are provided for direct connection and operation by end users. The heavy duty extruded aluminum and steel chassis are finished in a high quality powder coat. The heavy chassis and dark color style make AV-PAKs ideal for both stage use and permanent installation. AV-PAK modules are designed and manufactured in the U.S.A.

APPLICATION: The AV-XMN4 is an interface that converts four XLR microphone inputs to Dante network audio channels. Special software is not required to configure the AV-XMN4. Each XLR input is equipped with a switch to set the gain for dynamic or condenser microphones. A dual-LED VU meter displays the level for each input to facilitate selection of the ideal gain range. P48 phantom voltage is supplied to each microphone input. The AV-XMN4 is a professional grade product with discrete mic preamplifiers for studio quality fidelity and low noise performance.

The AV-XMN4 may be powered from an external 24 Vdc power supply, available separately. The AV-XMN4 is equipped to operate from a PoE enabled network switch. The AV-XMN4 will reserve power from the switch even while being powered from an external 24 Vdc supply. If PoE power and an external 24 Vdc supply are both feeding an AV-XMN4, the unit will run from the external supply and will seamlessly switch over to PoE power upon loss of the external supply. Valid power and synchronization to the Dante network is indicated by a green LED visible from the front of the unit.

The AV-XMN4 is constructed in a durable, professional all-metal enclosure suitable for use on stage or in studio, or mounted to any flat surface. For fixed installations, mounting brackets are included. The chassis is designed to protect the front panel slide switches from accidental damage. This full-featured AV-PAK product is engineered and manufactured in the U.S.A for continuous duty in demanding installations.

Model AV-XMN4 Microphone to Network Interface

Installation/Operation

CE Declaration of Conformity available from rdlnet.com.
Sole EMC specifications provided on product package.
Specifications are subject to change without notice.

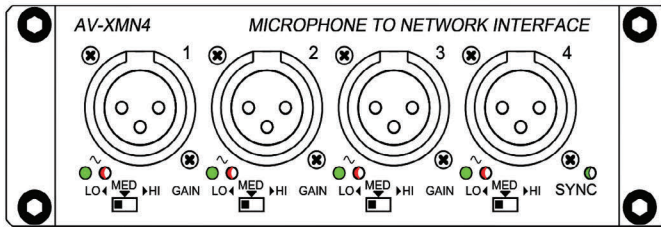

USE GAIN SWITCH TO SELECT CORRECT LEVEL FOR DYNAMIC OR CONDENSER MICROPHONES

DUAL-LED VU METER DISPLAYS THE LEVEL TO FACILITATE SELECTION OF IDEAL GAIN RANGE

WHILE SPEAKING INTO THE MICROPHONE SET THE GAIN SWITCH FOR MAXIMUM BRIGHTNESS OF THE GREEN (NORMAL) LED WITH OCCASIONAL FLASHES OF THE RED (PEAK) LED

SYNC INDICATES VALID POE POWER AND SYNCHRONIZATION TO A MASTER CLOCK. THE MASTER CLOCK MAY ORIGINATE IN THIS MODULE OR OTHER DANTE DEVICE ON THE NETWORK. (GREEN)

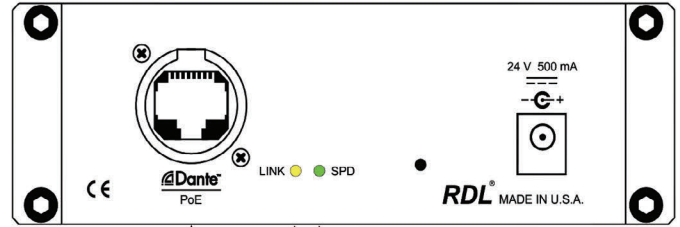

100 Mbps LED (Green)
-Must be illuminated-

Data Activity LED (Yellow)

DANTE NETWORK CONNECTION

- 1) Place the two included mounting brackets on either side of the unit as shown.
- 2) Secure the brackets to the mounting surface with four user provided screws.

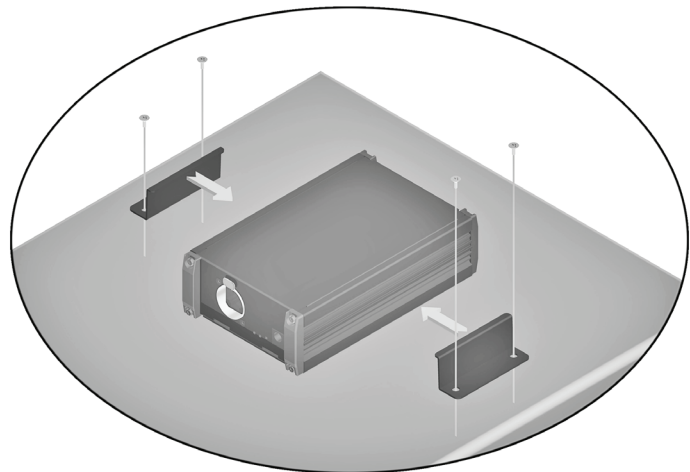

TYPICAL PERFORMANCE

Network Connector:	RJ45 Neutrik® etherCON®
Digital Audio Ethernet Protocol:	Dante
Transmission Rate:	100 Mbps
Sample Rates Supported:	44.1 kHz, 48 kHz (default), 88.2 kHz, 96 kHz
Bit Depth Supported:	24 bits
Audio Operating Level:	-20 dBFS = +4 dBu
Reference Level:	0 dBFS = +24 dBu
Inputs (4):	XLR (female)
Gain:	Mic: 40 dB (LO), 48 dB (MED), 62 dB (HI); front-panel selectable
Input Level (for +4 dBu/-20 dBFS):	Mic: -36 dBu (LO), -44 dBu (MED), -58 dBu (HI)
Input Level (maximum):	Mic: -16 dBu (LO), -24 dBu (MED), -38 dBu (HI)
Input Impedance:	> 2.5 kΩ
Phantom Power:	P48, 48 Vdc
Standard for Phantom:	IEC 61938: 2013
Frequency Response:	20 Hz to 20 kHz (± 0.5 dB)
Equivalent Input Noise:	-130 dBu (62 dB gain); -132 dBu A-Weighted
Noise below -20 dBFS (20 to 20 kHz):	Mic: < -72 dB (LO), < -72 dB (MED), < -68 dB (HI)
THD+N:	< 0.1% (20 Hz to 20 kHz, +4 dBu/-20 dBFS); 0.015% at 1 kHz (typ)

CMRR:	> 65 dB (50 Hz to 120 Hz)
Crosstalk:	Below Noise Floor (20 Hz to 20 kHz at operating level, any input to any input, max. mic gain)
Indicators (11):	Ethernet Link and Speed (2, rear panel); Sync (front panel); dual-LED VU meter (8 LED, front panel)
Ambient Operating Environment:	0° C to 50° C
Power Requirement:	PoE Class 0, IEEE 802.3af
Specification Conditions:	Gain/Level: ± 1 dB; Source termination: 150 Ω; A to D values measured in digital domain

Dimensions:	5.19" (13.18 cm) W; 1.68" (4.27 cm) H; 5.97" (15.16 cm) D
Package Type:	Cardboard Box
Package Dimensions:	6 x 6 x 2.625 in.
Shipping Weight:	1.79 lbs.
WEEE weight:	1.56 lbs.
Tariff code:	8517.18.0050

