

Model SF-NP50A Network to 50 W Mono Audio Amplifier - 70 V or 100 V

- 50 Watts RMS Constant Voltage Amplifier
- 70 V or 100 V Output
- Plenum Rated per UL 2043 Standard
- Converts One Dante Network Audio Signal to a Mono Constant Voltage Output
- Selectable Dante Sample Rates: 44.1 kHz, 48 kHz, 88.2 kHz, 96 kHz
- 0 dBFS Input for 50 W Output
- Analog Balanced Mono Input or Unbalanced Stereo Mini-Jack Input
- Automatic Ducking Controlled by Network or Analog Input (Switch-Selectable)
- Ducking Attenuation -25 dB or "off" (Switch-Selectable)
- Balanced Line Output from Network Audio Source
- Automatically Limits Supply Current to Protect Against Power Supply Shutdown
- VCA Control on Detachable Terminal Block
- External Control Using 10 k Ω Potentiometer or 0 to 10 Vdc
- Compatible with RDL Remote Level Controls
- Special Software Not Required for Module Setup
- LED Indicators: Network Sync, Amplifier Mute, Analog Input Level, Ducking Threshold
- High-Efficiency Class D Operation
- Thermal and Short-Circuit Protection



The SysFlex® series is a family of A/V modules providing complex interface solutions at the click of a connector. Certain SysFlex modules provide connectorized interface between data networks and analog and digital audio devices. Other SysFlex modules include networked and conventional amplifiers and other application-specific solutions. In RDL's tradition of versatility, SysFlex modules can be used right where they are needed: Rack-mounted, Surface-mounted, or unmounted. They are light-weight, compact and easy to install with simple, straightforward switch settings and LED indicators. Modules quickly snap into the SysFlex rack mount and each is firmly secured with a single screw. The racking system segregates network and power wiring from the audio and digital audio connectors. For connectorized network audio endpoints and A/V system components that provide unparalleled performance and advanced features without giving up simplicity and ease of installation, SysFlex is the industry's best value.

APPLICATION: The SF-NP50A is an audio power amplifier that converts one Dante network audio channel and one analog input to a 70 V or 100 V constant voltage amplified output. The output provides 50 watts for a network digital audio level of 0 dBFS. Special software is not required to configure the module.

An analog audio source may be connected to either the mono balanced terminal block input or to the unbalanced Mini-Jack which sums the left and right channels to mono. Input gain is set by the installer using a rear-panel single-turn potentiometer with an associated dual-LED VU meter calibrated to 20 dB below maximum power output.

Either the analog input or the network audio input may be used as a paging source. A rear-panel switch is used to set which input has priority. That input utilizes an automatic detection circuit with an adjustable threshold indicated by an LED to attenuate by 25 dB or mute OFF the other input as set by a rear-panel switch. The attenuated input fades up to normal volume when the paging message is finished.

The Dante network audio source drives a balanced line-level output on a detachable terminal block to feed the inputs of other audio equipment or power amplifiers. The output level is +4 dBu balanced for a network level of -20 dBFS.

The SF-NP50A is equipped with an internal VCA for setting the amplifier output level. A detachable terminal block provides for the connection of an external 10 k Ω potentiometer or a 0 to 10 Vdc control voltage. RDL remote controls are available to provide single-turn, multi-turn (rotary encoder) or pushbutton (ramp or fixed level selection) user level control. VCA control insures long term noise-free level adjustment.

The module is equipped with both thermal and output short-circuit protection. The high-efficiency Class D output stage produces minimal heat for all levels of expected voice or music modulation. Upon power-up and during overloads or overheating, an LED MUTE indicator glows yellow and the output is muted. Valid synchronization to the Dante network is indicated by a green LED visible from the front of the unit.

The SF-NP50A is equipped to operate from an included external 24 Vdc power supply. The SF-NP50A monitors the amplifier power and limits the current to protect the power supply from shutting down even during extreme feedback or square wave modulation conditions. A red rear-panel OVERLOAD PROTECT LED flashes when the SF-NP50A reduces power consumption to prevent shutdown of the power supply.

The SF-NP50A is constructed in a durable, professional all-metal enclosure suitable for free-standing, surface-mounted or rack-mounted operation. This full-featured SYSFLEX product is engineered and manufactured in the U.S.A for continuous duty in demanding installations. The versatility of SYSFLEX products adds enormous flexibility in the design and installation of professional A/V systems.

Model SF-NP50A Network to 50 W Mono Audio Amplifier - 70 V or 100 V

Installation/Operation

CE Declaration of Conformity available from rdlnet.com.
Sole EMC specifications provided on product package.
Specifications are subject to change without notice.

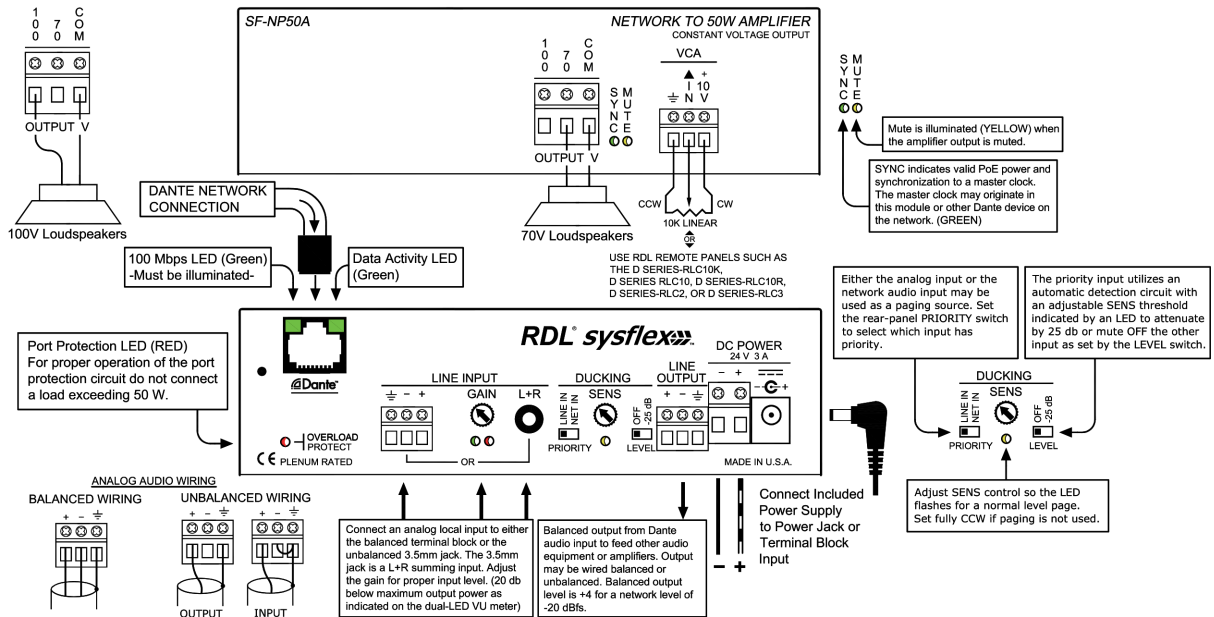

To install the amplifier to 1/4" - 20 all-thread install the mounting tab to the bottom of the unit with the included screw. (Position the concave side toward the bottom of the unit.) Attach the all-thread through the large hole in the mounting tab and another piece in the mounting hole in the chassis flange. Secure with nuts. (All-thread and nuts not included)

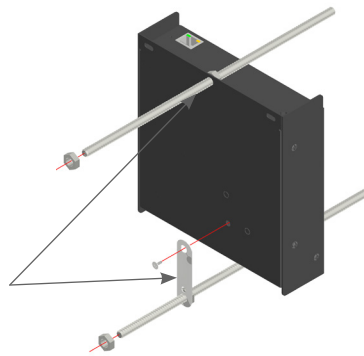

Cut outs and mounting tab may be used to suspend the unit above the ceiling using hanger wire.

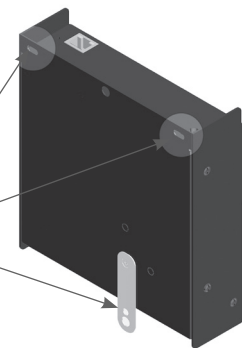

TYPICAL PERFORMANCE

Inputs (2): <u>Network Input Section</u> Network Connector: Digital Audio Ethernet Protocol: Transmission Rate: Sample Rates Supported: Bit Depth Supported: <u>Analog Section</u> Analog Input Connectors (2):	Dante network (1 channel), Analog audio RJ45 with Link and Speed indicators Dante 100 Mbps 44.1 kHz, 48 kHz (default), 88.2 kHz, 96 kHz 24 bits Balanced on terminal block or stereo unbalanced Mini-Jack (L and R inputs summed to mono) +4 dBu nominal, adjustable; -10 dBu minimum (for 20 dB below full output power); +25 dBu maximum (before clipping) -10 dBV nominal, adjustable; -25 dBV minimum (for 20 dB below full output power); +10 dBV maximum (before clipping) Single turn audio taper (with associated Dual-LED VU Meter calibrated to 20 dB below full output power) >10 kΩ balanced, >5 kΩ unbalanced > 60 dB (50 Hz à 120 Hz) Automatic (Rear-panel adjustable signal threshold with LED indicator) 4 seconds, nominal Switch-selectable priority for network or analog input Switch-selectable for 25 dB ducking attenuation (nominal) or OFF
Balanced Input Level:	
Unbalanced Input Level:	
Gain Adjustment:	
Input Impedance: Common mode rejection: Ducking/Muting Actuation: Ducking/Muting Release Delay: Ducking/Muting Source: Ducking/Muting Level:	

Reference Level (network input): Power Amplifier Output: Frequency Response: THD +N: Noise:	0 dBFS = 50 W 50 W RMS (70 or 100 V) +0/-3 dB (50 Hz to 20 kHz) < 1% (1 kHz) <-85 dB (below max power); <-75 dB (below 1/8 power)
Line Output: Frequency Response: Noise:	+4 dBu balanced (for -20 dBFS) +/- 0.6 dB (20 Hz to 10 kHz); +/- 2 dB (20 Hz to 20 kHz) <-70 dB (below +4 dBu)
Indicators (8):	Front-panel: Sync (green), Amplifier muted (yel), Rear-panel: Overload Protect (red), Ethernet Link and Speed (2), dual-LED VU meter (2), Ducking threshold 0 to 10 Vdc control, detachable terminal block (compatible with RDL VCA wall controls)
VCA:	
Ambient Operating Environment: Power Requirement: Power Supply (included): Plenum Rating Standard: Package Type: Package Dimensions: Shipping Weight: WEEE weight: Tariff code:	0° C to 40° C Maximum; 20° C Recommended 24 Vdc @ 2700 mA 100 to 240 Vac, 50-60 Hz, IEC C14; Output to module: 24 Vdc UL 2043 Cardboard Box 10 x 7 x 2.25 in. 4.22 lbs. 3.82 lbs. 8518.50.0000

