

Model SF-PA50A 50 W Mono Audio Amplifier - 70 V or 100 V

- 50 Watts RMS Constant Voltage Amplifier
- 70 V or 100 V Output
- Plenum Rated per UL 2043 Standard
- Analog Balanced Mono Input or Unbalanced Stereo Mini-Jack Input
- Adjustable Gain with Dual-LED VU Metering
- Automatically Limits Supply Current to Protect Against Power Supply Shutdown
- VCA Control on Detachable Terminal Block
- External Control Using 10 kΩ Potentiometer or 0 to 10 Vdc
- Compatible with RDL Remote Level Controls
- LED Indicators: Power, Amplifier Mute, Analog Input Level
- High-Efficiency Class D Operation
- Thermal and Short-Circuit Protection



The SysFlex® series is a family of A/V modules providing complex interface solutions at the click of a connector. Certain SysFlex modules provide connectorized interface between data networks and analog and digital audio devices. Other SysFlex modules include networked and conventional amplifiers and other application-specific solutions. In RDL's tradition of versatility, SysFlex modules can be used right where they are needed: Rack-mounted, Surface-mounted, or unmounted. They are light-weight, compact and easy to install with simple, straightforward switch settings and LED indicators. Modules quickly snap into the SysFlex rack mount and each is firmly secured with a single screw. The racking system segregates network and power wiring from the audio and digital audio connectors. For connectorized network audio endpoints and A/V system components that provide unparalleled performance and advanced features without giving up simplicity and ease of installation, SysFlex is the industry's best value.

APPLICATION: The SF-PA50A is a 50 Watt audio power amplifier that converts one analog input to a 70 V or 100 V constant voltage amplified output.

An analog audio source may be connected to either the mono balanced terminal block input or to the unbalanced Mini-Jack which sums the left and right channels to mono. Amplifier gain is set by the installer using a rear-panel single-turn potentiometer with an associated dual-LED VU meter calibrated to 20 dB below maximum power output.

The SF-PA50A is equipped with an internal VCA for setting the amplifier output level. A detachable terminal block provides for the connection of an external 10 kΩ potentiometer or a 0 to 10 Vdc control voltage. RDL remote controls are available to provide single-turn, multi-turn (rotary encoder) or pushbutton (ramp or fixed level selection) user level control. VCA control insures long term noise-free level adjustment.

The module is equipped with both thermal and output short-circuit protection. The high-efficiency Class D output stage produces minimal heat for all levels of expected voice or music modulation. Upon power-up and during overloads or overheating, an LED MUTE indicator glows yellow and the output is muted.

The SF-PA50A is equipped to operate from an included external 24 Vdc power supply. The SF-PA50A monitors the amplifier power and limits the current to protect the power supply from shutting down even during extreme feedback or square wave modulation conditions. A red rear-panel OVERLOAD PROTECT LED flashes when the SF-PA50A reduces power consumption to prevent shutdown of the power supply.

The SF-PA50A is constructed in a durable, professional all-metal enclosure suitable for free-standing, surface-mounted or rack-mounted operation. This full-featured SYSFLEX product is engineered and manufactured in the U.S.A for continuous duty in demanding installations. The versatility of SYSFLEX products adds enormous flexibility in the design and installation of professional A/V systems.

Model SF-PA50A 50 W Mono Audio Amplifier - 70 V or 100 V

Installation/Operation

CE Declaration of Conformity available from rdlnet.com.
Sole EMC specifications provided on product package.
Specifications are subject to change without notice.

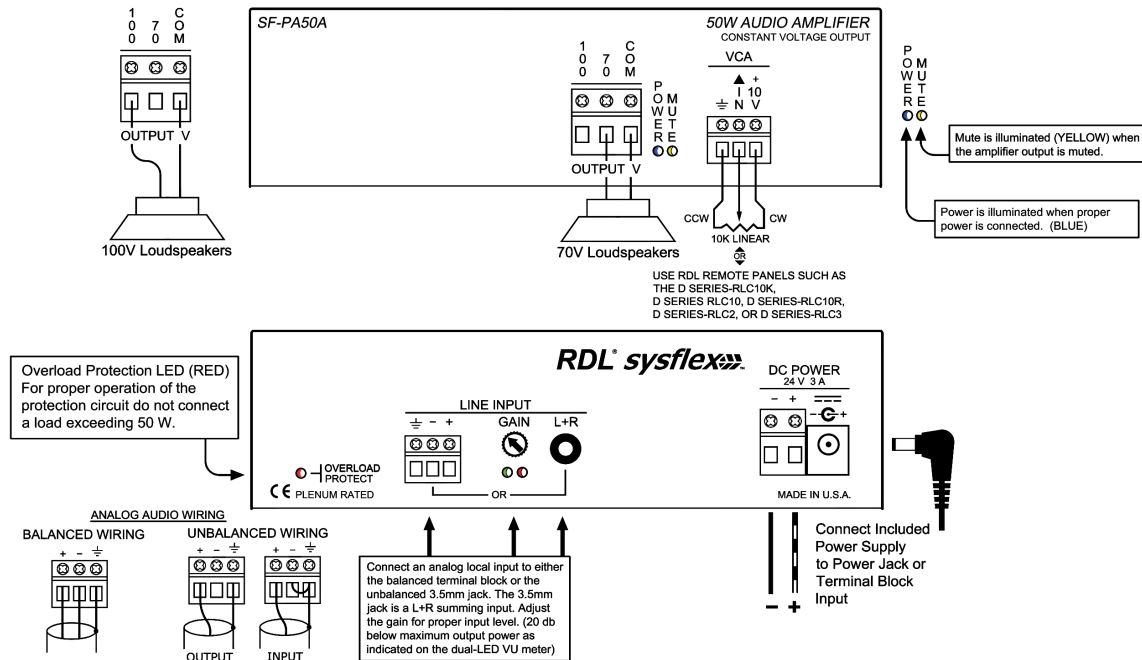

To install the amplifier to 1/4" - 20 all-thread install the mounting tab to the bottom of the unit with the included screw. (Position the concave side toward the bottom of the unit.) Attach the all-thread through the large hole in the mounting tab and another piece in the mounting hole in the chassis flange. Secure with nuts. (All-thread and nuts not included)

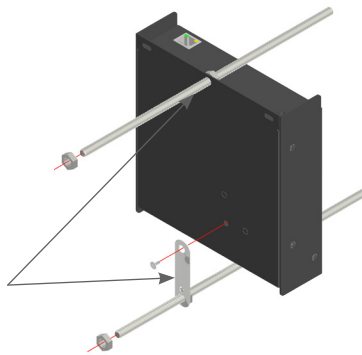

Cut outs and mounting tab may be used to suspend the unit above the ceiling using hanger wire.

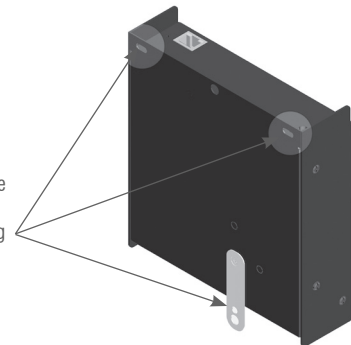

TYPICAL PERFORMANCE

Analog Input Connectors (2):	Balanced terminal block or stereo unbalanced Mini-Jack (L and R inputs summed to mono)	VCA:	0 to 10 Vdc control, detachable terminal block (compatible with RDL VCA wall controls)
Balanced Input Level:	+4 dBu nominal, adjustable; -10 dBu minimum (for 20 dB below full output power); +25 dBu maximum (before clipping)	Ambient Operating Environment:	0° C to 40° C Maximum; 20° C Recommended
Unbalanced Input Level:	-10 dBV nominal, adjustable; -25 dBV minimum (for 20 dB below full output power); +10 dBV maximum (before clipping)	Power Requirement:	24 Vdc @ 2700 mA
Gain Adjustment:	Single turn audio taper (with associated Dual-LED VU meter calibrated to 20 dB below full output power)	Power Supply (included):	100 to 240 Vac, 50-60 Hz, IEC C14; Output to module: 24 Vdc
Input Impedance:	>10 kΩ balanced, >5 kΩ unbalanced	Plenum Rating Standard:	UL 2043
Common mode rejection:	> 60 dB (balanced, 50 Hz to 120 Hz)	Dimensions:	Height: 1.7 in. (4,32 cm); Width: 5.83 in. (14,8 cm); Depth: 6.45 in. (16,38 cm)
Power Amplifier Output:	50 W RMS (70 or 100 V)	Package Type:	Cardboard Box
Frequency Response:	+0/-3 dB (50 Hz to 20 kHz)	Package Dimensions:	10 x 7 x 2.25 in.
THD+N:	< 1% (1 kHz)	Shipping Weight:	4.22 lbs.
Noise:	< -90 dB (below max power); < -80 dB (below 1/8 power)	WEEE weight:	3.82 lbs.
Indicators (5):	Front-panel: Power (blue), Amplifier muted (yel), Rear-panel: Overload Protect (red), dual-LED VU meter (2)	Tariff code:	8518.50.0000

