



RDL[®]

Radio Design Labs

SPECIALISTS IN PRACTICAL PRECISION ENGINEERING™

RACK-UP[®] SERIES Model RU-SM16A Dual Audio Meter

- Precision Audio Level Metering
- Digital 16 LED String Display Indication
- Two Mono Meters or Stereo Metering
- Selectable Fixed or Variable Calibration
- Individual Channel Calibration Controls
- Selectable Peak or Average Metering
- Peak-Hold Display for +10, +14, +18 dB
- Line-Level, Speaker-Level or 25/70/100 V Audio Input



The RU-SM16A is part of the group of RACK-UP products from Radio Design Labs. RACK-UPs feature the advanced circuitry for which RDL products are known, combined with accessible user-friendly controls and displays. The ultra compact design permits high-density installations, with *three* products mounted in a single rack unit! Single RACK-UPs can be mounted right where they are needed using the adhesive method popularized by RDL's STICK-ON[®] series of products. Optional brackets permit mounting a RACK-UP module above, below, or in front of any flat surface!

APPLICATION: The RU-SM16A is a two channel audio meter that measures and displays line-level audio, constant voltage or low impedance amplified audio level. Each meter provides either fixed or variable calibration and displays in either peak or VU style average mode.

Each input accepts balanced or unbalanced line-level audio, or amplified audio from a low impedance (4 Ohm or 8 Ohm) or constant voltage (25 V, 70 V, or 100V) power amplifier. Rear-panel input range switches match the meter gain and calibration to the input source. Inputs are connected through a detachable terminal block.

A rear-panel switch sets the input calibration to FIXED or VARIABLE. In the FIXED setting, 0 dB on the meter corresponds to the input range switch setting of +4 dBu, 25 V, 70 V or 100 V. In the VARIABLE position, the front-panel trimmers are active, permitting the 0 dB meter LED to be calibrated to average signal levels as much as 20 dB below the FIXED calibrated value.

Each meter ballistic is set using a rear-panel switch. In the PEAK setting, the meter responds to audio peak content. In the AVERAGE position, the meter displays the average audio level following VU time constants. In either mode the upper three LEDs (+10, +14, +18) remain in the PEAK HOLD mode.

In mono installations, it may be advantageous to feed the mono source to both meters, setting one for peak and the other for average. When monitoring constant voltage installations, one meter may be fed directly from the output of the amplifier while the other meter is fed from a return cable at the end of the speaker line run. This provides an instant visual verification of continuity through the public address system.

The flexible range of input signals, vibrant visibility, professional appearance, accuracy and mounting possibilities of the RU-SM16A make it ideally suited to commercial, professional, studio and broadcast applications. Combine the RU-SM16A with other RDL products as part of an integrated, high quality system.



RDL[®]
Radio Design Labs

SPECIALISTS IN PRACTICAL PRECISION ENGINEERING™



RACK-UP® SERIES Model RU-SM16A Dual Audio Meter

Installation/Operation



Declaration of Conformity available from rdlnet.com.
Sole EMC specifications provided on product package.
Specifications are subject to change without notice.

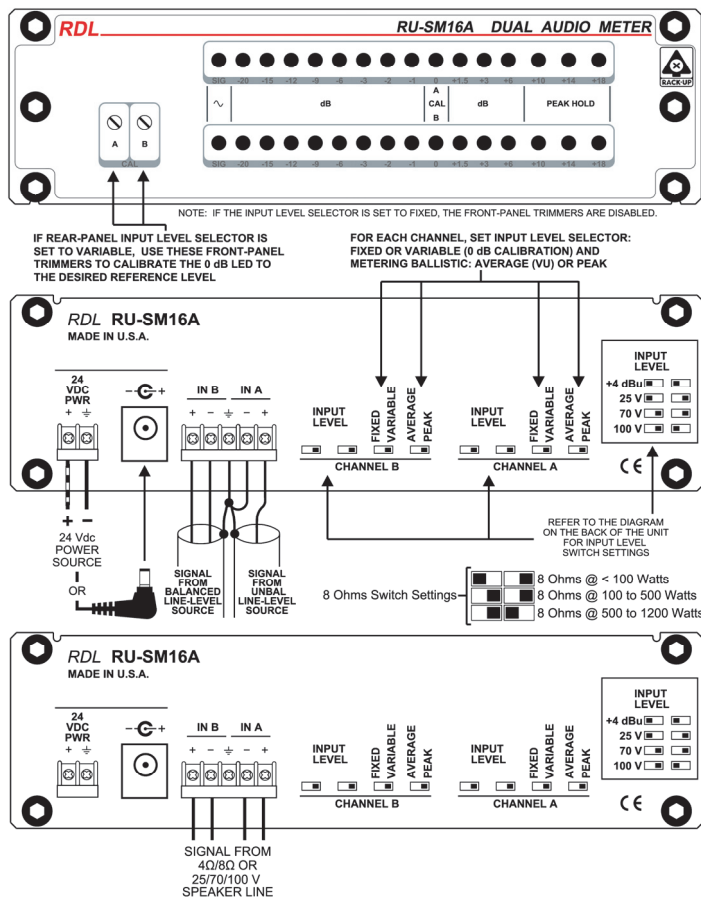

TYPICAL PERFORMANCE

Inputs (2):	Line level or Amplified speaker level
Input Impedance:	> 40 kΩ balanced or unbalanced
0 dB Calibration:	Fixed or Variable (switch-selectable)
Fixed Input Level:	+4 dBu (+4 switch settings, for 0 dB reading) 25 V* (25 V switch settings, for 0 dB reading) 70 V* (70 V switch settings, for 0 dB reading) 100 V* (100 V switch settings, for 0 dB reading)
Variable Input Level Range:	-24 dBu to +12 dBu (+4 switch settings, for 0 dB reading) 2 V to 90 V* (25 V switch settings, for 0 dB reading) 4 V to 90 V* (70 V switch settings, for 0 dB reading) 5 V to 100 V* (100 V switch settings, for 0 dB reading) *Constant-voltage or low-impedance (4 Ohms, 8 Ohms) amplifier output
Metering Freq. Response:	20 Hz to 20 kHz
Indicators:	16 LEDs per channel; SIG, -20, -15, -12, -9, -6, -3, -2, -1, 0, +1.5, +3, +6, +10, +14, +18 (+10, +14, +18 are PEAK HOLD indicators only)
Metering Response:	Each channel individually selectable PEAK or AVG (switch-selectable)
	Peak Mode Average Mode
Rise Time (10% - 90%)	50 us 130 ms
Rise Time (0% - 100%)	60 us 300 ms**
Fall Time (90% - 10%)	65 ms 185 ms
Fall Time (100% - 0%)	100 ms 300 ms**
	**VU Characteristic
Power Requirement:	GROUND-REFERENCED, 24 Vdc @ 250 mA
Ambient Operating Environment:	0° C to 50° C @ 24 Vdc @ 45 mA, Ground-referenced

