

RACK-UP® SERIES Model RU-SM16D Quad Audio Meter

- Precision Audio Level Metering
- Digital 16 LED String Display Indication
- Four Mono Meters or Dual Stereo Metering
- Selectable Fixed or Variable Calibration
- Individual Channel Calibration Controls
- Selectable Peak or Average Metering
- Peak-Hold Display for +10, +14, +18 dB
- Line-Level, Speaker-Level or 25V/70V/100 V Audio Input



The RU-SM16D is part of the group of RACK-UP products from Radio Design Labs. RACK-UPS feature the advanced circuitry for which RDL products are known, combined with accessible user-friendly controls and displays. The ultra compact design permits high-density installations, with *three* products mounted in a single rack unit! Single RACK-UPS can be mounted right where they are needed using the adhesive method popularized by RDL's STICK-ON® series of products. Optional brackets permit mounting a RACK-UP module above, below, or in front of any flat surface!

APPLICATION: The RU-SM16D is a four channel audio meter that measures and displays line-level audio, constant voltage or low impedance amplified audio level. Each meter provides either fixed or variable calibration and displays in either peak or VU style average mode.

Each input accepts balanced or unbalanced line-level audio, or amplified audio from a low impedance (4 Ohm or 8 Ohm) or constant voltage (25 V, 70 V, or 100V) power amplifier. Rear-panel input range switches match the meter gain and calibration to the input source. Inputs are connected through a detachable terminal block.

A rear-panel switch sets the input calibration to FIXED or VARIABLE. In the FIXED setting, 0 dB on the meter corresponds to the input range switch setting of +4 dBu, 25 V, 70 V or 100 V. In the VARIABLE position, the front-panel trimmers are active, permitting the 0 dB meter LED to be calibrated to average signal levels as much as 20 dB below the FIXED calibrated value.

Each meter ballistic is set using a rear-panel switch. In the PEAK setting, the meter responds to audio peak content. In the AVERAGE position, the meter displays the average audio level following VU time constants. In either mode the upper three LEDs (+10, +14, +18) remain in the PEAK HOLD mode.

In mono installations, it may be advantageous to feed the mono source to two meters, setting one for peak and the other for average. In stereo installations, each channel can feed two of the four meters, permitting both peak and average metering of each channel. When monitoring constant voltage installations, one meter may be fed directly from the output of the amplifier while the next meter is fed from a return cable at the end of the speaker line run. This provides an instant visual verification of continuity through two public address systems. Each meter in the RU-SM16D can monitor separate audio sources. With adjacent mounting of three RU-SM16Ds, 12 channels of audio can be precisely monitored in a single rack unit.

The flexible range of input signals, vibrant visibility, professional appearance, accuracy and mounting possibilities of the RU-SM16D make it ideally suited to commercial, professional, studio and broadcast applications. Combine the RU-SM16D with other RDL products as part of an integrated, high quality system.



RDL[®]
Radio Design Labs

SPECIALISTS IN PRACTICAL PRECISION ENGINEERING™



RACK-UP® SERIES Model RU-SM16D Quad Audio Meter

Installation/Operation



Declaration of Conformity available from rdlnet.com.
Sole EMC specifications provided on product package.
Specifications are subject to change without notice.

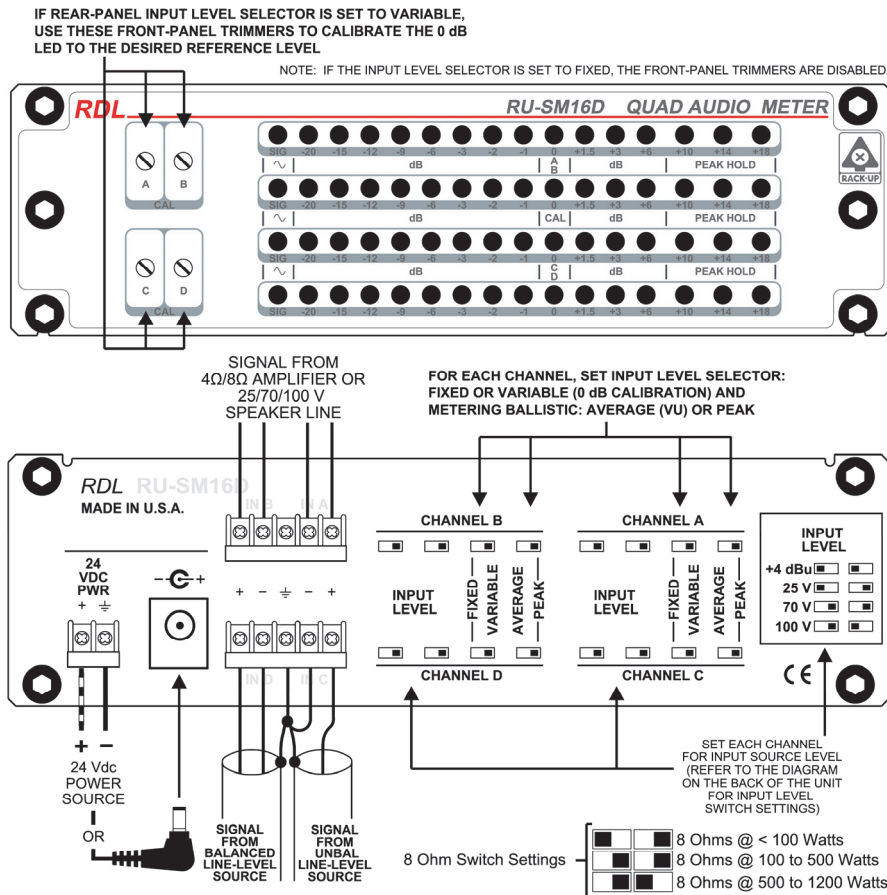

TYPICAL PERFORMANCE

Inputs (4):

Input Impedance:

0 dB Calibration:

Fixed Input Level:

Variable Input Level Range:

Metering Freq. Response:

Indicators:

Metering Response:

Rise Time (10% - 90%)

Rise Time (0% - 100%)

Fall Time (90% - 10%)

Fall Time (100% - 0%)

Line level or Amplified speaker level

> 40 kΩ balanced or unbalanced

Fixed or Variable (switch-selectable)

+4 dBu (+4 switch settings, for 0 dB reading)

25 V* (25 V switch settings, for 0 dB reading)

70 V* (70 V switch settings, for 0 dB reading)

100 V* (100 V switch settings, for 0 dB reading)

-24 dBu to +12 dBu (+4 switch settings, for 0 dB reading)

2 V to 90 V* (25 V switch settings, for 0 dB reading)

4 V to 90 V* (70 V switch settings, for 0 dB reading)

5 V to 100 V* (100 V switch settings, for 0 dB reading)

*Constant-voltage or low-impedance (4 Ohms, 8 Ohms) amplifier output

20 Hz to 20 kHz

16 LEDs per channel; SIG, -20, -15, -12, -9, -6, -3, -2, -1, 0, +1.5, +3, +6, +10, +14, +18

(+10, +14, +18 are PEAK HOLD indicators only)

Each channel individually selectable PEAK or AVG (switch-selectable)

Peak Mode Average Mode

50 us 130 ms

60 us 300 ms**

65 ms 185 ms

100 ms 300 ms**

**VU Characteristic

Power Requirement:

Ambient Operating Environment:

GROUND-REFERENCED, 24 Vdc @ 450 mA

0° C to 40°C @ 45 mA, Ground-referenced



Rhox Áudio e Vídeo Profissional - SIBS Quadra 2 conjunto C Lote 12
Brasília - DF - 71736.203 - Tel (61) 3051-5800

<https://loja.rhox.com.br>

