

RACK-UP® SERIES Model RU-ASX4D Stereo Audio Selector 4x1

- Local or Remote Controlled Switching
- Multiple Switching Control Points
- 4 Stereo Inputs to 1 Stereo Output
- Line-Level Audio Switching
- Balanced or Unbalanced Inputs and Output
- Gain Trim on Each Source
- Open-Collector Output for Selected Input
- Controllable Using Various RDL Remote Controls



The RU-ASX4D is part of the group of RACK-UP products from Radio Design Labs. RACK-UPs feature the advanced circuitry for which RDL products are known, combined with accessible user-friendly controls and displays. The ultra compact design permits high-density installations, with *three* products mounted in a single rack unit! Optional brackets permit mounting a RACK-UP module above, below, or in front of any flat surface!

APPLICATION: The RU-ASX4D is a four channel stereo audio selector with input gain adjustments and output level metering. The inputs and outputs are connected on rear-panel detachable terminal blocks.

Each of the four stereo line level inputs accepts either a balanced or an unbalanced signal. Each input is equipped with a rear panel screwdriver-adjustable input gain trimmer. Input signal levels between -15 dBV and +8 dBu may be set to the proper operating level as indicated by a stereo dual-LED VU meter. This assures ample headroom at all normal operating levels. The module is equipped with two identical sets of stereo dual-led VU meters, one on the front panel, the other on the rear panel. The maximum input level is +25 dBu.

The RU-ASX4D was designed for absolute silent switching of audio signals using only solid-state switching circuitry.

The output is stereo line level. Each output channel may be connected balanced or unbalanced. Each of the VU-meters, left and right, is calibrated to read +4 dBu for the corresponding balanced output.

A front-panel LOCAL/REMOTE switch enables either the front-panel buttons or the rear-panel remote control terminals provided on detachable terminal blocks. In the LOCAL mode, four keyboard style long-life pushbuttons on the front panel are used to select one input. When a button is pushed, the corresponding audio input is fed to the output and any previously selected source is shut off. Only one source may be selected at a time. If the button for a selected source is pushed again, all inputs are turned off. An LED above each pushbutton indicates the selected source. In the REMOTE mode, inputs are selected by a sequential remote control such as an RDL D-RCS4, by a momentary remote control such as an RDL D-RC4M or by an external open-collector momentary closure to ground. The RU-ASX4D may be remote controlled from a single or from multiple locations. When a source is selected, the RU-ASX4D provides a 25 mA open-collector output to control other equipment or modules.

Rear-panel DIP switches are provided to concurrently activate local and remote control, to select the remote control mode (sequential or individual source selection), and upon power-up a return to either a pre-programmed source or to the last source used. The pre-programmed source is stored when the module is installed and can be re-programmed at any time.

The RU-ASX4D offers exceptional headroom, very low distortion, excellent crosstalk isolation, wide flat frequency response and extremely low noise with very high common-mode signal rejection. It provides exceptional audio performance for the most critical applications in a professional audio environment.

The RU-ASX4D operates from 24 Vdc connected through a rear-panel detachable terminal block.



RDL[®]
Radio Design Labs

SPECIALISTS IN PRACTICAL PRECISION ENGINEERING[™]



RACK-UP[®] SERIES

Model RU-ASX4D

Stereo Audio Selector 4x1

Installation/Operation

CE Declaration of Conformity available from rdlnet.com.
Sole EMC specifications provided on product package.
Specifications are subject to change without notice.

- STEP 1: Determine the type of remote control to be used for source selection. Momentary controls use four open-collector transistors or switches (these may be relay contacts, pushbuttons or RDL remote controls) to momentarily connect one input control terminal to ground; one input terminal corresponds to each of the four audio inputs. Sequencing controls use a single input terminal (SEL terminal); a momentary HI (+15 to +24 Vdc) pulse applied to this terminal advances the module to the next audio source; an RDL D Series-RCS4 is typically used. Set the MODE 1 switch to the appropriate remote control type.
- STEP 2: Determine if the module should power up to the "last source used" (before power to the unit was turned off), or if the module should always power up to a pre-defined source. Set the MODE 2 switch to the desired power-up source operation.
- STEP 3: Determine if the VCA activity display should continuously display the last direction change, or if it should only display activity during adjustment. Set the MODE 3 switch for the desired display.
- STEP 4: Determine if any remote devices are to be switched by the module when a source is selected. Connect the remote devices to the SLAVE (open-collector) output terminals on the module. The RU-ASX4DR and the remote devices must share a common ground connection.
- STEP 5: Connect the remote controls to the appropriate control terminals.
- STEP 6: Connect audio to each input that is to be used. With the audio sources active, select each source and adjust the audio level on the rear-panel trimmer, as indicated on the dual-LED VU meters on the rear of the unit.

SETTINGS AND AUDIO WIRING

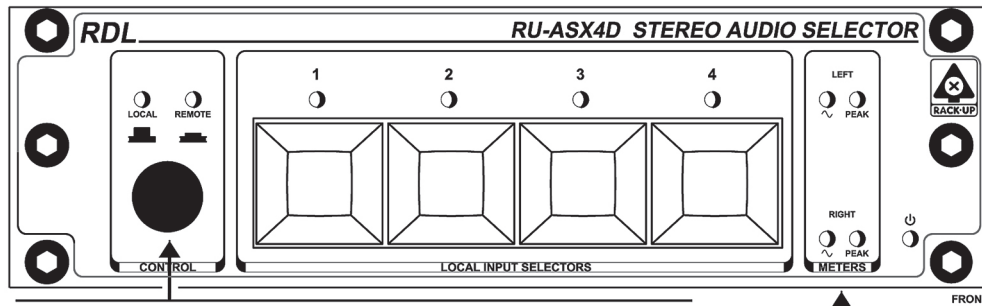

The front-panel selection pushbuttons are only active if the front-panel LOCAL/REMOTE switch is locked in the LOCAL position. In this mode, the front-panel LOCAL LED will be illuminated. In LOCAL mode the remote control inputs may be active or not as set by MODE switch 3. When the LOCAL/REMOTE pushbutton is set to REMOTE the local buttons are always locked out. In this mode the REMOTE LED will be illuminated.

Front Stereo Dual-LED VU meters

Set MODE switch for desired operation. The MODE Switches are Read During Power Up.
MODE Switch 1 RMT CTRL: ON=Read Stepped Remote Control (SEL) Input During Operation
MODE Switch 1 RMT CTRL: OFF=Read Momentary Remote Control Inputs (1 thru 4) During Operation
MODE Switch 2 SOURCE: ON=Initialize Source Selection to the Last Source Used
MODE Switch 2 SOURCE: OFF=Initialize Source Selection to a Stored Default (set by PGM button)
MODE Switch 3 LOCKOUT: ON=Lockout Remote Inputs When Front-Panel Switch is in Local Mode
MODE Switch 3 LOCKOUT: OFF=Enable Remote Inputs When Front-Panel Switch is in Local Mode

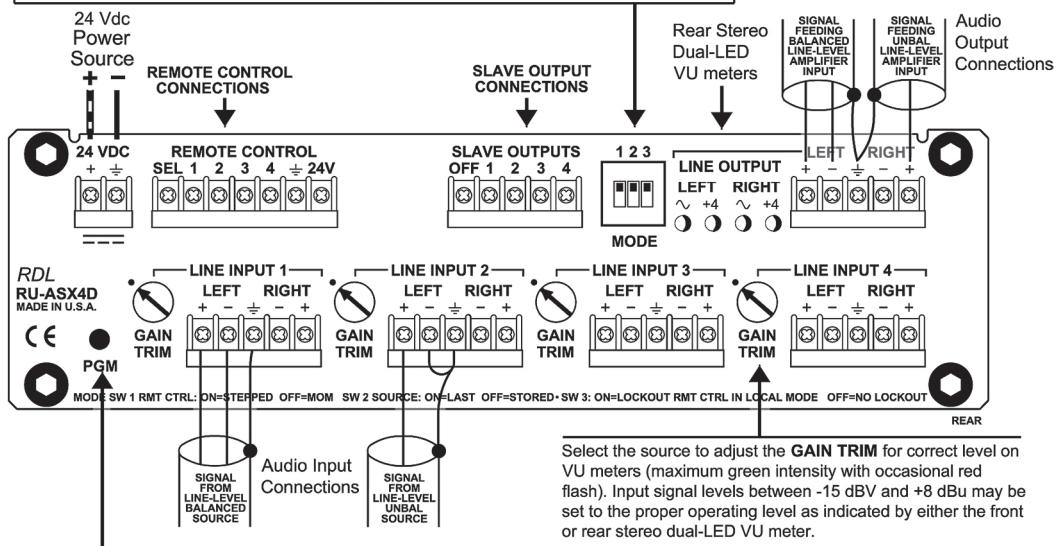

Select the source to adjust the GAIN TRIM for correct level on VU meters (maximum green intensity with occasional red flash). Input signal levels between -15 dBV and +8 dBu may be set to the proper operating level as indicated by either the front or rear stereo dual-LED VU meter.

The PGM pushbutton is used to store which input will be active on power-up if MODE switch 2 is set to the OFF position. Press and hold the PGM button during power up to enter the programming mode. Release the PGM button when the front-panel input select LEDs flash twice (to indicate that the unit is in programming mode). The LEDs will display the stored input source. NOTE: If all four LEDs are off, then no source is selected (unit powers-up with all sources off). Press the PGM button to advance to the next source as indicated by the front panel LEDs. When the desired input is selected no further action is required. After three seconds the unit stores the indicated source and flashes all four source selection LEDs twice to indicate programming is complete.

RU-ASX4D

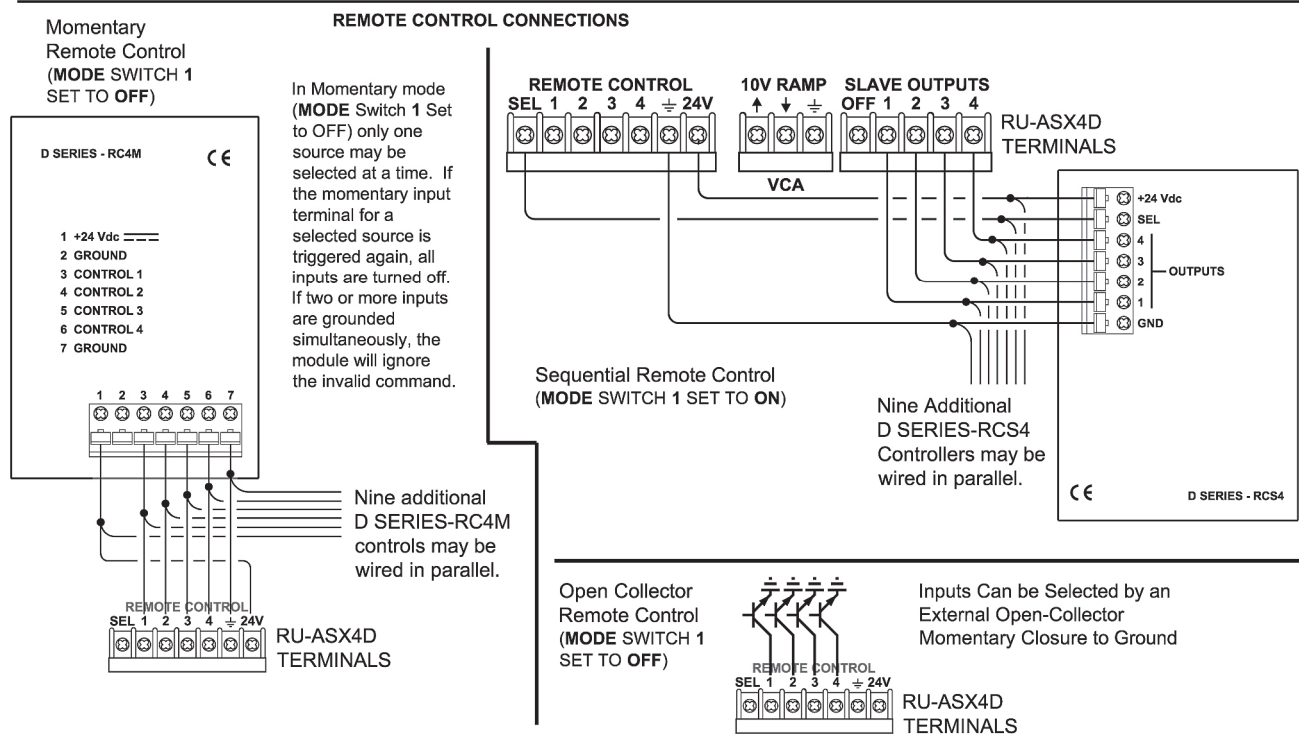

SLAVE OUTPUT CONNECTIONS

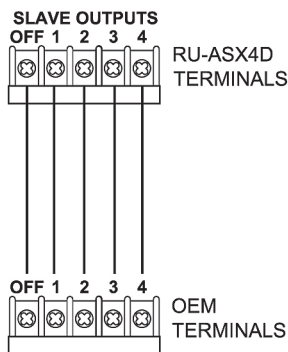

Slave connection 25 mA open-collector output to control OEM equipment or other RDL modules.

The four slave terminals correspond to the selected input. When an input is selected, the corresponding slave output is pulled to ground; all other slave outputs are inactive. (RU-ASX4D and OEM equipment must share a common ground.)

TYPICAL PERFORMANCE

Audio Inputs (4):	Stereo, Line level on Detachable Terminal Block
Input Impedance:	> 20 kΩ balanced, > 10 kΩ unbalanced
Input Level (for +4 dBu output):	-15 dBV to +8 dBu, adjustable on rear-panel trimmers
Maximum Input Level:	+25 dBu
Common Mode Rejection:	> 60 dB (50 Hz to 120 Hz)
Headroom (above +4 dBu):	> 20 dB (unity gain)
Frequency Response:	10 Hz to 20 kHz (±0.2 dB)
Distortion (THD + N):	< 0.01% (20 Hz to 20 kHz)
Noise (below +4 dBu):	< -85 dB (with any input selected); < -95 dB (with no input selected)
Off Attenuation:	> 85 dB (1 kHz), > 70 dB (20 kHz)
Crosstalk:	< -85 dB (1 kHz); < -65 dB (20 kHz)
Front-Panel Switches:	Momentary pushbuttons (4, 1 per input), LOCAL/REMOTE latching pushbutton
Front-Panel Indicators (11):	Power, Selected channel (4), LOCAL/REMOTE selector (2), L and R Dual-LED VU meters (4)
Audio Output:	Stereo, Line level on Detachable Terminal Block
Output Impedance:	150 Ω balanced, 75 Ω unbalanced
Output Level:	+4 dBu balanced, unbalanced output 6 dB below balanced output level
Control inputs (5):	1 mA, pulled to ground (4, source selection); 1 mA, pulled to +15 Vdc (SEL)
Control outputs (5):	25 mA, open-collector to source
Rear-Panel Indicators (4):	L and R Dual-LED VU meters
RDL Remote Control Compatibility:	D-RC4M, D-RCS4
Power Connection:	Detachable Terminal Block
Power Requirement:	24 Vdc @ 150 mA, Ground-referenced
Ambient Operating Environment:	0° C to 55° C

