

AV25-2 User Manual



1 Important safety instructions

1. Please read carefully prior to product installation or operation.
2. Read these instructions.
3. Keep these instructions.
4. Heed all warnings.
5. Follow all instructions.
6. Do not use this apparatus near water.
7. Clean only with dry cloth.
8. Do not block any ventilation openings. Install in accordance with manufacturer's instructions.
9. Do not install near any heat sources such as radiators, heat registers, stoves, or other apparatus (including amplifiers) that produce heat.
10. Do not defeat the safety purpose of the polarized or grounding-type plug. A polarized plug has two blades with one wider than the other. A grounding type plug has two blades and a third grounding prong. The wide blade and/or the third prong are provided for your safety. If the provided plug does not fit into your outlet, consult an electrician for replacement of the obsolete outlet.
11. Protect the power cord from being walked on or pinched particularly at plugs, convenience receptacles, and the point they exit from the apparatus.
12. Only use attachments/accessories specified by the manufacturer.
13. Unplug this apparatus during lightning storms or when unused for long periods of time.
14. Refer all servicing to qualified service personnel. Servicing is required when the apparatus has been damaged in any way, such as power-supply cord or plug is damaged, liquid has been spilled or objects have fallen into the apparatus, the apparatus has been exposed to rain or moisture, does not operate properly, or has been dropped.

2 Approvals

This equipment has been tested and found to be compliant with the limits for Class A Digital device pursuant to part 15 of the FCC rules.

This equipment has successfully passed UL Standard 2043 - Fire Test for Heat and Visible Smoke Release for Discrete Products Installed in Air-Handling Spaces.

3 Warnings

3.1 Explanation of Warning Symbols

3.1.1 Lightning Bolt



The lightning bolt within arrowhead symbol, within an equilateral triangle, is intended to alert the user to the presence of un-insulated “dangerous voltage” within the product’s enclosure that may be of sufficient magnitude to constitute a risk of electrical shock to person.

3.1.2 Exclamation Point



The exclamation point within an equilateral triangle is intended to alert the user to the presence of important operating and maintenance (servicing) instruction in the literature accompanying the appliance.

3.2 Warnings

WARNING: TO REDUCE THE RISK OF ELECTRICAL SHOCK, DO NOT EXPOSE THIS AMPLIFIER TO RAIN OR MOISTURE. DANGEROUS HIGH VOLTAGES ARE PRESENT INSIDE THE ENCLOSURE. DO NOT OPEN THE CABINET. REFER SERVICING TO QUALIFIED PERSONNEL ONLY.

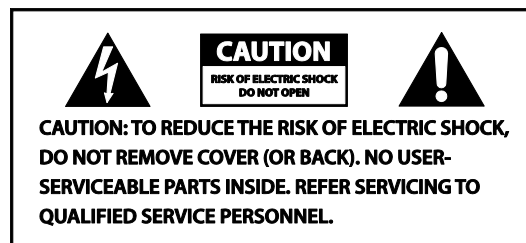

Use only the power supply shipped with the device.

3.3 User Responsibility

3.3.1 Mains Connection Grounding

Your amplifier must be connected to a grounded outlet. Do not defeat the safety purpose of the polarized or grounding-type plug.

3.3.2 Speaker Output Hazard

Power amplifiers are capable of producing hazardous output voltages. To avoid electrical shock, do not touch any exposed speaker wiring while the amplifier is operating. External wiring connected to the speaker terminals shall be installed by a qualified person. Do not connect or disconnect speaker

wires while the mains power is on. Do not connect speaker wires together or to ground as this may result in permanent damage to your amplifier.

3.3.3 Radio Interference

This product has been tested and complies with the EMC directive, and with FCC part 15 Class A. If this product is not used in accordance with these operating instructions, it may cause interference with to other equipment, such as radio and television receivers.

3.3.4 Speaker Damage

Loudspeakers may be damaged or destroyed if overpowered. Always check the loudspeaker's continuous and peak power ratings to prevent such an occurrence. Do not rely solely on the amplifier's volume control to reduce output power to a level safe for the loudspeakers.

3.3.5 Maintenance

Clean regularly with a soft cloth to remove dust and debris. Also check that there is adequate ventilation for convection cooling.

4 Table of Contents

1	Important safety instructions	1
2	Approvals	2
3	Warnings	2
3.1	Explanation of Warning Symbols	2
3.1.1	Lightning Bolt	2
3.1.2	Exclamation Point.....	2
3.2	Warnings	2
3.3	User Responsibility.....	2
3.3.1	Mains Connection Grounding	2
3.3.2	Speaker Output Hazard.....	2
3.3.3	Radio Interference.....	3
3.3.4	Speaker Damage.....	3
3.3.5	Maintenance	3
4	Table of Contents.....	4
5	Welcome	5
5.1	Features.....	5
5.2	Unpacking and Visual Inspection	5
5.3	Installation and Setup	5
5.3.1	Pole Mounting.....	5
5.3.2	Universal Mount Installation.....	6
5.3.3	Cooling and Ventilation.....	6
5.3.4	Operating Voltage	6
6	Rear Panel	7
6.1	Operation	7
6.1.1	Input Connections	7
6.1.2	Speaker Connections.....	8
7	Specifications	10
8	Troubleshooting.....	10
9	Warranty Information	11
9.1	Warranty Summary	11
9.2	Eligibility Requirements	11
9.3	Non-warranty Repairs	11
10	Return Procedure.....	12
10.1	Shipment Instructions	12
10.2	Packaging Instructions	12

5 Welcome

Congratulations on the purchase of your new Stewart Audio AV25-2 audio amplifier. This amplifier has been designed and built to provide you with years of high-quality audio performance and trouble-free operation. If after reading this operation manual you have questions concerning amplifier installation and operation, please contact your Authorized Stewart dealer, or you may contact us directly using the contact information provided on the back of this guide.

5.1 Features

The AV25-2 audio amplifier offers 2 channels of clean, full-range, dynamic audio with 25W output power per channel in a sub-compact ¼ rack enclosure. It has been optimized for 4Ω and 8Ω loudspeakers. The Signal Detect circuitry automatically places the amplifier in sleep mode and wakens it when a signal is present. The contact-closure terminals mute the audio output for fire alarm applications. **(Amplifiers shipped before 10/23/2018 have a serial number beginning with SA. On these models a voltage of +5VDC to +10VDC (between the mute and ground pins) is required to mute the amplifier.)** There are multiple mounting options to fit a variety of applications. The external in-line power supply provides plenty of power to achieve full, rated audio output power.

This product is proudly manufactured in the USA.

5.2 Unpacking and Visual Inspection

Every Stewart Audio product is carefully tested and inspected before leaving the factory and should arrive in perfect condition. If any damage is discovered, please notify the shipping carrier immediately. Save the packing materials for the carrier's inspection and for any future shipping.

5.3 Installation and Setup

5.3.1 Pole Mounting

The AV25-2 amplifier is Stewart Audio's first line of pole-mountable amplifiers. The AV25-2 has mounting holes on both the top as well as the side of the unit, which can be used with the AV-Pole bracket available from Stewart Audio.

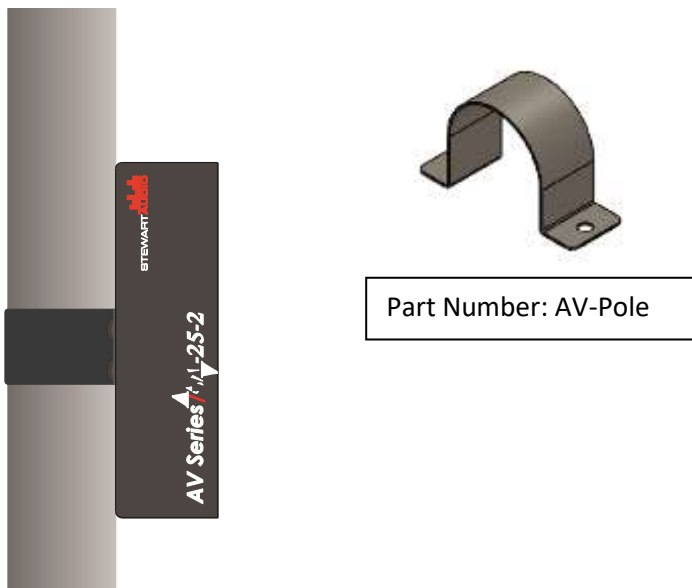

5.3.2 Universal Mount Installation

The AV25-2 also has a universal mount bracket available which allows the unit to be mounted against a wall or under a table. Two screws are included in the kit, which will affix the bracket to the top or side of the unit. Two holes in the bracket are available for mounting the unit where desired.

5.3.3 Cooling and Ventilation

The AV25-2 is a convection-cooled amplifier. Ensure that there is sufficient open space around the amplifier to allow for free air flow. Do not stack amplifiers on top of each other or mount amplifier in a way that air flow around the unit will be impaired. Inadequate airflow around the amplifier may cause the amplifier to overheat and potentially become damaged as a result

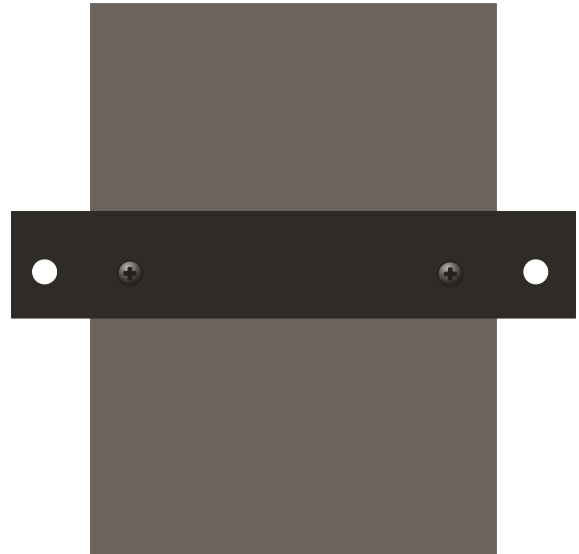

Part Number: AV-Bracket

5.3.4 Operating Voltage

The AV25-2 is shipped with an in-line power supply. This is a universal power supply that operates on AC mains from 100-240V at 50 or 60 Hz. The 48VDC output from this supply is connected to the rear of the amplifier. **Use only the power supply shipped with the amplifier.**

6 Rear Panel

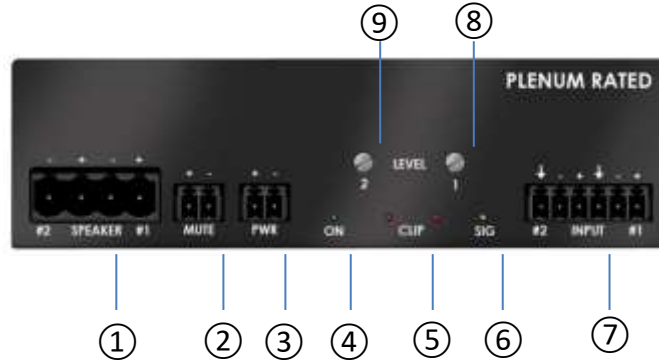

1. **Speaker Output Connectors** – 3.5mm Eurostyle connections to low impedance speakers (4/8Ω).
2. **Contact Closure Mute connectors** – 3.5mm Eurostyle mute connector. Short terminals to mute; open to unmute.
3. **48VDC Power Connector** – Connect 48VDC output from in-line power supply shipped with unit. There is no on/off switch; the amplifier is on whenever the power is applied. **Stewart Audio recommends connecting the power to the amplifier *before* the in-line power supply is plugged into the AC receptacle.**
4. **Power Indicator** – This blue LED illuminates when DC power is applied. Note that this will dim when the amplifier is in sleep mode (approximately 5 minutes with no input signal on either channel).
5. **Clip Indicators** – These red LEDs illuminate when an excessive input signal levels are applied. Reduce signal level to avoid distortion.
6. **Signal Present Indicator** – The green LED illuminates to indicate an input signal is present on either channel.
7. **Input Connectors** – Connect audio sources via these 3.5mm Eurostyle connectors.
8. **Channel 1 Level Control** – Turn fully clockwise for maximum output on output 1. Note that the input sensitivity of the AV25-2 is 0.5V_{rms}. Do not overdrive the amplifier.
9. **Channel 2 Level Control** – Turn fully clockwise for maximum output on output 2.



In normal operation, the DC voltage on the speaker output connectors is approximately 24VDC. Do not connect any speaker output to ground or to the amplifier chassis. Do not connect speakers across speaker outputs. (Bridge mode is not supported.)

6.1 Operation

6.1.1 Input Connections

Your AV25-2 amplifier is provided with a 3-pin Phoenix connector for each input. This connector will accept balanced or unbalanced connections, however some modifications must be made for an unbalanced connection. See the next two sections for instructions on connecting your amplifier to its input source.

6.1.1.1 Balanced Connections

When using a balanced input source and connector, you must ensure that the hot, cold, and ground pins of the connector are matched up to the +, -, and ground pins of the AV25-2's Phoenix connector respectively. Diagrams have been provided for standard XLR and TRS connectors. Please refer to the manual of your input source in case it does not follow the standard pin-out

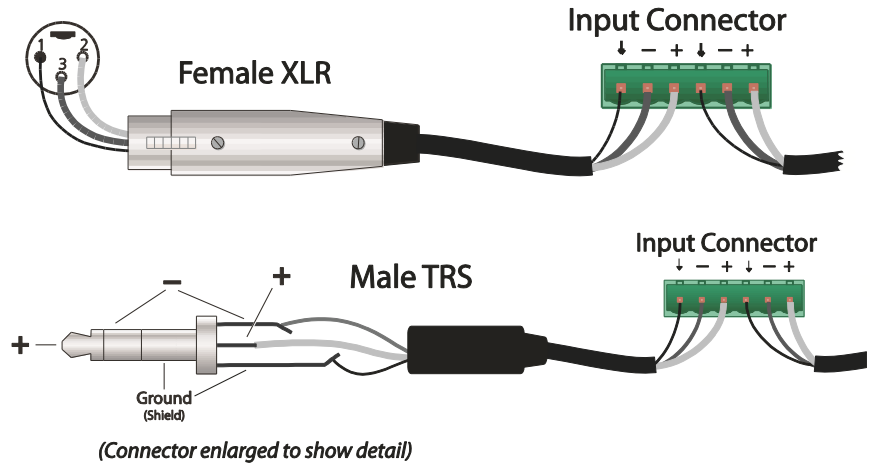

6.1.1.2 Unbalanced Connections

When using an unbalanced input source and connector, a jumper must be added between the negative (-) terminals and the ground terminals. Then the unbalanced source can be connected to the positive (+) and ground terminals. Diagrams have been provided for standard RCA and TS connectors. Please refer to the manual of your input source in case it does not follow the standard pin-out.

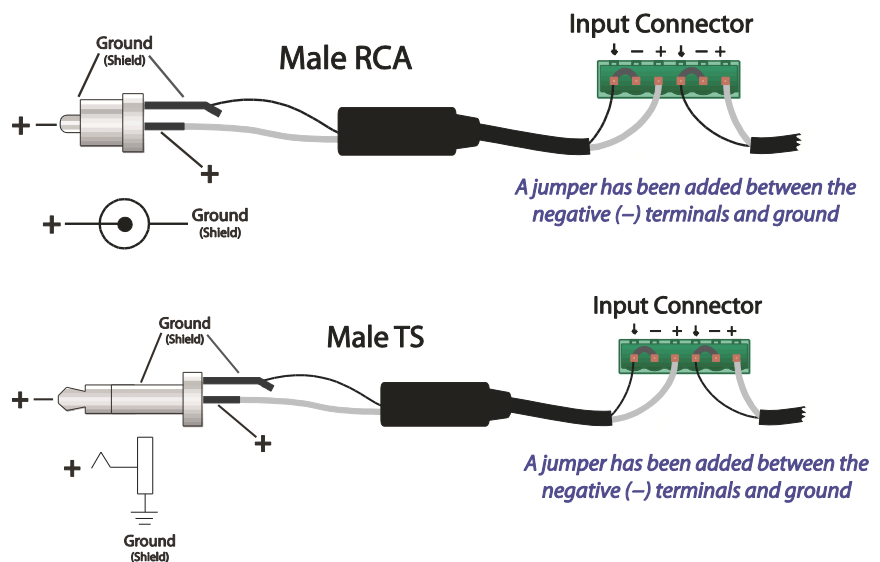

6.1.2 Speaker Connections

Stewart Audio recommends using high-quality, heavy-gauge speaker wire and connectors to send the output signal of your amplifier to the speakers. Use the following table as a guideline when selecting your wire gauge.

Distance	Wire Gauge
Up to 25 ft.	16 AWG
26-40 ft.	14 AWG
41-60 ft.	12 AWG

Speaker leads connect by means of removable terminal block connectors supplied with the unit. Strip speaker leads 1/4" and insert into connector observing proper polarity. With a small, flat-blade

screwdriver, tighten the screw until the leads are held securely in place. Inspect for possible shorts or broken wires.

In normal operation, the DC voltage on the speaker output connectors is approximately 24VDC. Do not connect any speaker output to ground or to the amplifier chassis. Do not connect speakers across speaker outputs. (Bridge mode is not supported.)

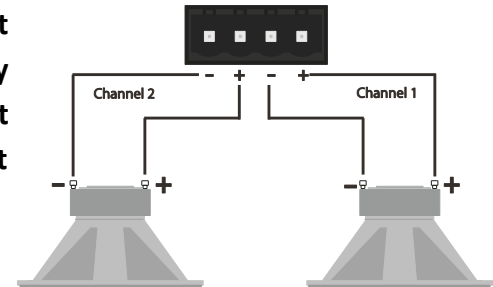

NOTE: Class 2 wiring must be used on the speaker terminals to comply with UL requirements.



CAUTION: Do not connect either speaker terminal to ground. This will cause a short circuit which may damage the amplifier, speaker, or both. Similarly, do not connect any speaker terminal to ground.

7 Specifications

Max. Output Power (all channels driven)	
4 Ω Stereo Power	▪ 35W/channel
8 Ω Stereo Power	▪ 25W/channel
Performance	
Frequency Response (+0, -3dB, 1W)	▪ 30 Hz – 20 kHz
Power Bandwidth	▪ 30 Hz – 30 kHz
Signal to Noise Ratio	▪ >95 dB
THD+Noise	▪ <0.1% @ full power
Signal to Noise Ratio	▪ >100 dB
External Mute	▪ Contact Closure
Slew Rate	▪ 30V/microsecond
Input Sensitivity	▪ 0.5V (-6 dBV)
Standard Voltage Gain	▪ 28X (26.5 dB)
Input Impedance (Balanced/Unbalanced)	▪ 20kΩ/10kΩ
Standby, Idle Current Draw; 1/8 Power Draw	▪ 5mA, 10mA, 7.2W
Characteristics	
Amplifier Class	▪ D
Input Connectors	▪ 3.5mm Euroblock
Output Connectors	▪ 3.5mm Euroblock
Power Supply	▪ External in-line 48VDC (included)
Cooling -----	▪ Convection (no fan)
Controls	▪ Level, Mute
LED Indicators	▪ Power, Signal Present, Clip (2)
Construction	▪ Aluminum Enclosure
Dimensions (Length, Width, Height) -----	▪ 3.2" X 4.35" X 1.25" (81mm X 110mm X 32mm)
Weight-----	▪ < 0.37 lbs. (0.16kg)
Warranty-----	▪ 3 years
Plenum Rating	▪ UL2043 Compliant

8 Troubleshooting

Power indicator (LED) is not illuminated.

- Check that the amplifier is plugged into a live outlet. Apply an input audio signal to one or both inputs to wake the amplifier from sleep mode. After you have ensured that it is not a power issue and that the amplifier is not in sleep mode, disconnect any speakers. If the amplifier turns on after a few seconds delay, then the problem is in the output connection. Check wiring and speakers for short circuits. Make certain that the speaker leads are not grounded.

No output on one or both channels; Power indicator is lit.

- Check that level controls are not turned down. Check that input and output connections are secure. Ensure signal present LED is illuminated to denote a signal. If there is no signal detected check signal source and that level controls are set high enough.

Amplifier overheats and/or shuts off.

- Review [section 5.3.3](#) on proper cooling procedures. Check the signal lights on the rear of the amplifier to see if the signal is overdriving (the clip light flashes red frequently). Overdriving the amplifier for extended periods of time can result in a thermal shutdown.

Output sound is distorted or cracking.

- Check all cables for damage or loose connections and reduce the gain on the input signal at the mixer or preamp level. Replace the cables and loudspeakers temporarily to see if this resolves the problem. If problem still exists, contact your Authorized Dealer for service.

9 Warranty Information

9.1 Warranty Summary

All Stewart Audio amplifiers and accessories, unless excluded in this summary, are covered by a 3-year limited warranty on parts and labor from the date of purchase. In order to be eligible for warranty repairs, the amplifiers and accessories must have been purchased through an authorized Stewart Audio dealer and submitted by the original purchaser. This warranty is only valid in the country in which the amplifier was purchased.

9.2 Eligibility Requirements

Stewart Audio warrants against all malfunctions which come as a result of component or manufacturer defect. The amplifier is also covered from all failures which arise during the warranty period (3 years from date of purchase) that are not a result of misuse. The following actions will void your warranty:

- The power cord or AC plug has been damaged through misuse.
- The amplifier has been exposed to moisture or extreme temperatures.
- The amplifier has been dropped, items have been dropped on the amplifier, or the enclosure has been damaged.
- The amplifier has been opened by the operator.
- The amplifier was improperly packaged when sending to the factory for repair, resulting in damage.
- Any of the precautions or instructions found in this manual were not followed.

Damages resulting to the amplifier which are not covered under this warranty can be factory-repaired at cost to the customer. Use the contact information below to initiate the repair process.

9.3 Non-warranty Repairs

An estimate for all non-warranty repairs will be provided to the customer once the unit has been

shipped to the factory. The customer is responsible to approve this estimate within 7 days. If the repairs are not approved within 14 days, Stewart Audio reserves the right to consider the unit scrap and may discard it. Payment for non-warranty repairs must be submitted to Stewart Audio before the product will be returned to the customer.

10 Return Procedure

All returns to the factory for service must be accompanied by a Return Authorization (RA) number. One can be obtained by contacting Stewart Audio at (209) 588-8111 or via e-mail at support@stewartaudio.com.

NOTE: Any defective products received without an RA number will be returned to sender at their expense.

If Stewart Audio is unable to contact the sender in 14 days, the merchandise will be considered scrap and may be disposed of.

10.1 Shipment Instructions

- If Stewart Audio requests that you ship the defective product back to their service center, please refer to the guide below. To ensure prompt warranty service, be sure to follow all instructions.
- Return Authorization (RA) is required for product being sent to the factory for service.
- See packing instructions in [Section 10.2](#).
- Ship the defective product using a method which provides for order tracking or order confirmation. The service center is located at the following address:

Stewart Audio
14335 Cuesta Court Suite C
Sonora, CA 95370

- Use a bold black marker and write the RA number on three sides of the box.

Record the RMA number for future reference. The RA number can be used to check the repair status.

10.2 Packaging Instructions

Should Stewart Audio request that you ship your product to their service center, these instructions must be followed in order to ensure safe delivery. If they are not followed, Stewart Audio assumes no responsibility for damaged goods and/or accessories that are sent with your unit.

1. Please write the RA number on three sides of the box. Include the Stewart Audio RA number inside the box and a brief description of the problem.
2. You will be advised during the RA process what accessories should be included with the amplifier (power supplies, connectors, cords, etc.). This is dependent on the failure

assessment.

3. When shipping your amplifier, it is important that it has adequate protection. We recommend you use the original packing material when returning the product for repair. If you do not have the original box, see number 4.
4. If you provide your own shipping pack, use materials adequate to prevent damage during transit. Make certain that the amplifier is NOT free to move within the package, as this is the most common cause of damage.
5. Securely seal the package with an adequate carton sealing tape.
6. Do not use light boxes or “peanuts”.

NOTE: Damage caused by poor packaging will not be covered under warranty.