

# 110 & 66 Punch Down Tool

## Package Includes:

- A. Punch Down Tool, 1 PC
- B. 110 Blade, 1 PC
- C. 66 Blade, 1PC
- D. Blade Cap, 1 PC
- E. Instruction Sheet

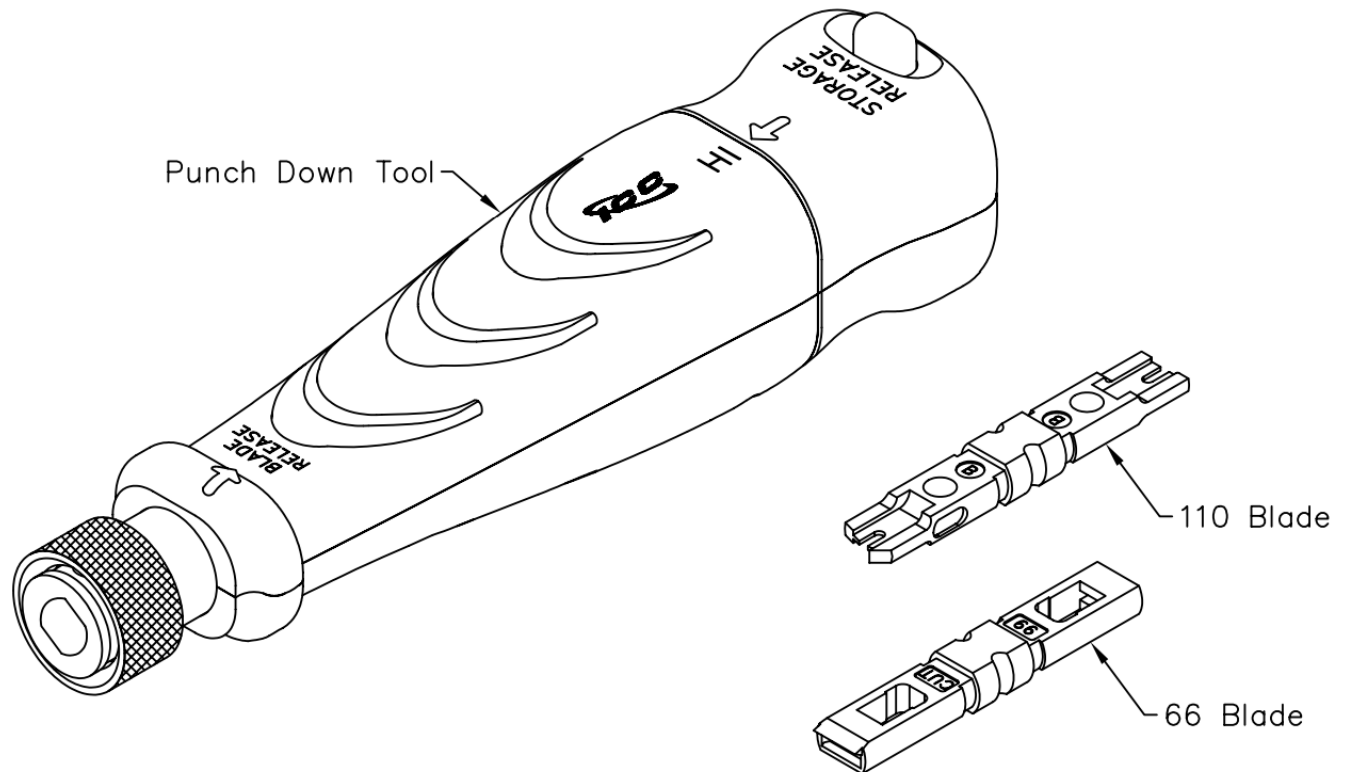

## Features and Benefits

- Designed for both 110 and 66 single-wire termination with both blades included
- Ergonomic design for fast, comfortable, and reliable termination
- High and low impact settings allowing more flexibility during punch down operations
- Low impact setting allows punching down wiring blocks and 110 patch plugs, modules, faceplates, and patch panels with IDC termination, and high impact setting is used when seating 110 connecting blocks into 110 wiring blocks
- Instructions included
- Country Of Origin: Taiwan
- TAA Compliant

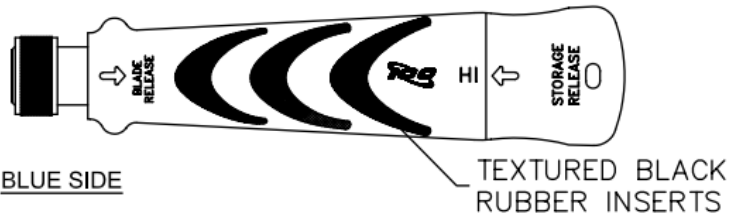

BLUE SIDE

BLUE PUSH BUTTON FOR RELEASE OF BLADE FROM STORAGE

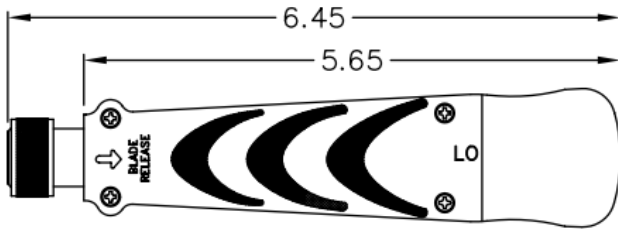
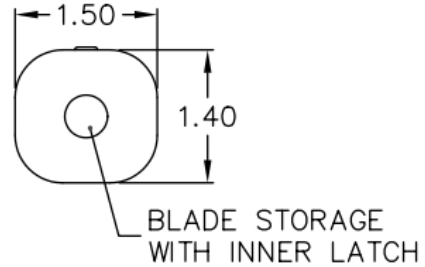
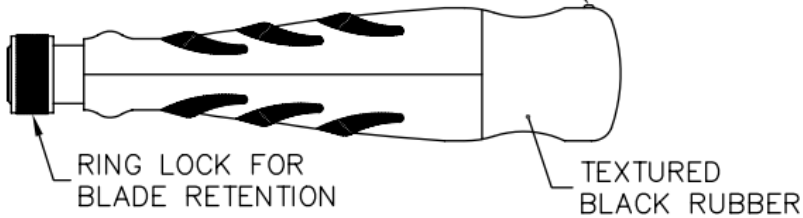

YELLOW SIDE

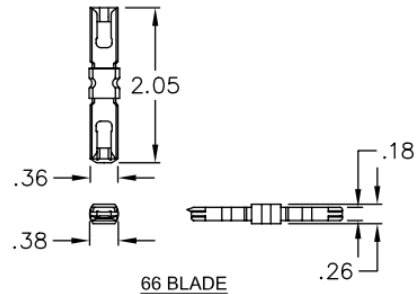
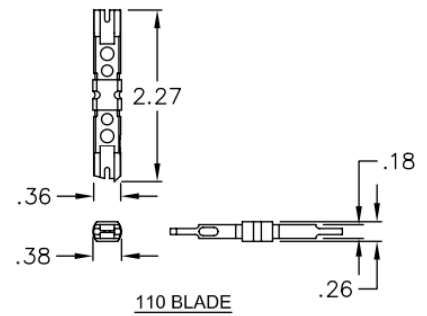

**NOTE: UNLESS OTHERWISE SPECIFIED**

1. MATERIAL:
  - A. BODY: ABS, FIBER, AND THERMOS PLASTIC RUBBER
  - B. NECK: CRS
  - C. BLADE: AISI 4140
2. COLOR:
  - A. BODY: BLUE AND YELLOW
  - B. RUBBER INSERTS: BLACK
  - C. NECK: PLATED BLACK
3. FINISH;
  - A. BODY: MATTED TEXTURE
4. HARDNESS:
  - A. BLADE: HRC 40-52°
5. MECHANICAL:
  - A. LOW IMPACT: 11 KGS (FOR 24 & 26 AWG WIRES)
  - B. HIGH IMPACT: 15 KGS (FOR 22 AWG WIRES)



**Rhox Áudio e Vídeo Profissional** - SIBS Quadra  
 2 conjunto C Lote 12 Brasília - DF - 71736.203 -  
 Tel (61) 3051-5800  
<https://loja.rhox.com.br>



Part No: ICACSPDT00

Rev: A

Page 2 of 2

| 888-ASK-4ICC | [icc.com](http://icc.com) | [csr@icc.com](mailto:csr@icc.com) |