

Description

Using one shielded category cable drop, the RAD26 provides any room with a dual 4-watt amp, end user control via a color custom LCD display & encoders, a dual universal audio I/O interface, plus headphone output and line-level input jacks for local needs. Three logic closure inputs and three active-low outputs add to the control capabilities. The amplifier permits a single channel option at 8 watts into 8Ω. Applications include:

- Presentation source and volume, projector and screen control.
- Meeting room with A/V teleconferencing and speakers.
- Spa with BGM, local music input and stereo ceiling speakers.
- Hotel or cruise ship room TV and local input sound system.

A RAD26 provides enough I/O and control to support one room in a HAL audio system which may require these features:

- Local audio line input (smartphone, laptop, MP3, DVD)
- One or two microphone or line-level inputs
- Amplifier outputs for ceiling speakers
- Level control
- Source selection.

Each RAD26 may be installed onto a standard US 2-gang electrical box, 1-gang electrical box, or flush-mounted to a wall surface. The exterior finish is matte white.

Source and level behave like a DR3 remote, but with any combination of Levels, Toggles, Selections or Commands.

On the back there are 2 balanced Euroblock Mic / Line / Line-Plus audio inputs with the mode set in Halogen software. The Line-Plus inputs accept unbalanced left and right signals and sums them to mono. 24V phantom power is available for condenser mics. For end users, there is a 3.5 mm Aux input on the underside of the front, accepting the output of a smartphone, laptop or other consumer device.

A built-in 4-watt stereo amplifier powers a small stereo pair of room speakers, or this amp can be switched in software to power a single 8-watt speaker. Balanced line outputs can drive an external amplifier or powered subwoofer for more output.

Software logic senses an inserted connector at the Aux In or Headphone jacks to optionally override the rear connections.

RAD26 TOP VIEW

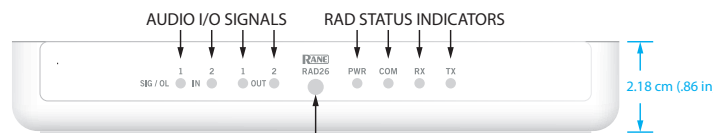

The Ambient Light Sensor dims the display and LEDs in darkened rooms.

REAR PANEL INPUTS

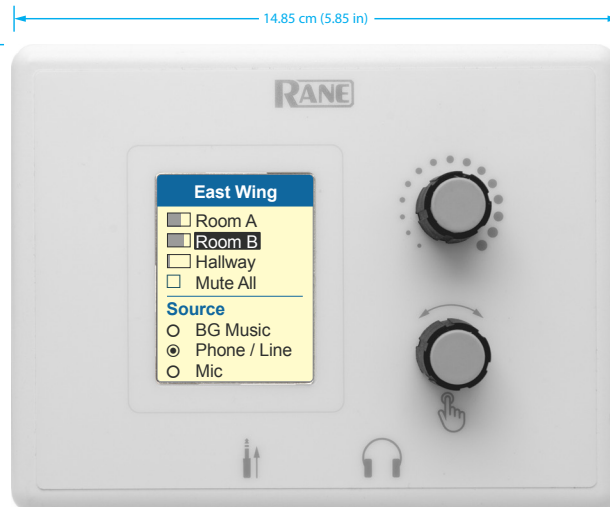
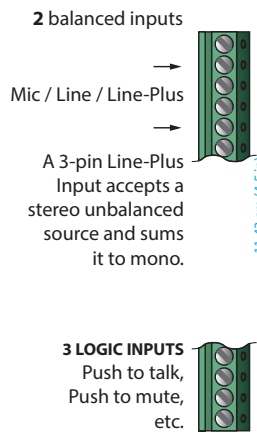

REAR PANEL OUTPUTS

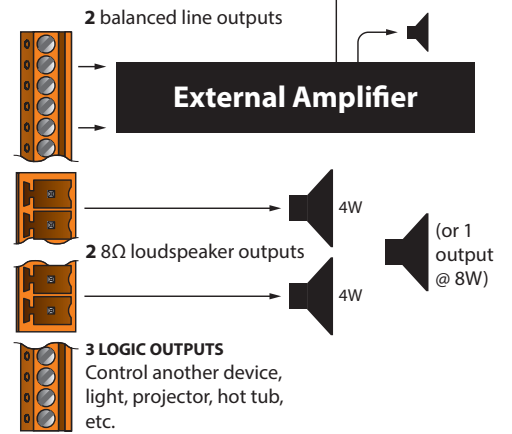

RAD26 BOTTOM VIEW

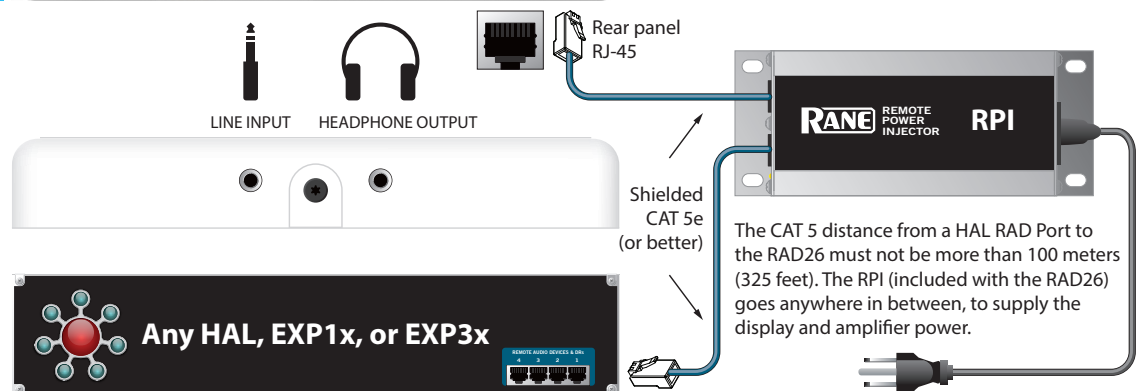

Specifications

Parameter	Specification	Limit	Units	Conditions/Comments
Signal Indicators	-50	typ.	dBFS	Unbalanced / balanced output, green LED, peak-reading
Overload Indicators	-0.5	typ.	dBFS	Unbalanced / balanced output, red LED, peak-reading
Microphone Input Specs (level set in software) (2.54mm Euroblock Terminal)				
Input Impedance	2.16 k	typ.	Ω	Balanced, 1.08 k + 1.08 k
Gain Range (dynamic mic mode)	30 to 50	typ.	dB	In 1 dB Steps
Gain Range (condenser mic mode)	18 to 38	typ.	dB	In 1 dB Steps
Max. Input (dynamic mic mode)	-16	typ.	dBu	-18 dBV, Balanced, Gain = 30 dB
Max. Input (condenser mic mode)	-4	typ.	dBu	-6 dBV, Balanced, Gain = 18 dB
Equivalent Input Noise	-126	typ.	dBu	20 kHz BW, $R_s = 150 \Omega$, Gain = 30 dB
CMRR	-70	max.	dB	$R_s = 150 \Omega$, 1 kHz, Gain = 30 dB
Frequency Response	20 to 20 k	typ.	Hz	+0, -0.5 dB, at all Gain settings
THD + Noise	0.008% typ.	@ 1 kHz, 20 kHz BW, $R_s = 150 \Omega$, Output = -6 dBFS, Gain = 30 dB		
Phantom Power	24	2%	V	10 mA Max, always on in Condenser Mic Mode
Balanced Line-Level Input Specs (2.54mm Euroblock Terminal)				
Input Impedance	10 k	1%	Ω	Balanced
Gain Range	0 to 20	typ.	dB	In 1 dB Steps
Max. Input Level	14	max.	dBu	12 dBV
Frequency Response	20 to 20 k	typ.	dB	+0, -0.5 dB
Dynamic Range (input)	103	typ.	dB	re: 0 dBFS, 20 kHz BW, A-weighted
THD + Noise	0.008% typ.	@ 1 kHz, 20 kHz BW, $R_s = 150 \Omega$, Output = -6 dBFS, Gain = 0 dB		
Line+ Mode	Active Summer			Left ("+") and Right ("-") signals summed to mono
Max. Input Level L+R	14	max	dBu	12 dBV
Auxiliary Input (3.5 mm Stereo TRS Switching Connector)				
Gain	0 to 20	typ.	dB	In 1 dB Steps
Max. Input Level	12	max.	dBu	10 dBV
Dynamic Range (input)	101	typ.	dB	re: 0 dBFS, 20 kHz BW, A-weighted
Frequency Response	20 to 20 k	typ.	dB	+0, -0.5 dB, at all Gain settings
THD + Noise	0.008% typ.	@ 1 kHz, 20 kHz BW, $R_s = 150 \Omega$, Output = -6 dBFS, Gain = 0 dB		
Balanced Line-Level Output Specs (Active Balanced) (2.54mm Euroblock Terminal)				
Output Impedance	200	1%	Ω	Each Leg
Max. Output Level	14	min.	dBu	< 1% THD, Load = 10 k Ω
Dynamic Range	104	typ.	dB	re: 0 dBFS, 20 kHz BW, A-weighted
Frequency Response	20 to 20 k	typ.	Hz	+0, -0.5 dB, at all Gain settings
THD+Noise	0.01% typ. @ 1 kHz, 20 kHz BW, $R_s = 150 \Omega$, Output = +4 dBu, RAD26 Input to Output			
Headphone Output (3.5 mm Stereo TRS Switching Connector)				
Maximum Output	130	typ.	mW	per channel, $R_{load} = 32 \Omega$
Minimum Load	32		Ω	
Amplifier Outputs (Full Bridge Class D Power Amplifier)				
Max. Output Power (Dual Mode)	4	max.	W	8 Ω load, < 0.1% THD, both channels
Max. Output Power (Single Mode)	8	max.	W	8 Ω load, < 0.1% THD, Ch. 1 only, Ch. 2 disabled
Dynamic Range	99	typ.	dB	re: 0 dBFS, 20 kHz BW, A-weighted, Dual 4W Mode
Frequency Response	20 to 20 k	typ.	Hz	+0, -0.5 dB, at all Gain settings
THD + Noise	.02% typ.	@ 1 kHz, 20 kHz BW, $R_{load} = 8 \Omega$, Output = 1 W		

Parameter	Specification	Limit	Units	Conditions/Comments
Logic Specs				
Logic Inputs	3			Contact closure to ground (2.54 mm Euroblock Terminal)
...Internal Pull-up	51.1 k	1%	Ω	5.0 V
...Logic High Input Level	> 2.0	min.	V	Normal State
...Logic Low Input Level	< 0.9	max.	V	External circuit must sink > 80uA to assert
Logic Outputs	2			Relay drive, LED or logic level output (2.54 mm Euroblock Terminal)
...Internal Pull-up	1.0 kΩ	1%	Ω	5.0 V, Protected to 30 V, reverse polarity protected
...Sink Current	200	max.	mA	Output FET on
...LED Drive Current	2		mA	Output FET off, driving an LED with Vf = 2.0 V
...Logic High Input Level	4.7	min.	V	Output FET off, Output Current = 0 mA
...Logic Low Input Level	0.1	max.		Output FET on, Sink Current < 200 mA
Color Display				
Size	49.8 x 37.5 mm			1.96" x 1.48"
Resolution	320 x 240			Pixels
Color Depth	16-bit			131,071 colors
Backlight Brightness	320 cd/m2	typ.		Adjustable in software from maximum to off in 10 steps
Ambient Light Sensitivity	Software configurable to adjust how sensitive the RAD26 screen is to changes in ambient light			
RPI Unit (Remote Power Injector) included with each RAD26				
Data Input Port	To a RAD Port on a HAL			Shielded CAT 5e cable or better, RJ-45 connectors.
Data Output Port	To the RAD26			Shielded CAT 5e cable or better, RJ-45 connectors.
...Power	24 VDC 24 VDC @ 550 mA maximum.			
HAL to RAD26 Distance	100 meters / 325 feet total maximum. RPI can be anywhere in between.			
Power Requirement	100 to 240 VAC			50/60 Hz, 18 W max
Size	4.6 x 17.6 x 7 cm			1.78" x 6.9" x 2.79"
Weight	400 g			14.1 oz
Included Mounting Hardware with each RAD26				
Wall Bracket Size	124 x 76.2 mm			4.875" x 3.875"
Mounting Screw	#6-32x1/4" Torx T10 (qty 1) secures the RAD26 to the wall bracket.			
Box / Wall Screws	#6-20x1-1/4" (qty 4) Drywall / cement anchors are also included.			
RB2 Rack Bracket Accessory (optional)				
Size: 3U, black painted steel	13.2 x 48.3 x 1 cm			5.2"H x 19"W x .4"D
Speaker Mounting Bolt Circle Diameter	120 mm (4.7") ±0.05" in.			EIA 4" loudspeaker "standard"
Mechanically compatible speakers according to their data sheets:				1. Atlas FC-104 (tested and known to fit) 2. Lowell JR410 (untested but holes are properly placed) 3. Electro-Voice 205 (untested but holes are properly placed)
Weight	480 g			1 lb 1 oz
Shipping Weight	850 g			1 lb 14 oz
RAD26 Unit				
Wiring	Class 2			
Conformity	CE, FCC, cULus			
Ambient Room Temperature	40 °C / 104 °F			
Size	149 x 115 x 22.5 mm			5.87 x 4.53 x .87 inches
...Depth Including the Knobs	40 mm			1.58 inches
Weight	617 g			1 lb 6 oz
Shipping (RAD26 with RPI)	tbd			tbd

RAD26

ONE ROOM RAD REMOTE



RAD26 Meeting or Classroom Application

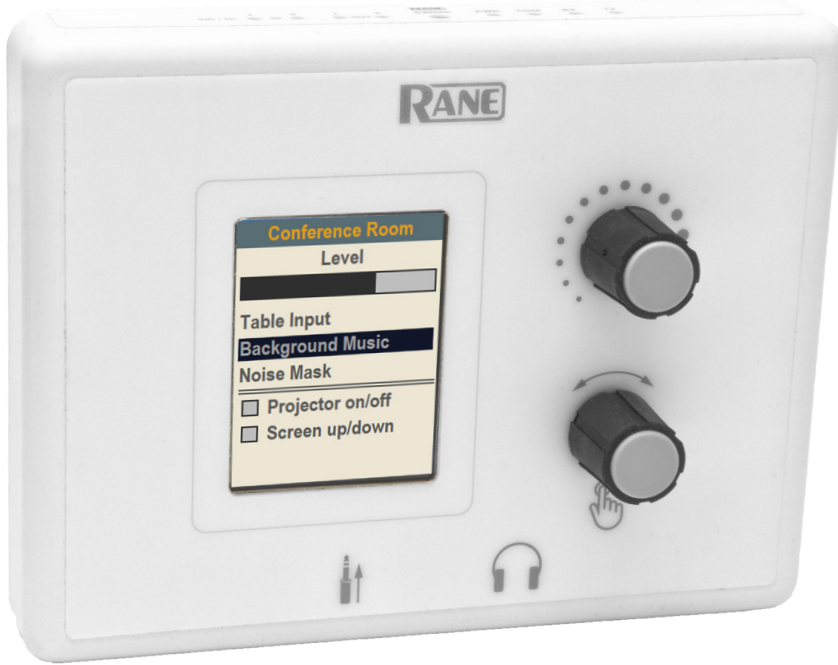

This configuration works for presentations in both boardrooms and classrooms.

The mic connects to the rear of the RAD26. It can be from a ceiling mic, or from a hand-held or lavalier wireless mic, with 24V phantom power available for condenser mics.

A presenter can easily plug a laptop, tablet or smartphone into the sound system. A regular consumer cable with stereo 3.5 mm line plugs will work.

When no plug is present, background music or noise masking is available, sent from a HAL multiprocessor elsewhere in the building. A RAD26 selection decides which source, and how loud.

The amplifier is set to dual 4 watt mode to drive the left and right speakers.

The logic outputs can be configured as toggle controls to move the motorized screen up and down, and turn the projector on and off.

HAL lets you page into this room, ducking the local audio, or overriding it — automatically.

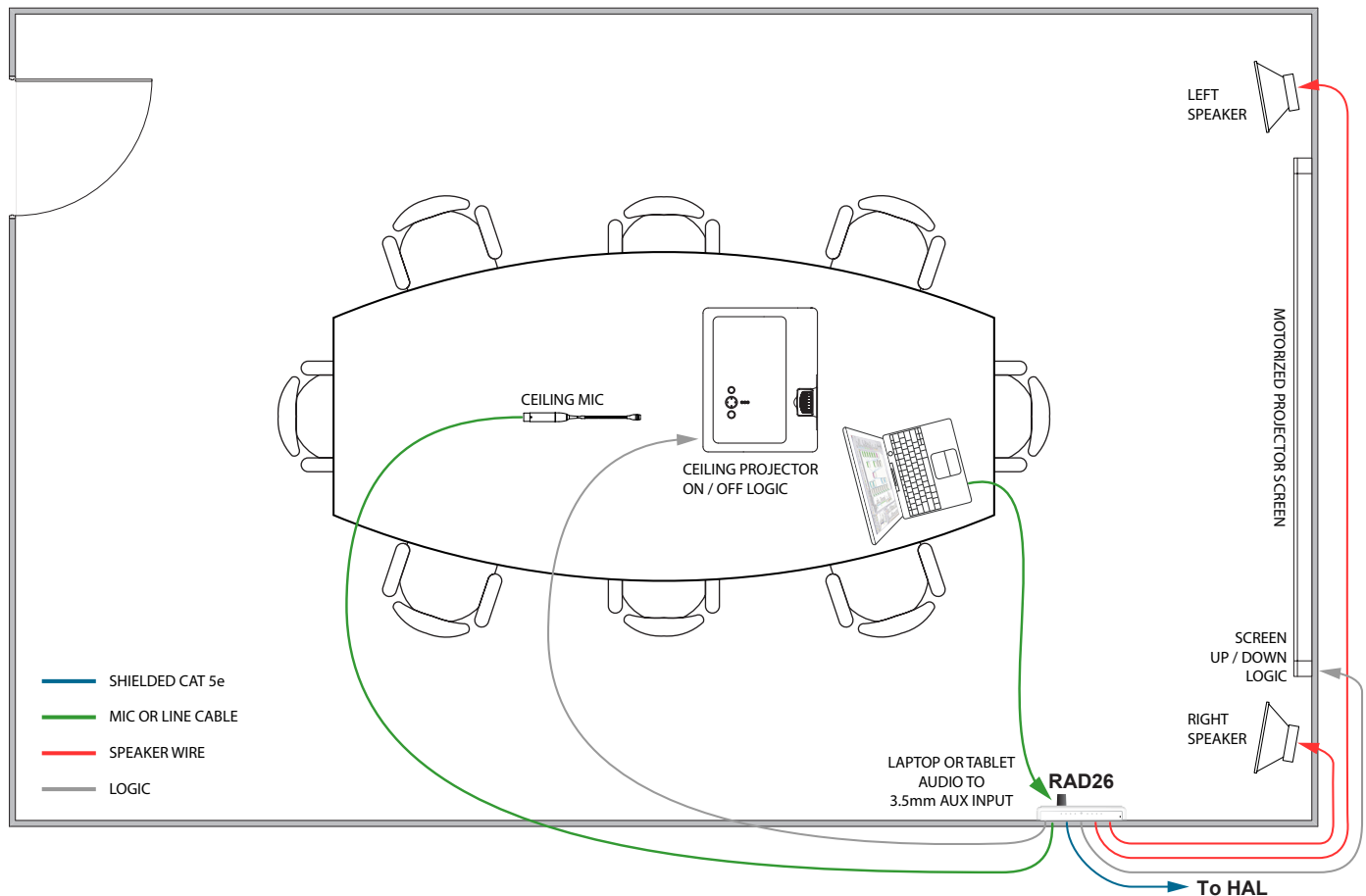

RAD26 Hotel or Cruise Ship Guest Room Application

This configuration works for private guest rooms in hotels, resorts, and cruise ships.

The television line output connects to the rear of the RAD26, delivering better sound than the TV speakers. In-house video can deliver shows to guests, virtually expanding theater capacity to the entire ship or resort.

A guest can easily plug a laptop, tablet or smartphone into the sound system, using a regular consumer stereo 3.5 mm line plug cable.

On cruise ships, important messages from the captain must be heard in the room speakers. The volume control can be set for minimum and maximum levels so that important pages aren't missed, yet the guest is given volume control.

The amp is in dual 4 W mode to drive the two ceiling speakers. Depending on source material and speaker locations, stereo TV audio can wire to the two line inputs, or as Line-Plus left and right sum to mono. If the TV is mono'ed, the other input could be a local talkback mic.

When a guest's headphones are plugged in, the room speaker amplifiers can be optionally muted for the spouse to get some sleep.

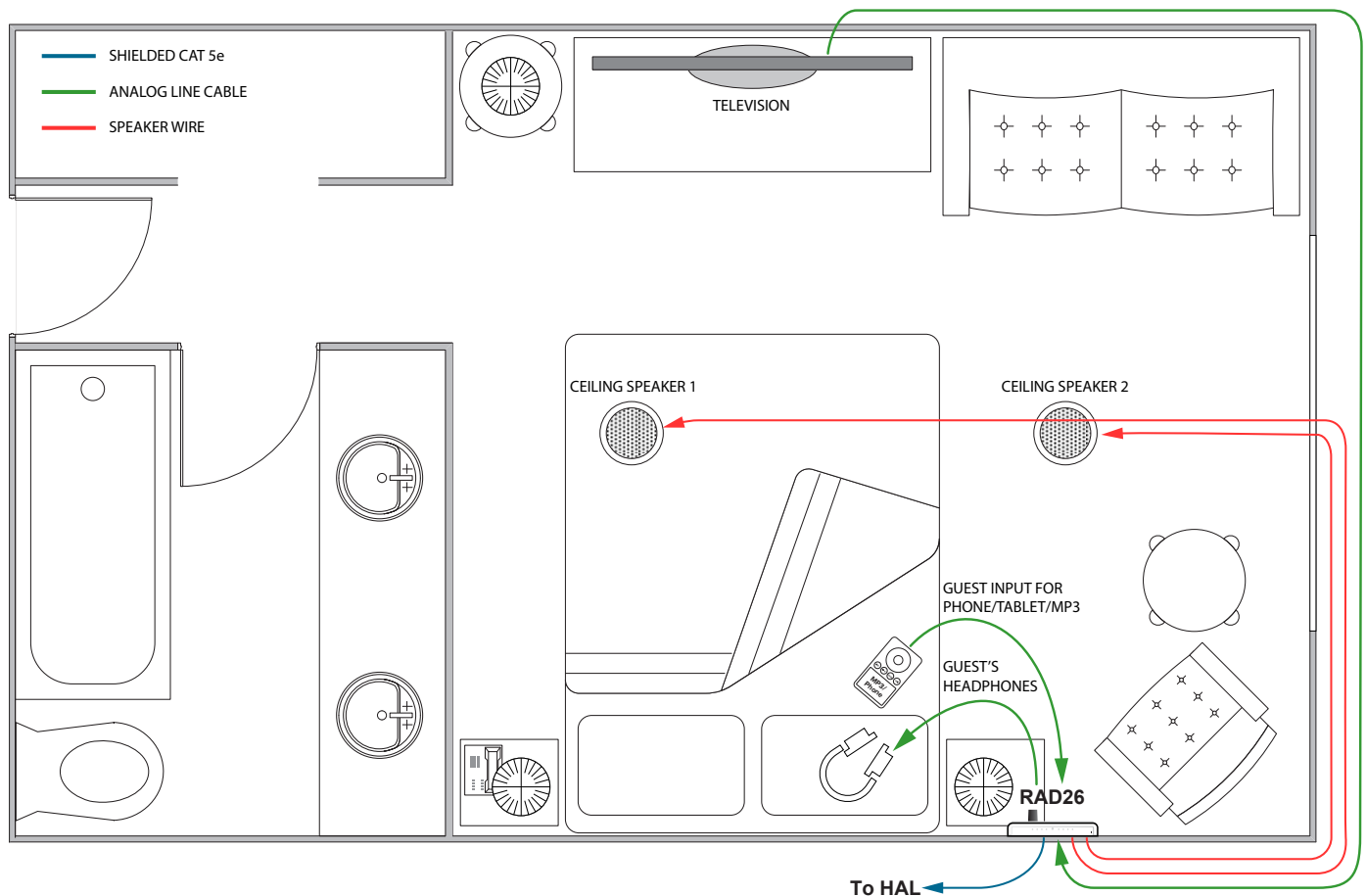

RAD26

ONE ROOM RAD REMOTE



RAD26 Massage Studio Application



This configuration provides a masseuse with easy and intuitive selection of either local or central background music sources and volume.

A desktop computer can supply audio to the rear of the RAD26 as a local background music source.

A masseuse can easily bring in a laptop, tablet, or smartphone connecting via a regular consumer stereo 3.5 mm cable to the AUX input. The RAD 26 can be configured so that inserting an AUX plug can override another music source.

Background music can be sent from a HAL multiprocessor elsewhere in the building. Emergency pages are always available and will override a local music selection.

The amplifier is set to dual 4 watt mode to drive the left and right speakers above the table.

You can add extra bass by connecting a line output to a powered subwoofer.

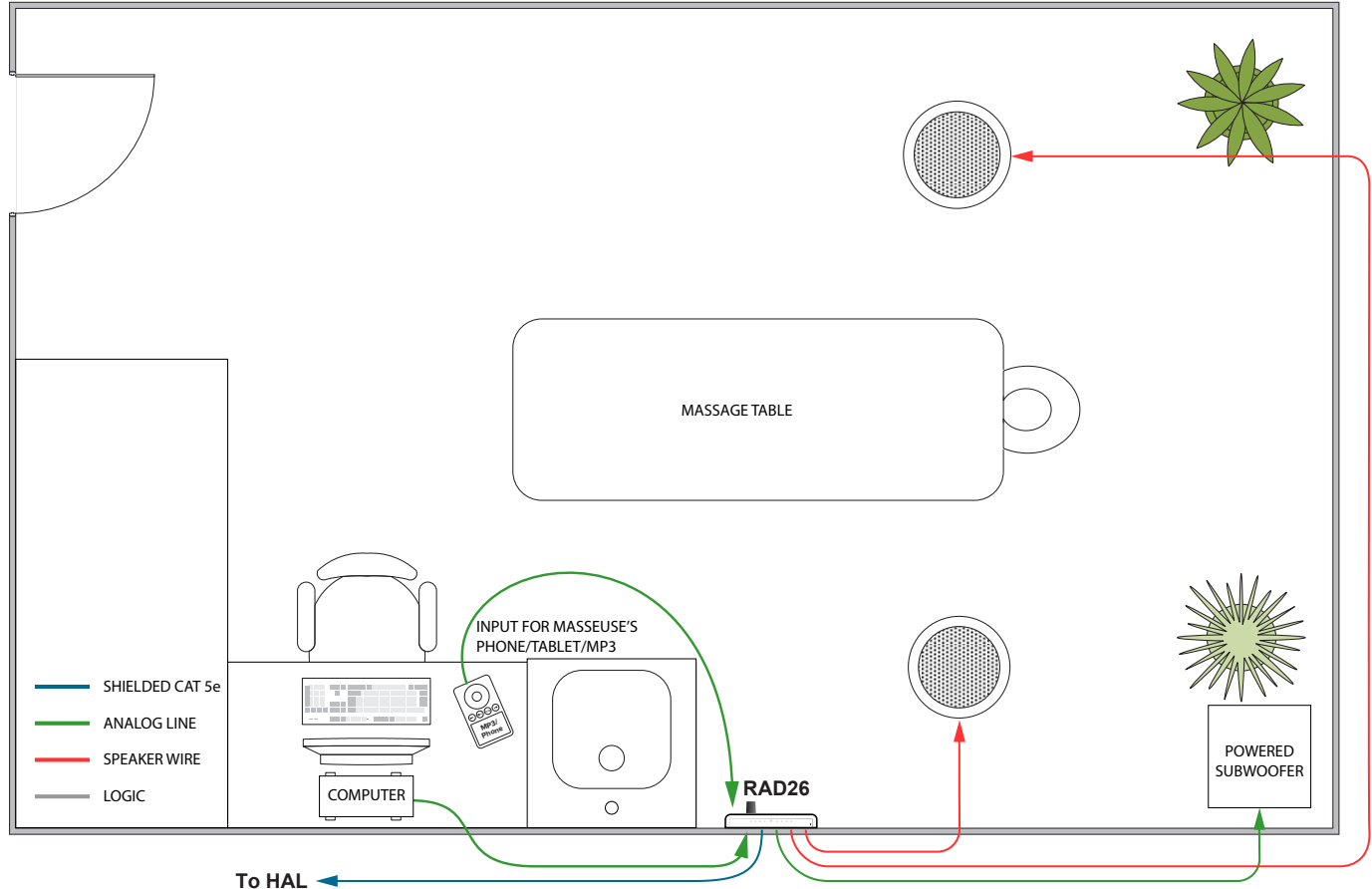

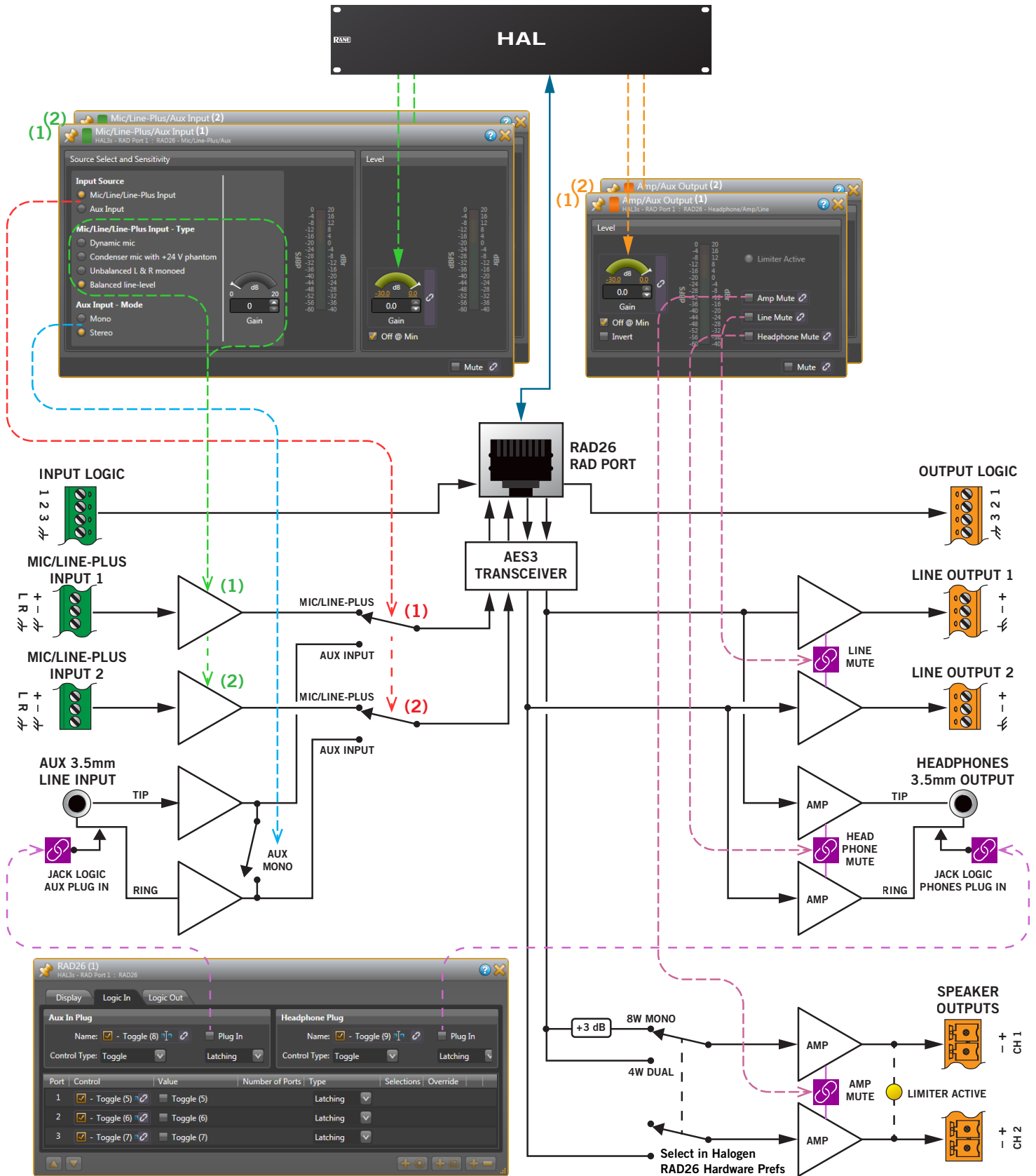
RAD26 Block Diagram

RAD26

ONE ROOM RAD REMOTE



RAD26 Rear Panel (attaches to wall mount bracket)

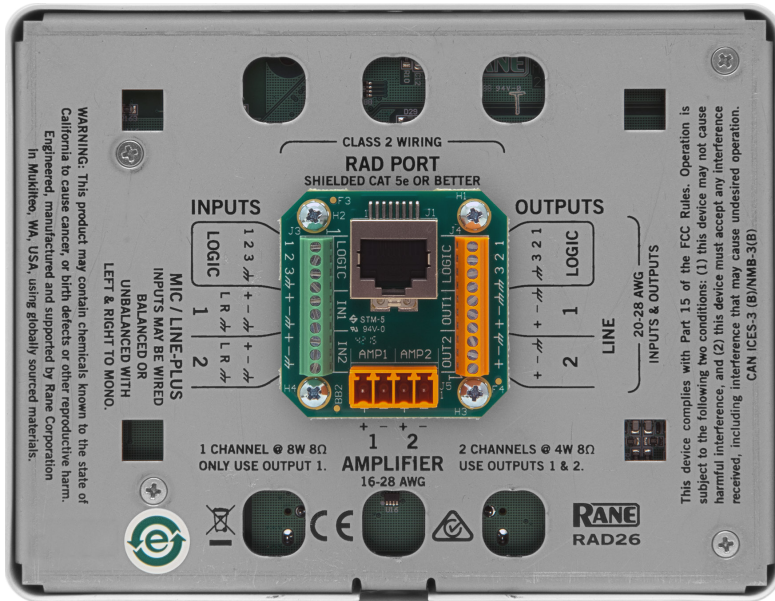

RAD26 Rear Wall Mount Bracket (included)

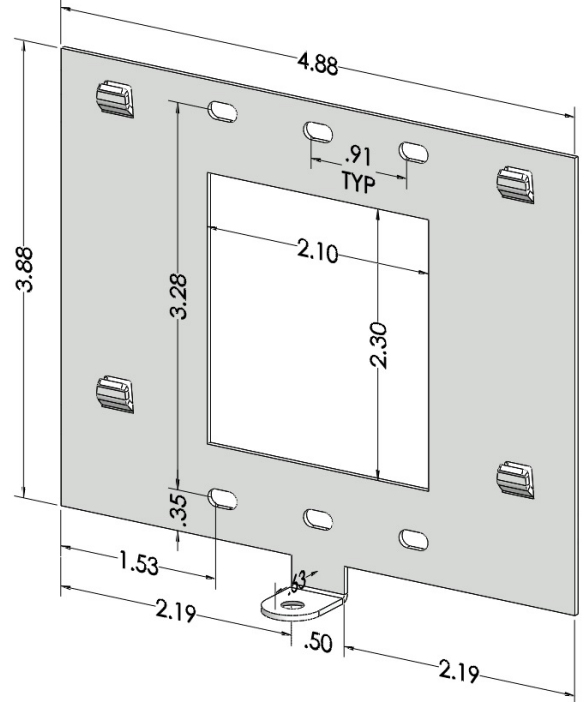

Includes RPI (Remote Power Injector)

The included midspan power injector (not PoE) connects shielded CAT 5e (or better) cables between any HAL and the RAD26 to deliver communications and the extra power needed for the display and amplifiers. The RPI is inserted anywhere between the HAL and the RAD26, which can be up to 100 meters (325 feet) apart. An IEC power cable is included.

Optional RB2 Rack Mount Accessory

The RAD26 and a round 4" speaker can mount in a 19" rack with this 3U black-painted metal panel. The RB2 was designed with the EIA 4" loudspeaker "standard" in mind, with a mounting bolt circle diameter of 120 mm, or 4.7" ±0.05".

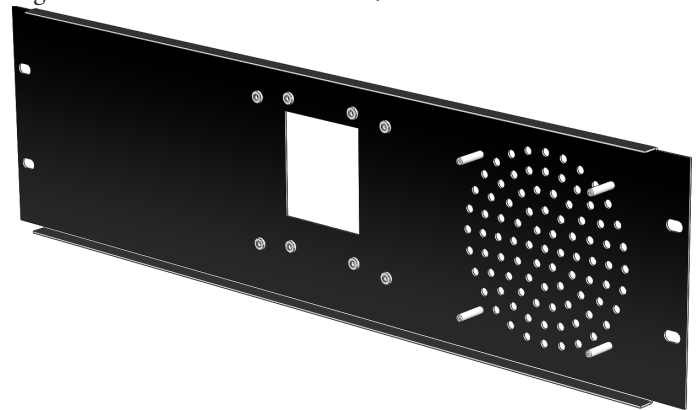
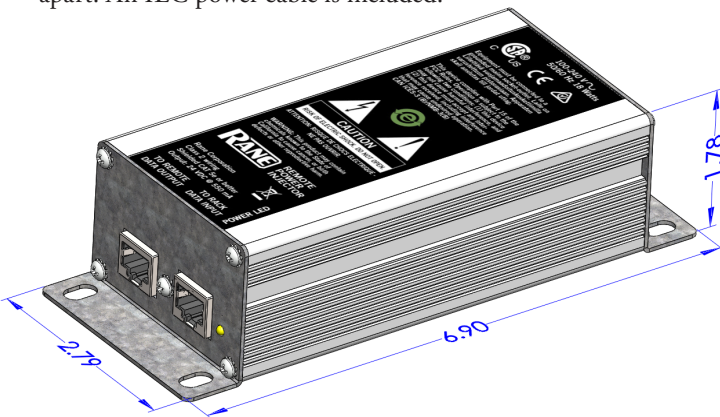

RAD26 Applications

Hotels with small meeting rooms and spa rooms require local inputs and control, but must also receive paging or music from elsewhere in the building. Many offices and campuses provide meeting and conference rooms for small groups with in-room A/V presentations, but must also receive emergency announcements. Other RADs and DRs can provide these functions, but require more than one shielded CAT 5 cable. The RAD26 provides all the features required in a single RAD.

General RAD Description

The entire family of RAD models interface with HAL for digital conversion at the wall. Each converts analog audio to and/or from 24-bit, 48 kHz digital audio. Shielded CAT 5e (or better) cable and termination transport four digital audio channels – two channels each direction – as well as power, ground and a communications channel, with status indicators at each RAD, HAL, or EXP unit, and in Halogen software. The host HAL auto-checks the CAT 5 crimp and verifies audio. All RADs are both "location-aware" and hot-swappable. Light sensors dim the RAD indicators in dark rooms.