



(61) 3051-5800

# DENON

## ***PROFESSIONAL***

# DN-312X

User Guide	English ( 2 – 5 )
Guía del usuario	Español ( 6 – 9 )
Guide d'utilisation	Français ( 10 – 13 )
Guida per l'uso	Italiano ( 14 – 17 )
Benutzerhandbuch	Deutsch ( 18 – 21 )
Appendix	English ( 22 – 23 )

## User Guide (English)

### Introduction

The DN-312X is an ultra-slim 1U rack-mounted 12-channel mixer with 6 mic/line combination inputs and 6 additional line inputs. It has balanced XLR outputs, a 1/4" (6.35 mm) mono output that can be used to connect the DN-312X to a remote mixer, a pair of RCA stereo outputs that can be used to connect to a remote recording device, and 1/4" (6.35 mm) mic monitoring port that can be used to monitor the mics' signals. The DN-312X provides individual volume control for all inputs in addition to volume control for the mono output port and a master volume control. It has a 3-level equalizer and a controlled priority for Mic/Line 1. It can be powered from standard AC or 24 V DC power source.

Please see this guide's [Setup](#) chapter to learn how to integrate DN-312X with your audio system.

### Box Contents

DN-312X

Power Cable

User Guide

Safety & Warranty Manual

### Support

For the latest information about this product (system requirements, compatibility information, etc.) and product registration, visit [denonpro.com](http://denonpro.com).

## Features

### Front Panel

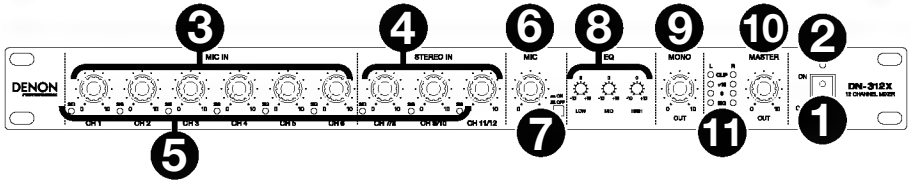

1. **Power Switch:** Use this switch to power DN-312X on or off.
2. **Power Light:** This light illuminates when DN-312X is powered on.
3. **Mic In Level:** Turn these knobs to set the input level of the corresponding **mic/line inputs** (Channels 1–6).
4. **Stereo In Level:** Turn these knobs to set the input level of the corresponding **line inputs** (Channels 7/8–11/12).
5. **Signal (Sig) Lights:** Indicates that the channel's incoming audio signal is within an optimal range.
6. **Mic Level:** Turn this knob to set the input level of the **Mic Monitor** output. Use the **Mic On/Off** button to enable to disable it.
7. **Mic On/Off:** Press this to turn enable or disable the **Mic Monitor** output. When the button is depressed (in the **down** position), the signal from the **mic/line inputs** (Channels 1–6) will be sent to the **Mic Monitor** output, and the **Line Outs** will be disabled. When the button is raised (in the **up** position), the **Mic Monitor** output will be disabled, and all channels will be sent to the **Line Outs**.
8. **EQ:** Turn these knobs to increase (“boost”) or reduce (“cut”) the amount of bass frequencies (**Low**), mid-range frequencies (**Mid**), and treble frequencies (**High**) of the main mix.
9. **Mono Level:** Turn this knob to adjust the level of the **Mono Out**.
10. **Master Level:** Turn this knob to adjust the level of the Line Outs, Mono Out, and Rec Out.
11. **Level Meters:** These lights indicate the audio level of the Line Outs, Mono Out, and Rec Out. The **Clip** light can light up occasionally, but if it happens too often, reduce the volume of the mix and/or individual channels.

Rear Panel

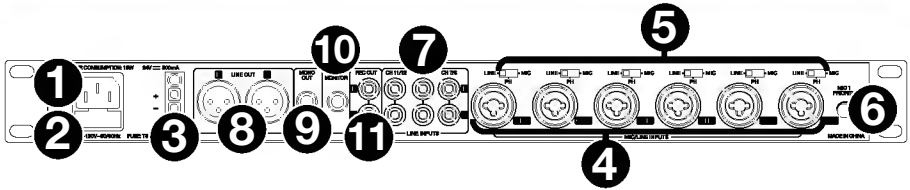

- AC Power Input:** Use the included power cable to connect this input to a power outlet. Alternatively, use the DC power input, described below. (If both power inputs are connected to power outlets, DN-312X will draw its power from the AC power input.)
- Fuse Cover:** If the fuse is broken, use a screwdriver or other tool to lift this tab, and replace the fuse with a fuse with the same rating. Using a fuse with an incorrect rating can damage the unit and/or fuse.
- DC Power Input:** Use a separate DC power supply to connect this input to a power outlet. Alternatively, use the AC power input, described above. (If both power inputs are connected to power outlets, DN-312X will draw its power from the AC power input.)
- Mic/Line Inputs (Channels 1–6):** Connect microphones or line-level devices to these inputs with XLR or 1/4" (6.35 mm) cables.
- Input Selector (Channels 1–6):** Use these switches to set what type of audio source is connected to each **mic/line input**: a microphone without phantom power (**Mic**), a microphone with +18–21V of phantom power (**Ph**), or a line-level device (**Line**).

**Note:** Most dynamic microphones do not require phantom power, while most condenser microphones do. Consult your microphone's documentation to find out whether it needs phantom power.

- Mic 1 Priority:** Turn this knob to set how loud the volume level of all other inputs will be when the Channel 1 **mic/line input** receives an incoming signal. At its lowest setting, a signal received by the Channel 1 **mic/line input** will mute all other input signals entirely. At its highest setting, a signal received by the Channel 1 **mic/line input** will not affect the other input signals at all.
- Line Inputs (Channels 7/8–11/12):** Connect line-level devices to these inputs with standard stereo RCA cables.
- Line Out:** Use standard XLR cables to connect these outputs to your loudspeakers or amplifier system. Use the **Master Level** knob to control the level of these outputs.
- Mono Out:** Use a standard 1/4" (6.35 mm) TS cable to connect this output to a remote recording device, remote mixer, etc. The signal sent from this output is a summed mono signal of the **line outs**.
- Mic Monitor:** Use a standard 1/4" (6.35 mm) cable to connect this output to a powered monitor, remote mixer, etc. When the **Mic On/Off** button is depressed (in the **down** position), the signal from the **mic/line inputs** (Channels 1–6) will be sent to this output, and the **Line Outs** will be disabled. When the **Mic On/Off** button is raised (in the **up** position), this output will be disabled, and all channels will be sent to the **Line Outs**.
- Rec Out:** Use standard stereo RCA cables to connect these outputs to a remote recording device, remote mixer, etc. Use the **Master Level** knob to control the level of these outputs.

## Setup

Items not listed under [Introduction > Box Contents](#) are sold separately.

### To set up DN-312X with your sound system:

1. If you are using any audio source with RCA outputs (Blu-ray® players, stereos, etc.), use standard RCA cables to connect them to the **line inputs** on the rear panel. Your audio sources must be line-level (no phono-level turntables).
2. If you are using microphones or other audio sources that send a line-level signal, connect them to the **mic/line inputs** on the rear panel.
3. Use standard XLR or 1/4" (6.35 mm) TRS cables to connect the **line outputs** on the rear panel to your loudspeakers, remote mixer, etc.
4. If you want to send the main mix to a remote recording device, remote mixer, etc., use a standard 1/4" (6.35 mm) TS cable to connect the **Mono Out** on the rear panel to it. Alternatively, use standard stereo RCA cables to connect the **Rec Outs** on the rear panel to it.
5. Use the included power cable to connect DN-312X to a power outlet.
6. Power on all of your audio sources (Blu-ray players, stereos, microphones, etc.).
7. Power on DN-312X.

### Example

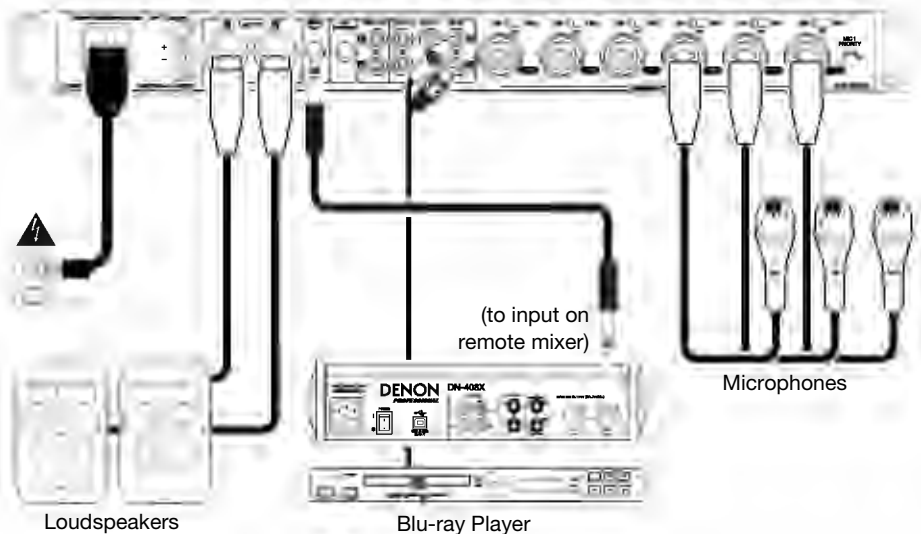

## Appendix (English)

### Technical Specifications

Input Channels	Mic/Line Inputs (Channels 1–6)	
	<b>Microphone Input</b>	XLR+1/4" (6.35 mm) combination, electronically balanced, discrete input configuration
	<b>Frequency Response</b>	20 Hz – 22 kHz ( $\pm 2$ dBu)
	<b>THD+N</b>	$\leq 0.03\%$ @ 1 kHz
	<b>Sensitivity</b>	-40 dBu
	<b>Maximum Input</b>	-19 dBu
	<b>Maximum Voltage Gain</b>	60 dB (Mic Input $\rightarrow$ Line Out, Mic Out & Mono Out) 50 dB (Mic Input $\rightarrow$ Rec Out)
	<b>Signal-to-Noise Ratio</b>	$\geq 103$ dB
	<b>Phantom Power</b>	+18–21 V, switch control
	Line Inputs (Channels 1–6)	
<b>Line Input</b>	XLR+1/4" (6.35 mm) combination, electronically balanced	
<b>Frequency Response</b>	20 Hz – 22 kHz ( $\pm 2$ dBu)	
<b>THD+N</b>	$\leq 0.03\%$ @ 1 kHz	
<b>Sensitivity</b>	0 dBu	
<b>Maximum Input</b>	+21 dBu	
<b>Maximum Voltage Gain</b>	20 dB (Mic Input $\rightarrow$ Line Out, Mic Out & Mono Out) 10 dB (Mic Input $\rightarrow$ Rec Out)	
<b>Signal-to-Noise Ratio</b>	$\geq 103$ dB	
Line Inputs (Channels 7/8–11/12)		
<b>Line Input</b>	Stereo RCA pairs, electronically balanced	
<b>Frequency Response</b>	20 Hz – 22 kHz ( $\pm 2$ dBu)	
<b>THD+N</b>	$\leq 0.03\%$ @ 1 kHz	
<b>Sensitivity</b>	+10 dBu	
<b>Maximum Input</b>	+21 dBu	
<b>Maximum Voltage Gain</b>	10 dB (Line Input $\rightarrow$ Line Out) 0 dB (Line Input $\rightarrow$ Rec Out) 4 dB (Line Input $\rightarrow$ Mono Out)	
<b>Signal-to-Noise Ratio</b>	$\geq 103$ dB	

<b>Impedance</b>	<b>Mic/Line Input</b>	1.4 k $\Omega$
	<b>Line Input</b>	$\geq 10$ k $\Omega$
	<b>All Outputs</b>	120 $\Omega$
<b>Equalizer</b>	<b>High</b>	$\pm 15$ dB @ 12 kHz
	<b>Mid</b>	$\pm 12$ dB @ 2.5 kHz
	<b>Low</b>	$\pm 15$ dB @ 80 Hz
<b>Crosstalk</b>	<b>Adjacent Inputs</b>	$\leq -70$ dB @ 1 kHz (Channels 1–6) $\leq -68$ dB @ 1 kHz (Channels 7/8–11/12)
	<b>Input <math>\rightarrow</math> Output</b>	$\leq -82$ dB @ 1 kHz (channel level @ max., EQ @ unity, master level & others @ min., input selectors set to <b>Line</b> )
<b>Main Mix</b>	<b>Line Output</b>	0 dBu (+2 dBu), balanced (channel level, master level & EQ @ unity, all others at min., input selectors set to <b>Line</b> )
	<b>Mic Output, Mono Output</b>	0 dBu (+2 dBu), unbalanced (channel level, master level & EQ @ unity, all others at min., input selectors set to <b>Line</b> )
	<b>Maximum Output</b>	+21 dBu balanced/unbalanced, 1/4" (6.35 mm) jacks
	<b>Noise (Bus)</b>	< -83 dB @ 20 Hz – 22 kHz (channel level, master level & EQ @ unity, all others at min., input selectors set to <b>Line</b> )
<b>Power</b>	<b>Connection:</b> IEC <b>Input Voltage:</b> 100V~, 110-120V~, 50/60Hz; 220-240V~, 50/60Hz or DC24V	
<b>Dimensions</b> (width x depth x height)	19.0" x 7.7" x 1.7 " 483 x 195 x 44 mm	
<b>Weight</b>	6.4 lbs. 2.9 kg	

Specifications are subject to change without notice.

## Trademarks & Licenses

Denon is a trademark of D&M Holdings Inc., registered in the U.S. and other countries.

Blu-ray™ and the logo are trademarks of the Blu-ray Disc Association.

All other product or company names are trademarks or registered trademarks of their respective owners.