



BELLA 22

22 AUDIO INPUT NETWORK AUDIO MONITOR

PRODUCT DETAILS





GlenSound Electronics Ltd

Thank you for choosing a new GlenSound product.

All rights reserved.

Information contained in this manual is subject to change without notice, if in doubt please contact us for the latest product information.

If you need any help with the product then we can be contacted at:

GlenSound Electronics Ltd
1 – 6 Brooks Place
Maidstone
Kent
ME14 1HE
United Kingdom

Telephone: +44 (0) 1622 753662

Fax: +44 (0) 1622 762330

EMAIL ADDRESSES

General enquires: office@glenSound.co.uk

Technical enquires: techinfo@glenSound.co.uk

Sales enquires: sales@glenSound.co.uk

PRODUCT WARRANTY:

All equipment is fully tested before dispatch and carefully designed to provide you with trouble free use for many years.

We have a policy of supporting products for as long as possible and guarantee to be able to support your product for a minimum of 10 years.

For a period of one year after the goods have been despatched the Company will guarantee the goods against any defect developing after proper use providing such defects arise solely from faulty materials or workmanship and that the Customer shall return the goods to the Company's works or their local dealer.

All non-wear parts are guaranteed for 2 years after despatch and any defect developing after proper use from faulty materials or workmanship will be repaired under this warranty providing the Customer returns the goods to the Company's works or their local dealer.



EU DECLARATION OF CONFORMITY FOR:

BELLA 22

22 Input Network Audio Monitor

This declaration of conformity is issued under the sole responsibility of the manufacturer.

This equipment is manufactured by Glensound Electronics Ltd of Brooks Place Maidstone Kent ME14 1HE is  marked and conforms to the following Union harmonisation legislation:

Low Voltage Directive:	EN60065 and EN62368-1:2014
Emissions:	BS EN55032:2015
Immunity:	BS EN55035:2017

Signed for and on behalf of Glensound Electronics Ltd.

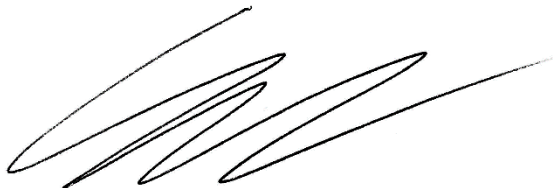

Gavin Davis, Managing Director
Maidstone, Kent, England

Date: 18/01/2019

RoHS DIRECTIVE

RoHS 2 Directive 2011/65/EU restricts the use of the hazardous substances listed below in electrical and electronic equipment.

This product conforms to the above directive and for these purposes, the maximum concentration values of the restricted substances by weight in homogenous materials are:

Lead	0.1%
Mercury	0.1%
Hexavalent Chromium	0.1%
Polybrominated Biphenyls	0.1%
Polybrominated Diphenyl Ethers	0.1%
Cadmium	0.01%

WASTE ELECTRICAL AND ELECTRONIC EQUIPMENT REGULATIONS 2006 (WEEE)

GlenSound Electronics Ltd is registered for business to business sales of WEEE in the UK our registration number is:

WEE/JJ0074UR

GLENSOUND BELLA 22

Handbook Contents

Issue 1

Description

Page No.

Contents

PRODUCT WARRANTY:	3
OVERVIEW	8
BELLA 22 PANEL LAYOUT	9
Front Panel	9
Front Panel Features.....	9
Rear Panel	13
Rear Panel Features	13
AUDIO BLOCK DIAGRAM	15
Analogue Representation	15
Mix Busses.....	16
CONNECTING THE BELLA 22 TO A DANTE® NETWORK	17
Getting Dante Controller	17
Connecting Bella 22 To The Network	17
Audio Over IP Network.....	17
Running Dante Controller	18
Dante Controller TIP	19
Device Not Showing Up In Dante Controller.....	19
AES67 MODE.....	20
UPDATING THE BROOKLYN CHIPSET	22
SPECIFICATIONS	23
WIRING INFORMATION	24
Standard XLR Pin Outs.....	24
Standard Headphone Wiring.....	24
D9 Wiring & Loop Interconnecting To External Equipment	25

OVERVIEW

Bella 22 is a 2 buss summing matrix confidence monitor designed for outside broadcast trucks, studios, theatre and professional audio applications. It is perfect for easy and cost effective monitoring of multiple network audio sources, ideal for busy production environments and perfect for monitoring multiple network intercom & programme feeds.

10 front panel volume controls can each control one or two network audio inputs and the output of each of these controls can be routed to the left or right mix busses. In addition to the 20 network audio inputs 2 analogue inputs are also provided for added versatility.

10 front panel channel on/ solo switches are also provided enabling sources to easily be turned on/off the loudspeaker monitoring mix, or soloed to this mix if required. In addition to the LS monitoring mix there is a 2nd mix buss that provides a permanently on mix output from the 10 input circuits.

There are 32 network audio outputs in total. 20 of which are the 20 network audio inputs taken directly after the front panel level controls. 6 are from the mix buss taken after the solo/ channel on switches and the final 6 are from the 2nd mix buss that is before the mix/ solo switches.

As well as the network audio outputs 3 line level analogue outputs are provided and an AES3 output, these follow the switched/ solo mix buss.

The 2 front panel loudspeakers are driven from a DSP to compensate for their size, the result is surprisingly good, with clear crisp vocals and highly intelligible reproduction of wider band audio sources. They are driven from a class D amplifier and have more than sufficient output level for most environments.

The name Bella comes from a common English phrase 'Listen To Your Mother' which as a child often means that you're in trouble!

Dante Alighieri's mother was Bella Abati.

We therefore hope that if you listen to our Bella 22 it will keep you out of trouble.

BELLA 22 PANEL LAYOUT

Front Panel

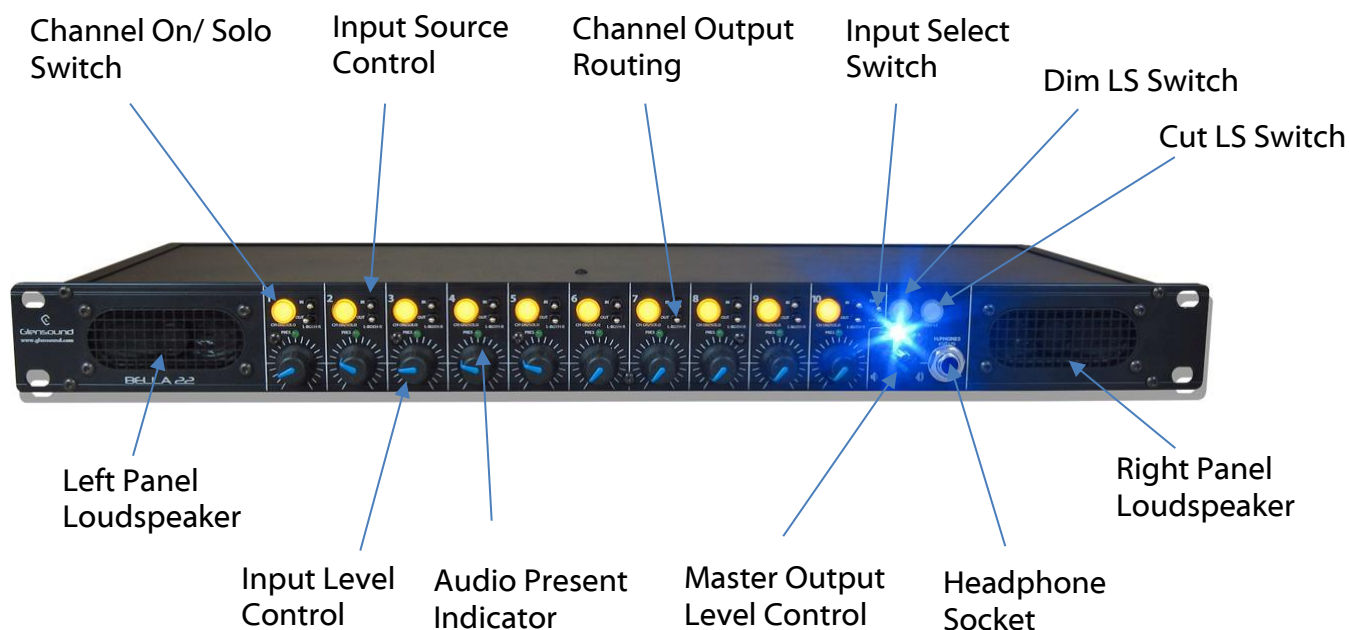

Front Panel Features

1. Channel On/ Solo Switch

These 10 round yellow illuminated switches turn the input of the associated channel on/ off the loudspeaker, analogue, AES3 and mix/ solo network audio outputs.

Pressing and holding one of these switches will solo its channels output to the loudspeaker, analogue, AES3 and mix/ solo network audio outputs.

2. Input Source Control

Each of the 10 input channels has 2 network audio sources associated with it. These appear in Dante controller as the channel number followed by 'L' (left) or 'R' (right).

The source input control is a 3 position toggle switch. Moving it left will route just the left audio input to the channels output routing switch, moving it right will route just the right audio input to the channels output routing switch and in its central position both left and right inputs will be sent to the channels output routing switch.

3. Channel Output Routing

The output routing control is a 3 position toggle switch. It will route the selected input(s) to the left/ right or both (left & right) mixes. The selected input (left/ right channel) has a bearing on what is actually routed to the mix circuits.

The table below shows the relationship between selected inputs to routed outputs.

SWITCH SETTINGS	Left Input	Both Inputs	Right Input
Left Out	<i>Left input routed to Left output only</i>	<i>Left & Right inputs mono'd and routed to Left output only</i>	<i>Right input routed to Left output only</i>
Both Out	<i>Left input routed to both Left & Right outputs</i>	STEREO <i>Left input routed to Left output and Right input routed to Right output</i>	<i>Right input routed to both Left & Right outputs</i>
Right Out	<i>Left input routed to Right output only</i>	<i>Left & Right inputs mono'd and routed to Right output only</i>	<i>Right input routed to Right output only</i>

4. Input Select Switch

The 10th input channel has the option of taking its left & right audio inputs either from the Dante/ AES67 audio network OR from a pair of local analogue audio inputs on the rear of the unit.

5. Dim Switch

When used this illuminated switch will dim both the front panel loudspeakers and the analogue and AES3 outputs. It will also dim any of the network output circuits that are after the dim control.

A rear panel GPI circuit also affects the state of this switch. If the rear GPI circuit is made (i.e. on) then the switches internal LED will illuminate and pressing the switch will not turn the dim on or off.

6. **Cut LS Switch**

When used this illuminated switch will cut both the front panel loudspeakers and the analogue and AES3 outputs. It will also cut any of the network output circuits that are after the cut control.

A rear panel GPI circuit also affects the state of this switch. If the rear GPI circuit is made (i.e. on) then the switches internal LED will illuminate and pressing the switch will not turn the cut on or off.

There is a 2nd rear panel GPI circuit that can be used to cut just the internal loudspeakers. If this 2nd GPI circuit is made (i.e. on) then the internal loudspeakers will be cut but the switches internal LED will not be on and this switch will continue to operate a cut on the analogue, AES3 and network outputs.

7. **Left Panel Loudspeaker**

This internal loudspeaker is fed audio from the left output of the mix/ solo mix buss. The front panel overall level control adjusts its volume and the front panel Cut & Dim switches also affect it.

There is a rear panel GPI that can turn the internal loudspeakers off.

Inserting a headphone jack in the headphone socket also turns the loudspeaker off.

8. **Input Level Control**

The level control adjusts the incoming audio level by applying gain/ loss to it. In its 12 O'clock position it is at unity gain.

Fully clockwise 10.6dB of gain will be applied to the input.

Fully anti-clockwise 30dB of loss will be applied to the input.

9. **Audio Present Indicator**

The 'PRES' (present) LED indicates to show that valid audio is being detected on the channel prior to the level control.

It will illuminate when an incoming audio circuit is at -20dBu or above.

Once illuminated it will stay illuminated for 3 seconds after it detects the input level to fall below -20dBu.

If the Led Flashes this indicates that the input level is either clipping or within 1dB of clipping.

10. **Master Output Level Control**

This volume control adjusts the overall output level of the unit. It adjusts the level to the internal loudspeakers, headphones, analogue outputs, AES3 output and the network audio outputs that are affected by it.

In its 12 O'clock position it is at unity gain.

Fully clockwise 10.6dB of gain will be applied to the output.

Fully anti-clockwise 30dB of loss will be applied to the output.

11. **Headphone Socket**

This 6.35mm (1/4") tip ring sleeve (TRS) jack socket provides a stereo output for monitoring the mix/ solo buss.

Inserting a jack into this socket will cut the internal LS, the analogue and AES3 audio outputs and any network audio outputs affected by the cut circuit.

It is suitable of use with headphones with impedances of 100 – 2000 Ohms.

12. **Right Panel Loudspeaker**

This internal loudspeaker is fed audio from the right output of the mix/ solo mix buss. The front panel overall level control adjusts its volume and the front panel Cut & Dim switches also affect it.

There is a rear panel GPI that can turn the internal loudspeakers off.

Inserting a headphone jack in the headphone socket also turns the loudspeaker off.

Rear Panel

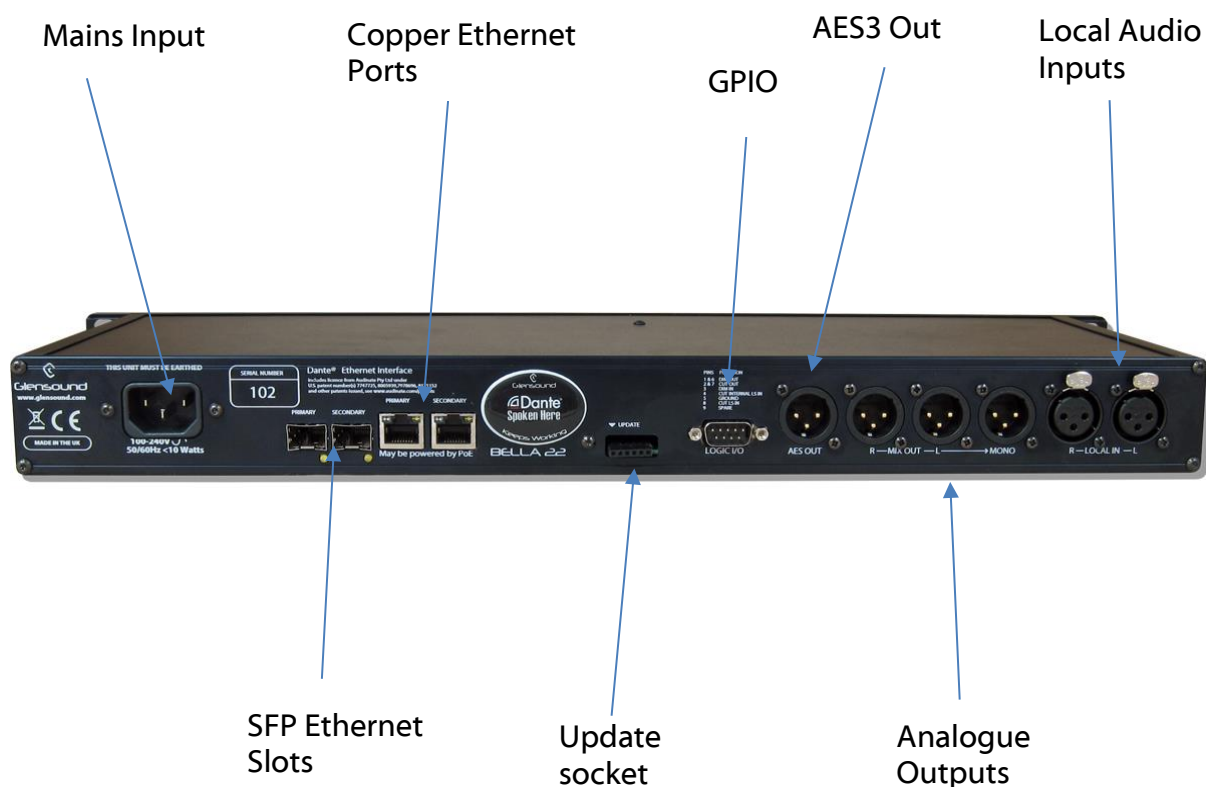

Rear Panel Features

13. Mains Input

The standard IEC mains plug is filtered and accepts external AC voltages of 100 -240 VAC +/- 10%.

There is an internal fuse and maximum current consumption is 10 Watts.

14. Copper Ethernet Ports

These 2 copper RJ45 Ethernet ports can accept standard network cables. Only one port is required to be connected to your network to correctly pass Dante®/ AES67 network audio, however both the primary and secondary ports can be used if a redundant network topology is in use.

Both ports are gigabit Ethernet and the LEDs flash to indicate data is being correctly communicated with a switch.

15. **GPIO**

This 9 pin D plug provides access to the GPIO (General Purpose Inputs & Outputs) circuits. These are useful for connecting to external devices such as red light systems.

Please see the wiring section of this handbook for more details.

16. **AES3 Output**

The AES3 output is an output of the mix/ solo buss' left & right channels. This circuit's sample frequency is 48kHz and it is driven as a direct output from the internal DSP.

17. **Local Audio Inputs**

The local audio input XLRs are both balanced analogue with a line up of 0dBu. They are electronically balanced and their inputs can be wired unbalanced.

Their audio input is fed into the mix busses via input channel's 10 'Dante/ Local' toggle switch. The switch needs to be in the 'Local' position for the outputs of these audio inputs to be fed into the mix buss.

18. **SFP Ethernet Slots**

These 2 SFP Ethernet slots can accept most standard SFP (GBIC) modules. Only one port is required to be connected to your network to correctly pass Dante®/ AES67 network audio, however both the primary and secondary ports can be used if a redundant network topology is in use.

Both ports are gigabit Ethernet and the LEDs flash to indicate data is being correctly communicated with a switch.

19. **Update Socket**

The update socket is used by a Glensound authorised engineer in the unlikely event that new internal microprocessor code is required to be installed in the Bella 22. The internal microprocessor is a PIC.

20. **Analogue Output XLRs**

3 analogue output XLRs are provided, marked as 'Mix Out', 'R' (right), 'L' (left) & 'Mono'. These are line level electronically balanced analogue audio circuits with a nominal line level of 0dBu. Being electronically balanced they can be wired unbalanced if required.

The audio being routed to these circuits is the output of the Mix/ Solo mix buss and they are affected by the Cut and Dim LS circuits and the overall level control.

AUDIO BLOCK DIAGRAM

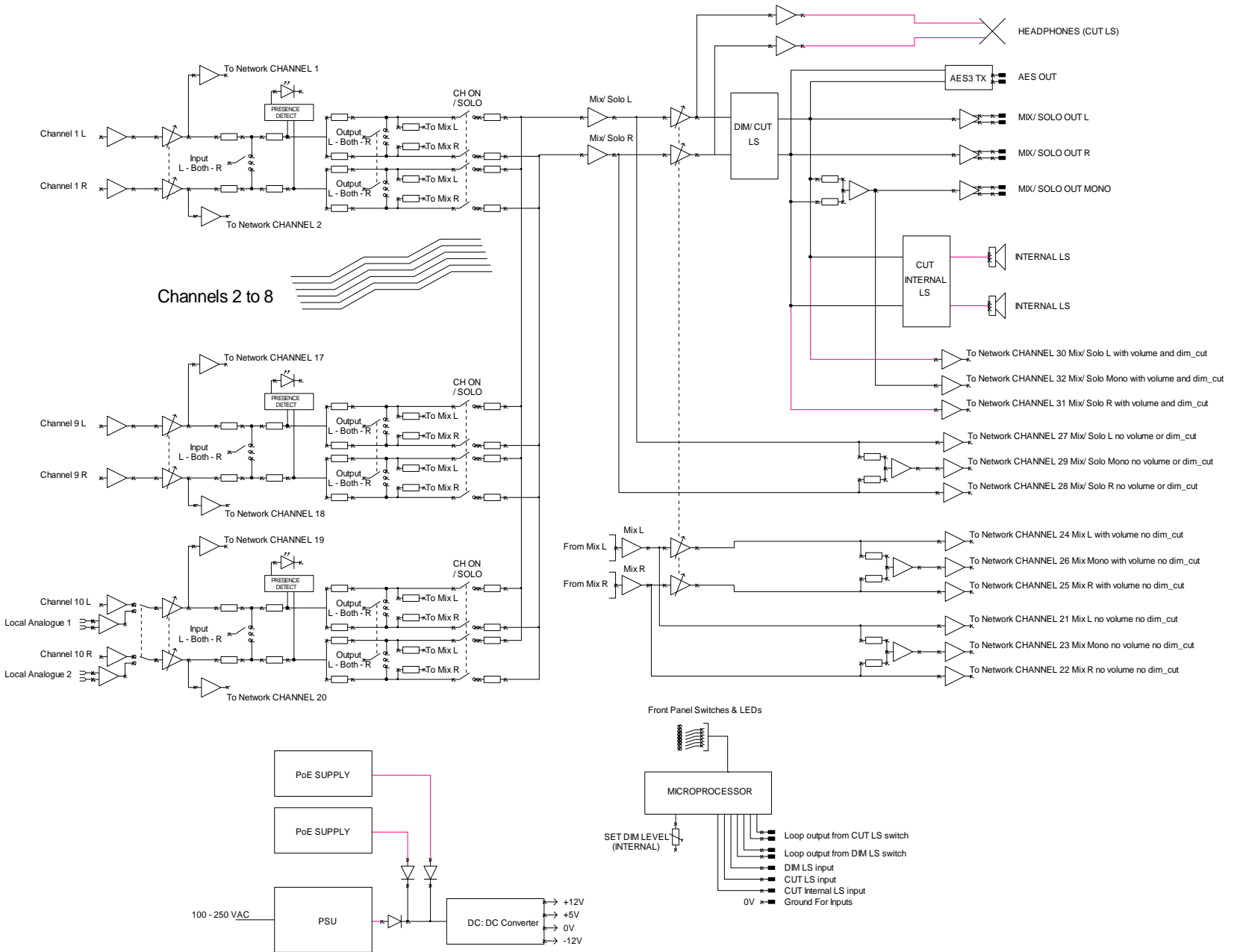

Analogue Representation

The above diagram is drawn as an analogue audio workflow, however the Bella 22 is a digital device and most functions are actually performed in the digital domain.

Mix Busses

There are two main stereo mix busses within the Bella 22. These are referred to as 'MIX/ SOLO' or just 'MIX'.

In simple terms the 'MIX/ SOLO' outputs are derived after the front panel Channel On/ Solo buttons. If a channels on switch is off its output will not be sent to the MIX/ SOLO buss. If the soloing feature is used (i.e. a front panel solo button held down) then the MIX/ SOLO buss will output just the solo'd channels audio.

The 'MIX' outputs are a permanently on mix. The front panel Channel On/ Solo buttons do NOT affect this mix, all 10 inputs are always fed into this mix buss.

The MIX outputs are only available as network audio outputs and are available either pre or post the master volume control (no volume or with volume) control. The LS dim or cut circuits never affect these outputs.

The MIX/ SOLO outputs are routed to the analogue and AES3 outputs which are always post the master volume control and also always affected by the dim and cut circuits. There are also 2 sets of this mix routed to the network outputs, 1 set is post master volume, dim & cut and the 2nd set is pre master volume, dim & cut.

CONNECTING THE BELLA 22 TO A DANTE® NETWORK

The Bella 22 is a network audio devices utilizing the reliable and versatile Dante® audio over IP protocol. Dante® is a proprietary system (although very widely used) the originators of which are Audinate.

The information below is only meant as a very basic guide. Full details of the power of Dante network audio and instructions for using it can be found at

www.audinate.com

Getting Dante Controller

If you are connecting the Bella 22 to a new Dante network the first thing you will need to do is to get the free Dante controller software from Audinate.

This can be downloaded by visiting Audinate's web site at www.audinate.com

Connecting Bella 22 To The Network

Bella 22s can be connected to the network that you are going to use for your audio distribution simply by plugging in either, and, or any of the network connections on the rear. Once connected to the network it will be possible to see the Bella 22 from within the Dante controller and route its' audio circuits.

Audio Over IP Network

We strongly recommend that you consider your network topology carefully and would not recommend sharing broadcast audio and general data on the same network.

For more details of audio over IP network structure please visit www.audinate.com

Running Dante Controller

At the time of writing this manual the Dante Controller looks as per the screenshot below:

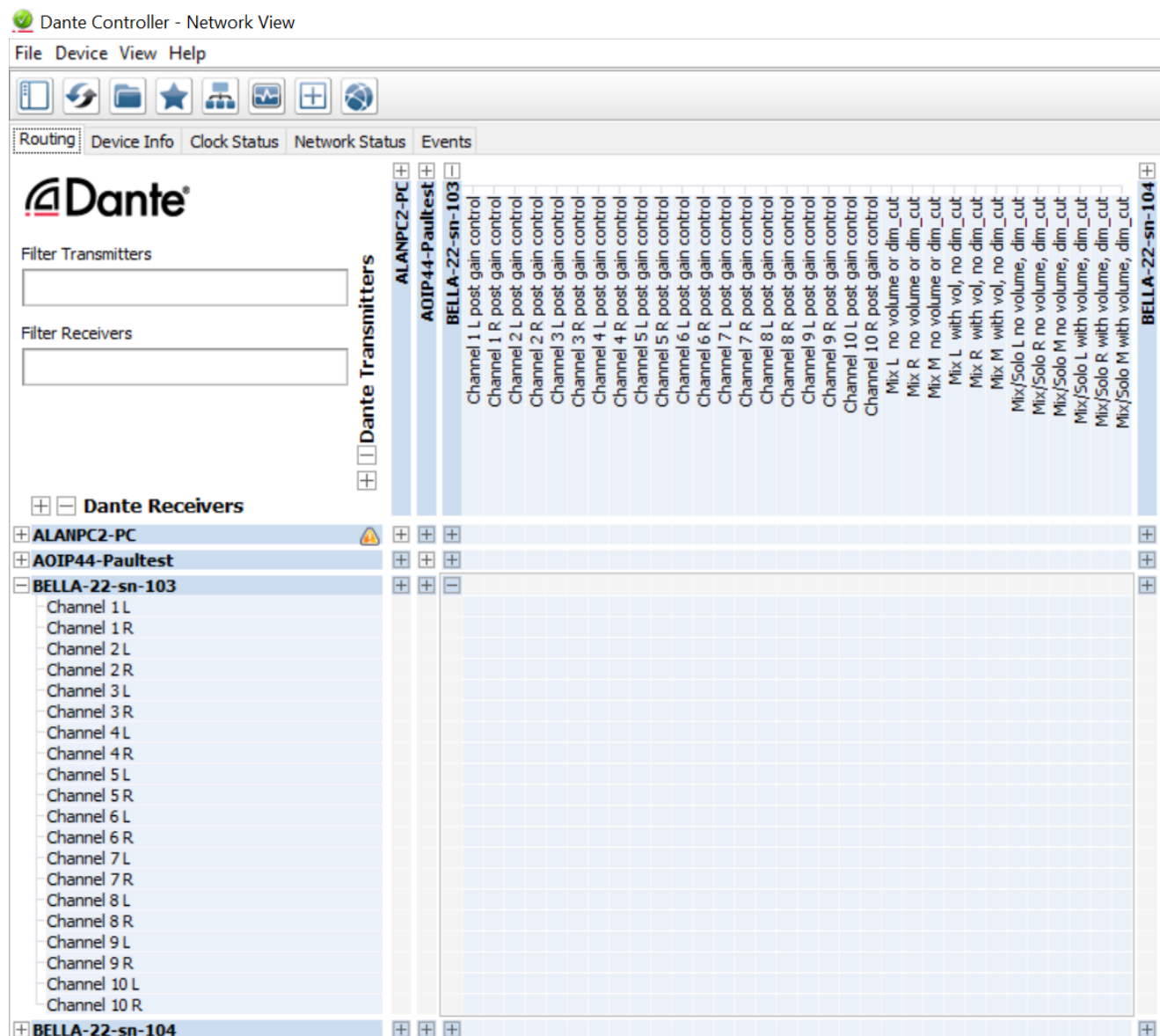

The Bella 22 will have been named at the factory during test to allow them to be identified by the Dante controller.

The format used for the factory name is:

'BELLA-22-sn-XXX'

The '-sn-XXX' refers to the serial number of the Bella 22 unit which can be found printed on the rear of the unit.

Note if you upload a new DNT file or clear the devices config then the name will change to Bella 22XX-xxXxXx whereby the 'X's refer to the devices MAC address.

Dante Controller TIP

If you have never run Dante controller before then make sure that on the bottom left of the Dante controllers' screen 'P' or 'S' is next to a green square as this indicates that it is connected to a network. By clicking 'P' or 'S' a pop up box opens to allow you to set what network interface the controller is using.

Device Not Showing Up In Dante Controller

If your Dante® device does not show up in Dante® Controller then the most likely issue is that the device's IP Address is not appropriate for your network.

- A) It maybe that the device is set to obtain an IP address automatically using DHCP (this is the default configuration) and your network is setup for fixed IP addresses only and does not have a DHCP server.
- B) It maybe that the device has had a fixed IP address assigned but that this address is not suitable for your network.

The solution to both scenarios is basically the same.

- 1) You must connect your Dante® device directly to the Ethernet port of your computer using an Ethernet cable.
- 2) Make sure that your computer is set to 'Obtain an IP address automatically'
- 3) After a few minutes the Dante® device should now appear in Dante® Controller.
- 4) Double click the device name to open up device view.
- 5) Open up the 'Network Config' tab
- 6) Either turn on 'Obtain an IP Address Automatically' or correctly configure the 'Manually configure an IP Address' options for your network.
- 7) Click on 'Apply' to confirm the new settings, then disconnect the computer and reconnect the Dante® device to your network.

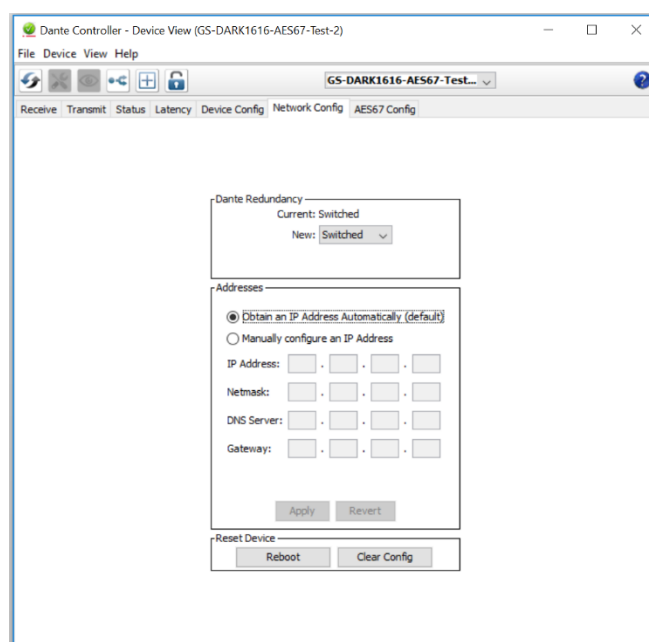

AES67 MODE

The Bella 22 uses a Brooklyn 2 module from Audinate for its network audio interface. Audinate are the company behind Dante® and as such the module's primary network audio protocol is Dante, however Audinate have enabled their module to comply with AES67 and therefore the Bella 22 can be set to AES67 mode for interaction with other AES67 devices.

Please note however that Glensound are relying on Audinate's AES67 interface and are unfortunately not able to provide full AES67 support for the unit. AES67 support should be sought directly from Audinate.

1. Turning On AES67 Mode

If you want to use your Bella 22 on an AES67 network and it has not been set to AES67 mode then this can be set in Dante controller by double clicking the Bella 22 to open the Device View window where you will find an AES67 tab to enable AES67 support.

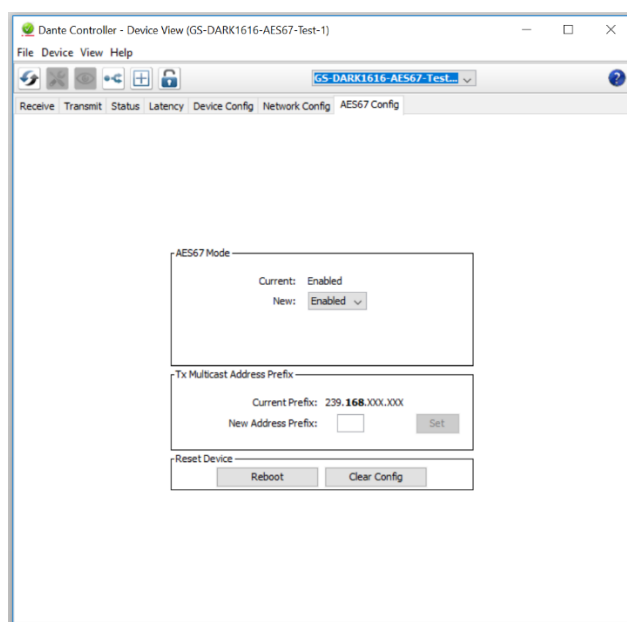

Once the AES67 drop down box has been enabled you'll have to reboot the Bella 22 for the change to take effect. After the reboot go back to the AES67 tab and set the multicast prefix address to one that is suitable for your network.

2. Sending AES67 Audio

To transmit AES67 audio to the network a multicast flow must first be setup.

This is done by selecting the 'Create New Multicast Flow' Icon  in the Device View.

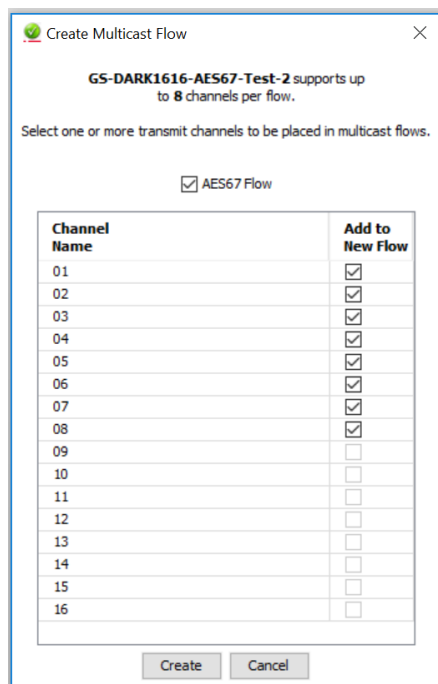

Tick the AES67 Flow check box, then select up to 4 channels to be included in the flow then click 'Create'

Once set the flows can be seen in the transmit tab of the device view.

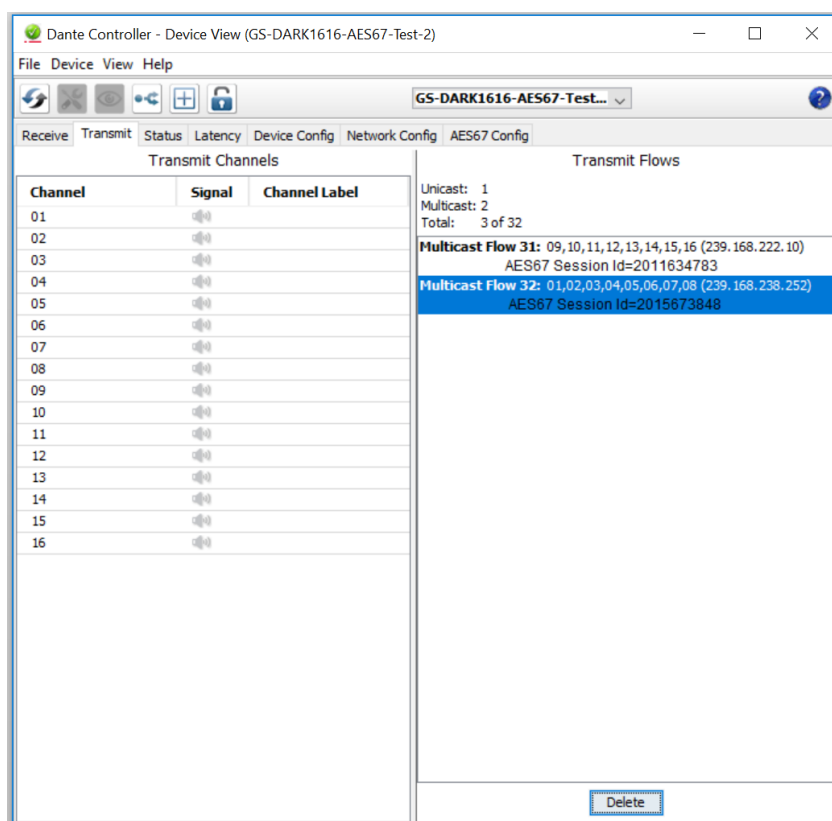

UPDATING THE BROOKLYN CHIPSET

The Brooklyn module is a device supplied by Audinate that does most of the processing for the actual Dante/ AES67 network audio streams. There is one Brooklyn module in each Bella 22. We supply special code (a .dnt file) that sets up/ initiates the Brooklyn module and makes it work in particular way that is compatible to the Bella 22.

1. Finding Out Current Installed Version

Using Dante® controller double click on the Bella 22 device name in the routing tab to open the Device View box.

In the Device View box open the Status Tab.

The 'Product Version:' shows the currently installed version of Brooklyn module dnt code.

2. Finding Out What The Latest Available Version Is

Go the Bella 22's web and open the 'Firmware Latest Version' Tab.

This will give both the latest version numbers/ file names and also the location to download the file from.

3. Updating the Brooklyn module

The firmware that runs in the Brooklyn module is updated using Audinate's Firmware updating tool. The updating tool and a user guide can be downloaded from Audinate's website:

<https://www.audinate.com/products/firmware-update-manager>

NOTE:

Please note we strongly advise that when you do the update that only your PC and the Bella 22 that you want to update are on the network to save accidentally updating the wrong Dante device.

SPECIFICATIONS

AUDIO

Channel Input Gain Controls

+10.6 to -31dB

Loudspeaker/ Headphone Gain Control

+10.6 to -31dB

Channel Off Switch

Fully muted (- infinity dB) when off

Channel Input Select Switch

Left Ch Only, Right Ch Only, Both Chs (Stereo)

Channel Output Routing Switch

Left Ch Only (Selected Inputs mono'd)

Right Ch Only (Selected Inputs mono'd)

Both Channels (Stereo if Both Chs I/Ps selected)

Analogue Input Type

Electronically balanced

(can be wired unbalanced)

Analogue Input Impedance

>20kOhms

Analogue Input Connectors

Neutrik XLRs

Analogue Input Line Up

Line level (0dBu)

Analogue Input Frequency Response

>= 0.5dB 22Hz to 22kHz

Measured at Mix Output Mono

Analogue Input THD + Noise (ref +8dBu)

>= 0.004% @ 1kHz

Analogue Output type

Electronically balanced

Analogue Output Connectors

Neutrik XLRs

Analogue Output Impedance

+<50 Ohms

Maximum Analogue Output Level

+17.4dBu

Analogue Output Frequency Response

>= -0.1dB 22Hz to 22kHz

Analogue Output Noise

-91dB @ lineup (residual noise)

Analogue Out THD + Noise (ref =8dBu)

0.002% @ 1kHz

Headphone Impedance

100 - 1000 Ohms

Maximum Headphone Level

+17dBu into 600 Ohms

Present LED Threshold

-20dBu

Present LED Hold Time

3 seconds

Present LED Clip Indication

Flashes when within 1dB of clip point

SIZE & POWER

Dimensions

19" wide 1RU high 164mm deep (chassis)

Weight

1740g

Mains Input

100 to 240VAC 50/60Hz

Power Consumption

<10 Watts

PoE (Power Over Ethernet)

Maybe powered by standard PoE on either copper network interface

Shipping Weight

4Kg

Shipping Carton

Export quality cardboard carton

62 x 41x 12 cms

INCLUDED ITEMS

Rj45 Cable

1 x 2M Rj45 network cable

Handbook

A4 user guide (download also available)

Mains Cable

1 x IEC Mains cable

(UK & Europe Only)

NETWORK AUDIO

Network Protocol

Dante®

AES67

Compliant

DDM

Certified

Full Scale

0dBu = -18dBfs

Sample Frequency

48kHz

Resolution

24 Bit

Network Interface Type

Gigabit Ethernet

Network Interface Physical

2 x Rj45 copper

2 x SFP Slots (SFP Modules Not Included)

WIRING INFORMATION

Standard XLR Pin Outs

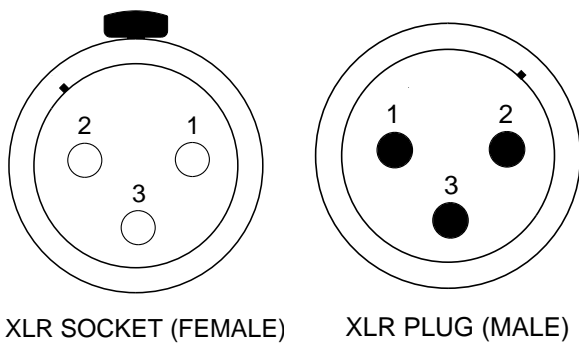

STANDARD XLR AUDIO PINOUTS:

- 1: Ground/ Earth
- 2: INPHASE/ POSITIVE/ MIC +
- 3: MATE/ NEGATIVE/ MIC -

Standard Headphone Wiring

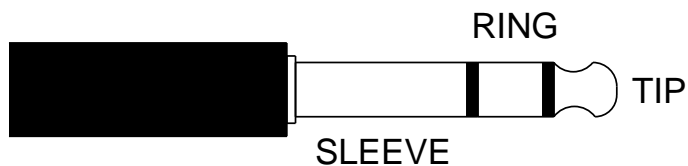

STANDARD HEADPHONE WIRING:

- TIP: A/ LEFT Ear
- RING: B/ RIGHT Ear
- SLEEVE: Common/ Earth

D9 Wiring & Loop Interconnecting To External Equipment

9 Pin D Plug Fitted to Device

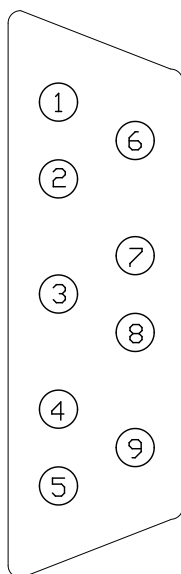

- 1) Loop Out 1 DIM LS
- 6) Loop Out 1 DIM LS
- 2) Loop Out 2 CUT LS
- 7) Loop Out 2 CUT LS
- 3) Input DIM LS
- 8) Input CUT LS
- 4) Input CUT INTERNAL LS (see note)
- 9) Spare Input
- 5) Ground

LOOP OUTPUT NOTE:

Internal device: Solid State Relay
Maximum current: 0.1A
Maximum voltage: 200 Volts

LOOP INPUT NOTE:

To operate connect circuit to ground
Maximum current: 3mA
High voltage level: +3.3 Volts

CUT INTERNAL LS INPUT

Making this loop does not illuminate the LED in the front panel CUT LS switch.