

Overview

The HDMI/RS232 Extender Kit (500454) allows HDMI equipment to be connected up to 131ft (40m) at 4K/30 (4:4:4) or 4K/60 (4:2:0) resolutions, or 230 ft (70 m) at resolutions up to 1080p via one (1) Cat 5e/6 unshielded twisted pair cable in a point-to-point configuration. The unit supports RS232 and bidirectional IR for end devices remote control. This kit comes with one (1) transmitter, one (1) receiver, one (1) IR Emitter, and one (1) IR sensor.

Applications

Digital signage, commercial AV systems, classroom projector systems, boardroom systems, collaborative PC systems, medical information systems.



Key Features

- Supports 1080p deep color and full 3D to distances of up to 230 ft (70m) over single Cat5e/6
- Supports 4K @ 24/25/30Hz (4:4:4) and 4K/60 (4:2:0) to distances of up to 131 ft (40m) over single Cat5e/6
- Supports RS232
- Supports Bi-directional IR pass through
- Supports all digital audio modes
- Includes IR emitter and IR sensor (carrier-wave)
- Compatible with 500454-PoE

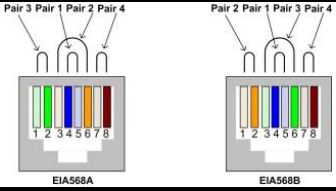
Specification Chart	
Environment	HDMI 1.4a (3D)
Devices	DVDs, Blu-ray players, projectors, monitors, TVs, PCs, laptops, servers supporting HDMI.
Transmission	Transparent to the user
Bandwidth	340MHz
Signals	HDMI 1.4a protocol
Connectors	One (1) HDMI receptacle. One (1) RJ45S for Cat5e/6 unshielded or shielded twisted pair. One (1) DB9 for RS232.
<i>Cables not included</i>	Two (2) 3.5mm sockets for IR Sensor & Emitter (carrier-wave). One (1) 2.1mm locking power connector.
Max. Distance*	4K/30 (4:4:4): Cat 5e/6: 131ft (40m) 4K/60 (4:2:0): Cat 5e/6: 131ft (40m) 1080p: Cat 5e/6: 230ft (70m) 1080p Deep Color: Cat 5e/6: 230ft (70m)
<i>*Based on a maximum length of 6.6 ft (2m) of HDMI cable per end</i>	<i>When installed in an electrically noisy environment, STP cable must be used. Also, cross-connection reduces the effective distance depending on the grade of twisted cable used.</i>
RJ45 Pin Configuration	RJ45 Pin 1 (R) Pin 2 (T) Pin 3 (R) Pin 6 (T) Pin 4 (R) Pin 5 (T) Pin 7 (R) Pin 8 (T)
<i>Reverse Polarity Sensitive Use EIA/TIA 568 A or B, straight-through wiring.</i>	
Cable	One (1) Category 5e or better twisted pair cables required.
Power Supply	Two (2) 110-240V/5VDC power supplies with interchangeable blades.
Power Consumption	Transmitter: 1.6 Watt Receiver: 3.2 Watt
Temperature	Operating: 0° to 40° C. Storage:-20° to 85° C. Humidity: up to 95% non-condensing.
Enclosure	Metal
Dimensions	4.40" x 3.00" x 1.00" (11.2 x 7.6 x 2.5 cm)
Weight	1.4 lbs (.6 kg)
Compliance	Regulatory: FCC, CE, RoHS, UL, cUL, TUV
Warranty	2 years
Order Information	500454 HDMI/RS232 Extender Kit, HDBT, UHD-4K (UPC: 627699004548) 500454-RX, HDMI/RS232 Receiver, HDBT, UHD-4K (UPC: 627699804544)
Accessories	500905 Rackmount Transceiver Chassis 3 Port 500920 Rackmount Transceiver Chassis 16 Port

Typical Application Schematic

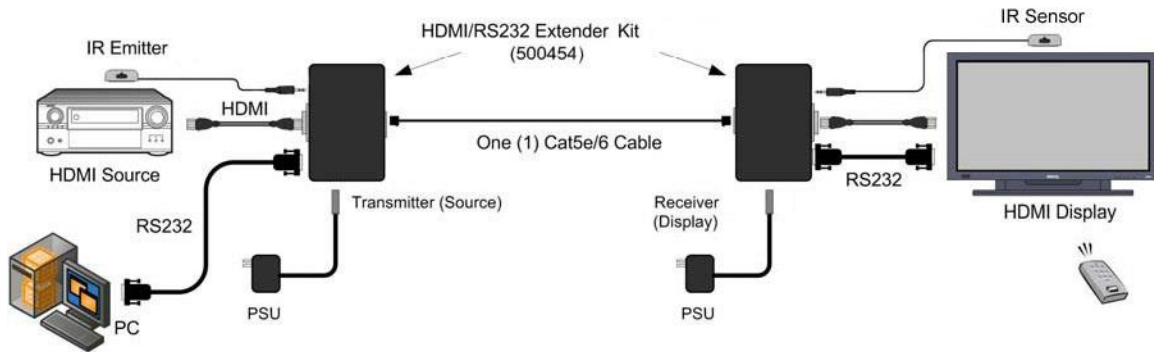

(61) 3051-5800

