

What Ships in the Box

- The RC-3 hardware device.
- This Quick Start Guide.

Getting Help

All Symetrix software, the Windows applications that control all Symetrix hardware, include a help module which acts as a complete User's Guide for both hardware (including the Modular ARCs) and software.

If you have questions beyond the scope of the help module, contact our Customer Support Group in the following ways:

Tel: +1.425.778.7728
7:00 am to 5:00 pm
Monday through Friday,
Pacific Time

Web: <http://www.symetrix.co>
Email: support@symetrix.co
Chat: <http://symetrix.casengo.com/vip/>

Note: This equipment has been tested and found to comply with the limits for a Class B digital device, pursuant to part 15 of the FCC Rules. These limits are designed to provide reasonable protection against harmful interference in a residential installation. This equipment generates, uses and can radiate radio frequency energy and, if not installed and used in accordance with the instructions, may cause harmful interference to radio communications. However, there is no guarantee that interference will not occur in a particular installation. If this equipment does cause harmful interference to radio or television reception, which can be determined by turning the equipment off and on, the user is encouraged to try to correct the interference by one or more of the following measures:

- Reorient or relocate the receiving antenna.
 - Increase the separation between the equipment and receiver.
 - Connect the equipment into an outlet on a circuit different from that to which the receiver is connected.
 - Consult the dealer or an experienced radio/TV technician for help.
- Modifications not expressly approved by the manufacturer could void the user's authority to operate the equipment under FCC rules.
 Cet appareil numérique de la classe B respecte toutes les Exigences du Règlement sur le matériel brouilleur du Canada.

Important Safety Instructions

- 1 Read these instructions.
- 2 Keep these instructions.
- 3 Heed all warnings.
- 4 Follow all instructions.
- 5 Do not use this apparatus near water. This apparatus shall not be exposed to dripping or splashing and no objects filled with liquids, such as vases, shall be placed on the apparatus.
- 6 Clean only with dry cloth.
- 7 Do not block any ventilation openings. Install only in accordance with the manufacturer's instructions.
- 8 Do not install near any heat sources such as radiators, heat registers, stoves, or other apparatus (including amplifiers) that produce heat.
- 9 This apparatus shall be connected to a mains socket outlet with a protective earthing connection. Do not defeat the safety purpose of the polarized or grounding-type plug. A polarized plug has two blades with one wider than the other. A grounding type plug has two blades and a third grounding prong. The wide blade or the third prong are provided for your safety. If the provided plug does not fit into your outlet, consult an electrician for replacement of the obsolete outlet.
- 10 Ensure proper ESD control and grounding when handling exposed I/O terminals.
- 11 Protect the power cord from being walked on or pinched particularly at plugs, convenience receptacles, and the point where they exit from the apparatus.
- 12 Only use attachments/accessories specified by the manufacturer.
- 13 Use only with the cart, stand, tripod, bracket, or table specified by the manufacturer, or sold with the apparatus. When a cart is used, use caution when moving the cart/apparatus combination to avoid injury from tip-over.
- 14 Unplug this apparatus during lightning storms or when unused for long periods of time.
- 15 Refer all servicing to qualified service personnel. Servicing is required when the apparatus has been damaged in any way, such as power-supply cord or plug cord is damaged, liquid has been spilled or objects have fallen into the apparatus, the apparatus has been exposed to rain or moisture, does not operate normally, or has been dropped.

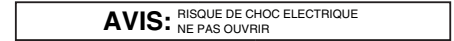
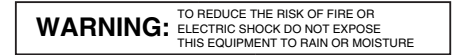

SEE OWNERS MANUAL. VOIR CAHIER D'INSTRUCTIONS.
 No user serviceable parts inside. Refer servicing to qualified service personnel.
 Il ne se trouve à l'intérieur aucune pièce pouvant être réparée l'utilisateur.
 S'adresser à un réparateur compétent.

- ◆ **The lightning flash** with arrowhead symbol within an equilateral triangle is intended to alert the user of the presence of uninsulated "dangerous voltage" within the product's enclosure that may be of sufficient magnitude to constitute a risk of electric shock to persons. The exclamation point within an equilateral triangle is intended to alert the user of the presence of important operating and maintenance (servicing) instructions in the literature accompanying the product (i.e. this Quick Start Guide).
- ◆ **CAUTION:** To prevent electric shock, do not use the polarized plug supplied with the device with any extension cord, receptacle, or other outlet unless the prongs can be fully inserted.
- ◆ **Power Source:** This Symetrix hardware uses a universal input supply that automatically adjusts to the applied voltage. Ensure that your AC mains voltage is somewhere between 100-240 VAC, 50-60 Hz. Use only the power cord and connector specified for the product and your operating locale. A protective ground connection, by way of the grounding conductor in the power cord, is essential for safe operation. The appliance inlet and coupler shall remain readily operable once the apparatus has been installed.
- ◆ **User Serviceable Parts:** There are no user serviceable parts inside this Symetrix product. In case of failure, customers inside the U.S. should refer all servicing to the Symetrix factory. Customers outside the U.S. should refer all servicing to an authorized Symetrix distributor. Distributor contact information is available online at: <http://www.symetrix.co>.

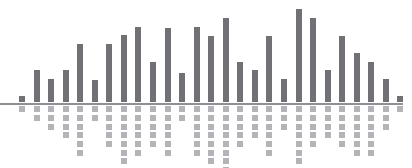

xControl Hook-up

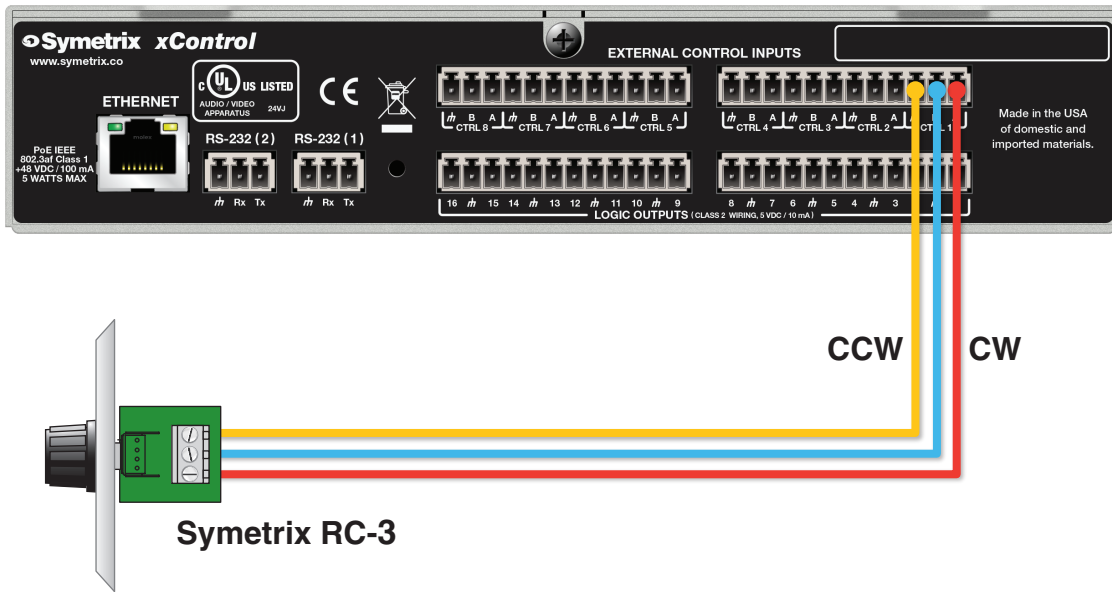

Radius 12x8 EX Hook-up

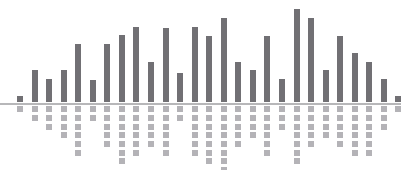
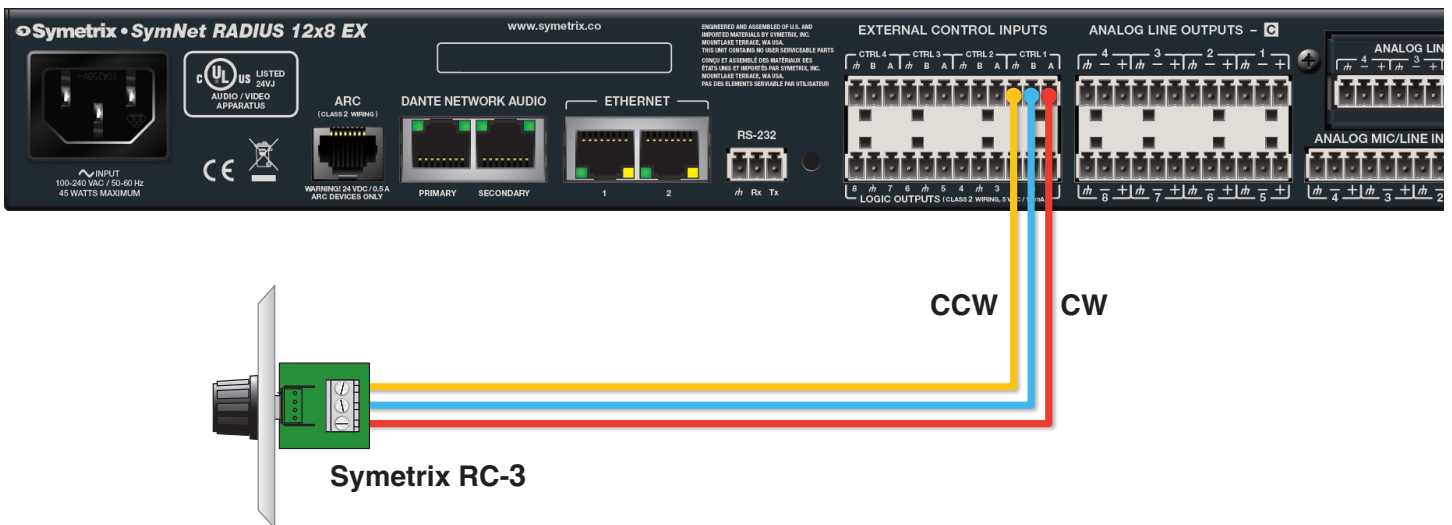

The Symetrix Limited Warranty

By using Symetrix products, the Buyer agrees to be bound by the terms of this Symetrix Limited Warranty. Buyers should not use Symetrix products until the terms of this warranty have been read.

What is Covered by this Warranty:

Symetrix, Inc. expressly warrants that the product will be free from defects in material and workmanship for three (3) years from the date the product is shipped from the Symetrix factory. Symetrix' obligations under this warranty will be limited to repairing or replacing, at Symetrix' option, the part or parts of the product which prove defective in material or workmanship within the warranty period provided that the Buyer gives Symetrix prompt notice of any defect or failure and satisfactory proof thereof. Symetrix may, at its option, require proof of the original date of purchase (copy of original authorized Symetrix Dealer's or Distributors invoice). Final determination of warranty coverage lies solely with Symetrix. This Symetrix product is designed and manufactured for use in professional audio systems and is not intended for other usage. With respect to products purchased by consumers for personal, family, or household use, **Symetrix expressly disclaims all implied warranties, including, but not limited to, warranties of merchantability and fitness for a particular purpose.** This limited warranty, with all terms, conditions and disclaimers set forth herein, shall extend to the original purchaser and anyone who --purchases the product within the specified warranty period from an authorized Symetrix Dealer or Distributor. This limited warranty gives the Buyer certain rights. The Buyer may have additional rights provided by applicable law.

What is not Covered by this Warranty:

This warranty does not apply to any non-Symetrix branded hardware products or any software even if packaged or sold with Symetrix Products. Symetrix does not authorize any third party, including any dealer or sales representative, to assume any liability or make any additional warranties or representation regarding this product information on behalf of Symetrix.

This warranty also does not apply to the following:

1. Damage caused by improper use, care, or maintenance or failure to follow the instructions contained in the Quick Start Guide or Help File.
2. Symetrix product that has been modified. Symetrix will not perform repairs on modified units.
3. Symetrix software. Some Symetrix products contain embedded software or apps and may also be accompanied by control software intended to be run on a personal computer.
4. Damage caused by accident, abuse, misuse, exposure to liquids, fire, earthquake, acts of God, or other external causes.
5. Damage caused by service (including upgrades and expansions) performed by any person not authorized by Symetrix.
6. Cosmetic damage, including but not limited to scratches and dents, unless failure has occurred due to a defect in materials or workmanship within the warranty period.
7. Conditions caused by normal wear and tear or otherwise due to the normal aging of Symetrix products.
8. Damage caused by use with another product.
9. Product on which any serial number has been removed, altered or defaced.
10. Product that isn't sold by an authorized Symetrix Dealer or Distributor.

Buyer Responsibilities:

Symetrix recommends the Buyer make backup copies of site files before having a unit serviced. During service it is possible that the site file will be erased. In such an event, Symetrix is not responsible for the loss or the time it takes to reprogram the site file.

Legal Disclaimers and Exclusion of other Warranties:

The foregoing warranties are in lieu of all other warranties, whether oral, written, express, implied or statutory. Symetrix, Inc. expressly disclaims any IMPLIED warranties, including fitness for a particular purpose or merchantability. Symetrix' warranty obligation and Buyer's remedies hereunder are SOLELY and exclusively as stated herein.

Limitation of Liability:

The total liability of Symetrix on any claim, whether in contract, tort (including negligence) or otherwise arising out of, connected with, or resulting from the manufacture, sale, delivery, resale, repair, replacement or use of any product will not exceed the retail price of the product or any part thereof which gives rise to the claim. In no event will Symetrix be liable for any incidental or consequential damages including but not limited to damage for loss of revenue, cost of capital, claims of Buyers for service interruptions or failure to supply, and costs and expenses incurred in connection with labor, overhead, transportation, installation or removal of products, substitute facilities or supply houses.

Servicing a Symetrix Product:

The remedies set forth herein shall be the Buyer's sole and exclusive remedies with respect to any defective product. No repair or replacement of any product or part thereof will extend the applicable warranty period for the entire product. The specific warranty for any repair will extend for a period of 90 days following the repair or the remainder of the warranty period for the product, whichever is longer.

Residents of the United States may contact the Symetrix Technical Support Department for a Return Authorization (RA) number and additional in-warranty or out-of-warranty repair information.

If a Symetrix product requires repair services outside of the United States please contact the local Symetrix dealer or distributor for instructions on how to obtain service.

Products may be returned by Buyer only after a Return Authorization number (RA) has been obtained from Symetrix. Buyer will prepay all freight charges to return the product to the Symetrix factory. Symetrix reserves the right to inspect any products which may be the subject of any warranty claim before repair or replacement is carried out. Products repaired under warranty will be returned freight prepaid via commercial carrier by Symetrix, to any location within the continental United States. Outside the continental United States, products will be returned freight collect.

