



5-Year Warranty



Hand-built in Webster, NY

ASHLY

rhox
áudio e vídeo pro

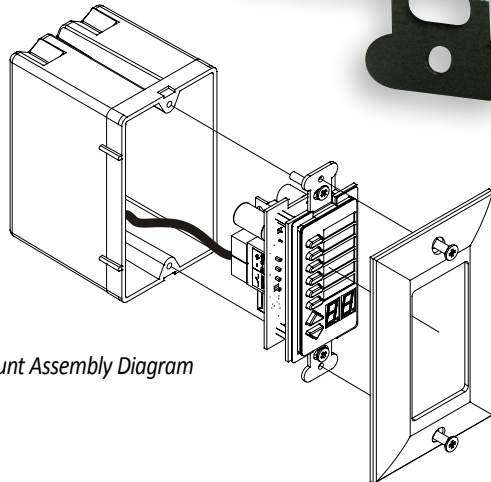
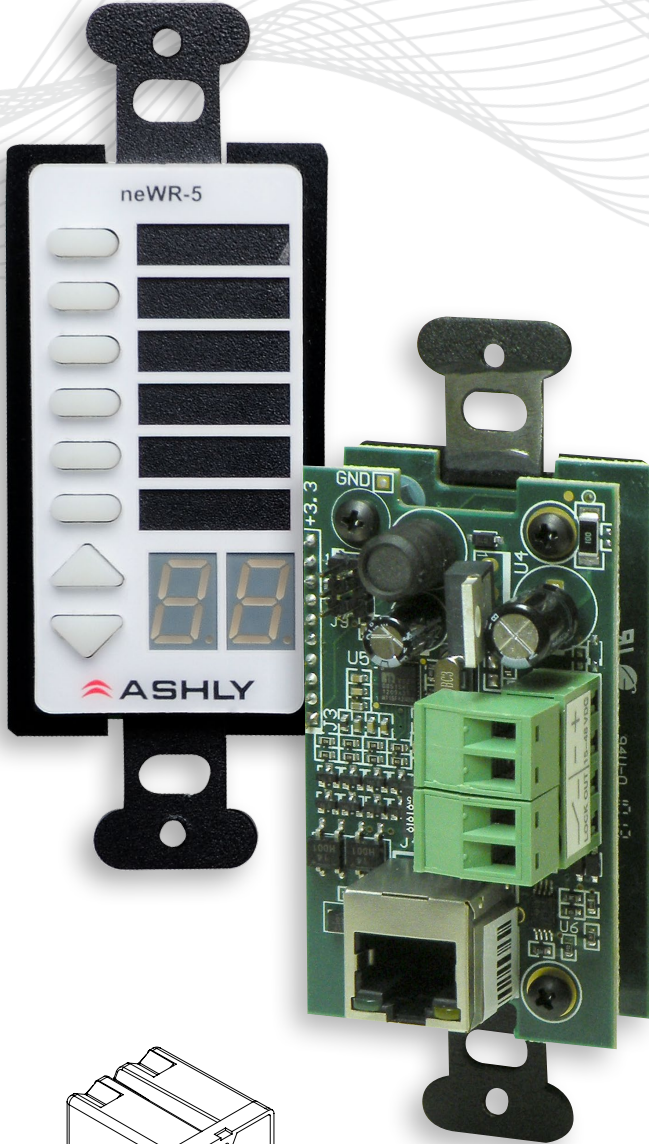

Wall Mount Assembly Diagram

neWR-5

PROGRAMMABLE MULTI-FUNCTION NETWORK DECORA WALL REMOTE

Control your system from any location with our Network Enabled remote controls. This device fits in standard wall boxes and uses a wired Ethernet network connection for hook-up.† The **neWR-5** is a programmable remote button controller for Ashly Network Enabled amps and processors. One neWR-5 targets only one NE amp or processor, but within that unit can adjust preset recall/scroll, channel mute, zone source selection, individual channel level, matrix point level, and logic output if available. All button programming is done across the network using Ashly Protea NE Software.

neWR-5 Features:

- Six programmable LED function buttons
- Two, Up/Down buttons w/ LED display adjust parameters
- Preset recall and preset scroll
- Input, output, zone, and matrix mix level control
- Zone source select
- Channel mute
- Logic high/low Output (ne24.24M w/ GPO option, ne4800/8800)
- Powered using IEEE 802.3af Power over Ethernet, or external supply**
- RJ-45 Ethernet connector, 100M maximum cable distance
- Hard-wired Lock-out connector for security key switch
- Window for user-defined labels

Compatible Ashly Products include:

- nXe*, nXp amplifiers
- Pema amplifiers
- NE multi-channel amplifiers*
- NE two-channel amplifiers*
- ne24.24M matrix processor
- NE8800/4800 network processors

† To prevent static discharge issues, neWR-5 frame should be earth grounded at point of installation

* Use on products without DSP is limited to preset recall/scroll, mute, and logic functions

** POE Injector, or external 15-48VDC power supply capable of at least 2 watts per neWR-5



neWR-5 ARCHITECT & ENGINEERING SPECS

The programmable remote control unit shall use Ethernet to control Ashly Network Enabled (NE) products. The unit shall have six programmable LED function buttons and two up/down buttons with adjacent numeric LED display for adjusting parameters. The unit shall be powered using IEEE 802.3af Class 1 Power Over Ethernet (PoE). The unit shall have a hard-wired lock-out connection for security key switch that disables all buttons. The unit shall be programmed using Ashly Protea NE Software, and offer control of preset recall/scroll, channel mute, zone source selection, individual channel level, matrix point level, and logic output if available on the targeted Ashly device. The unit shall have clear windows for insertion of user-defined function button labels. The unit shall mount in a standard US electrical wall box. No other unit shall be acceptable unless all specifications herein are verified through an independent agent.

The unit shall be an Ashly Audio **neWR-5**.

