

## HAL System Description

HAL is more than just another DSP drag-and-drop system. It has revolutionized system design and installation.

HAL is an expert in room combining, paging and distributed audio systems. This groundbreaking architecture is dimensions beyond any solution in any industry. HAL easily guides even novice users through what used to be complex tasks in just minutes. No intricate matrix mixing or presets are required for room combining and paging. No virtual wiring is required to distribute pages and background music to multiple, even hundreds of zones.

Seamlessly interface HAL to your application with web controls and/or a broad variety of peripheral devices including smart Digital Remotes, Remote Audio Devices (RADs), portable or rack automixers, audio I/O and logic expansion devices, wall sensors, ambient sensing mics, small remote amplifiers, and an advanced Paging Station.

In addition, the HAL Multiprocessor and Halogen™ software check the status, location, CAT 5 wiring integrity, and that audio is flowing in all peripheral devices, so you know your system is properly connected and ready to go.

Four HAL multiprocessors provide various audio I/O and control options for both large and small installations.

- HAL1x supports 16 in x 16 out audio, which may be increased up to 528 in x 528 out by adding up to 32 daisy-chained Expanders to a single HAL1x. Add a few to hundreds of more mic inputs with AM Automixers.
- HAL2 supports 18 in x 18 out audio, of which 2 x 2 are via AES3 on XLR connections.
- HAL3s supports 6 in x 10 out audio. The 2 “Mic/Line-Plus” Inputs accept balanced, or unbalanced left/right monoed.
- HAL4 supports 2 in x 2 out audio. The 2 “Mic/Line-Plus” Inputs accept balanced, or unbalanced left/right monoed.

See the “HAL Comparison” on page 2.

Since the same Halogen software code runs on both Windows® and within HAL hardware, third-party control developers can test all their code using only the Halogen Windows software. Use only software for complete system design and validation. Buy the hardware only when the install date arrives. Standard TCP/IP set and get ASCII text messages control levels, selectors, presets and toggle software actions.

Halogen software includes Ethernet control support for third-party control systems. AMX, Crestron and Stardraw Control Support Packages are installed with Halogen software, or available as separate downloads.

Halogen includes support for custom Web Controls using any device with a web browser such as a tablet, smartphone or laptop.

**Download Halogen and design a system now!**  
[rane.com/hal](http://rane.com/hal)

These Packages are installed with Halogen software, or available as separate downloads.

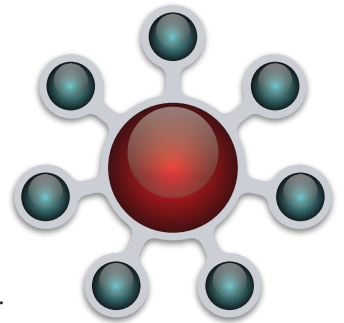

**HALOGEN**

**Now with Customizable Web Controls**

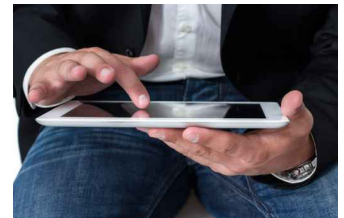

# HAL2

## Multiprocessor



### HAL Comparison

#### HAL1x Multiprocessor

- 16 in x 16 out - 8x8 analog & 8x8 digital (RAD ports).
- Up to 4 RADs (without EXP1x), up to 260 RADs (with 32 EXP1s).
- Up to 12 Digital Remotes (without EXPs), up to 268 (with EXPs).
- Four logic inputs, Two relay outputs (more with DR4 or DR5).

Analog Mic / Line Inputs 8	8 Analog Line Outputs
Digital RAD Port Inputs 8	8 Digital RAD Port Outputs
Digital Expansion into HAL1x 512	512 Digital Expansion from HAL1x
<b>Total in the HAL1x DSP Brain 528</b>	<b>528</b>
<b>Inputs</b>	<b>Outputs</b>

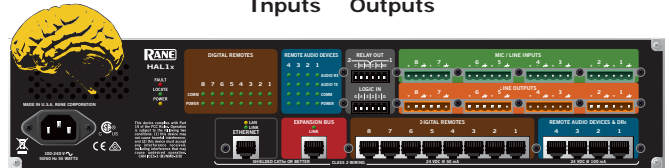
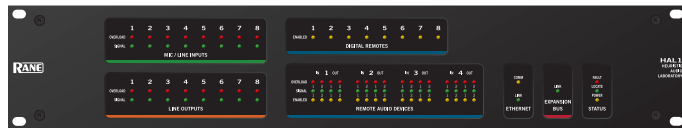

#### EXP1x Remote Audio Expander for HAL1x



Daisy-chain up to 32 EXPanders

- Adds 16 in x 16 out digital (8 more RAD ports) to HAL1x.
- Up to 8 Digital Remotes or RADs in any combination.
- Chain up to 32 EXP1x units to a HAL1x for 512 in x 512 out.

#### EXP2x Dante Expander for HAL1x



- Enables HAL1x to send / receive 32 channels to Dante devices.
- Supports 44.1, 48, 88.2 or 96 kHz Dante network sample rates.
- Chain up to 16 EXP2x units to a HAL1x for 512 in x 512 out.

#### EXP3x Zone Output Expander for HAL1x



- Adds 8 analog line outputs and 8 logic outputs to a HAL1x.
- Adds 6 Digital Remote ports & 2 RAD ports to a HAL1x.
- Chain up to 32 EXP3x units to a HAL1x for 256 outputs.

#### EXP5x Input Expander for HAL1x

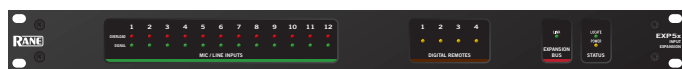

- Adds 12 analog mic / line/ line-plus\* inputs to a HAL1x.
- Adds 4 Digital Remote ports to a HAL1x.
- Chain up to 32 EXP5x units to a HAL1x for 384 analog outputs.

#### EXP7x AEC Expander for HAL1x



- Adds 8 channels of Acoustic Echo Cancelling DSP to a HAL1x.
- Chain up to 32 EXP7x units to a HAL1x for 256 AEC channels.

Dante is a trademark of Audinate Pty Ltd, Audinate is a registered trademark of Audinate Pty Ltd.

### HAL2 Multiprocessor

- 18 in x 18 out - 8x8 analog & 8x8 digital (RAD ports) & AES3 I/O.
- Up to 8 Digital Remotes.
- Four logic inputs (closure), Two relay outputs.
- Four IR Ports for IR2 Wall Sensors.

Analog Mic / Line Inputs 8	8 Analog Line Outputs
Digital RAD Port Inputs 8	8 Digital RAD Port Outputs
(AES3) Input Channels 2	2 (AES3) Output Channels
<b>Total in the HAL2 DSP Brain 18</b>	<b>18</b>
<b>Inputs</b>	<b>Outputs</b>

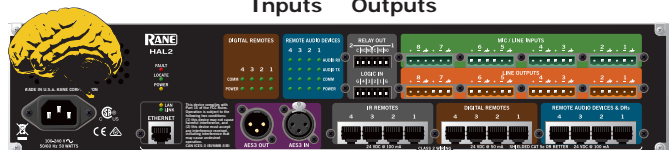

## HAL Comparison

### HAL3s Multiprocessor

- 6 line in x 10 line out - 2x6 analog & 4x4 digital (RAD port).
- 2 Mic/Line/Line-Plus Inputs.\*
- Up to four Digital Remotes.
- Four logic inputs (closure).



Analog Line-Plus Inputs 2	6 Analog Line Outputs
Digital RAD Port Inputs 4	4 Digital RAD Port Outputs
Total in the HAL3s DSP Brain 6	10
Inputs	Outputs

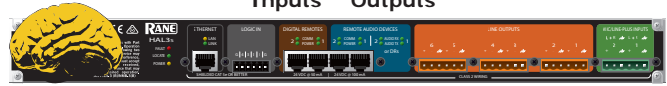

### HAL4 Multiprocessor

- \* 2 Mic/Line/Line-Plus Inputs can wire "mic level," "mic with phantom," "line level balanced," or "unbalanced L/R monoed."
- 2 balanced line outputs.
- One Digital Remote Port.



Analog Mic/Line-Plus Inputs 2	2 Analog Line Outputs
Total in the HAL4 DSP Brain 2	2
Inputs	Outputs



## RAD and DR Cable Lengths

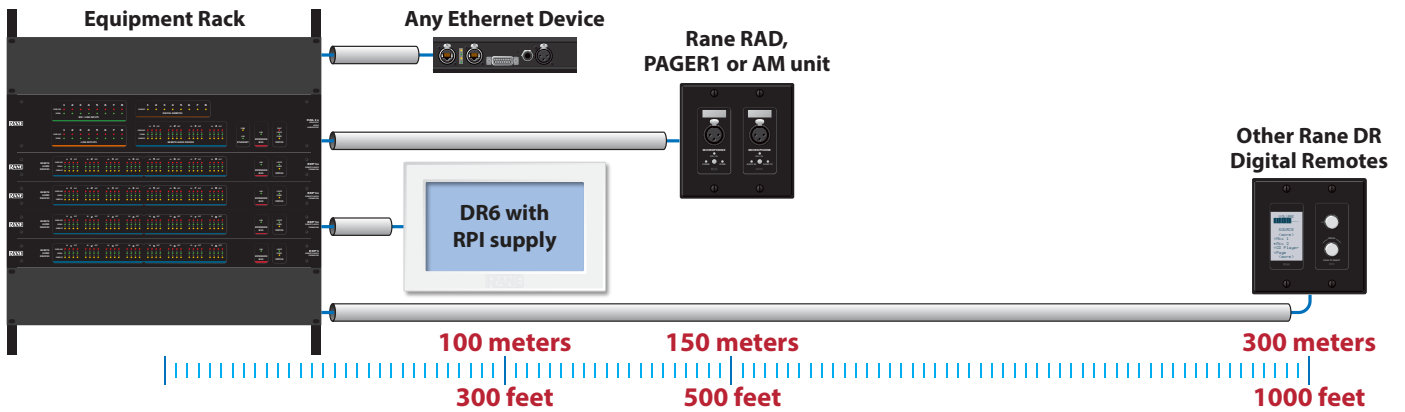

## Latency

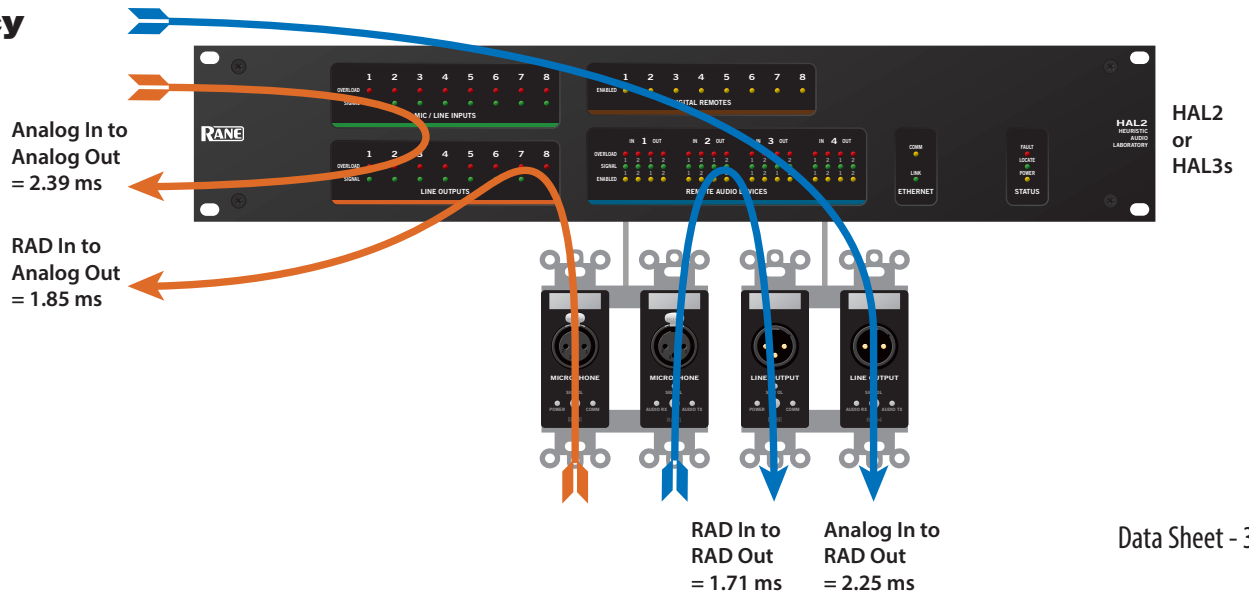

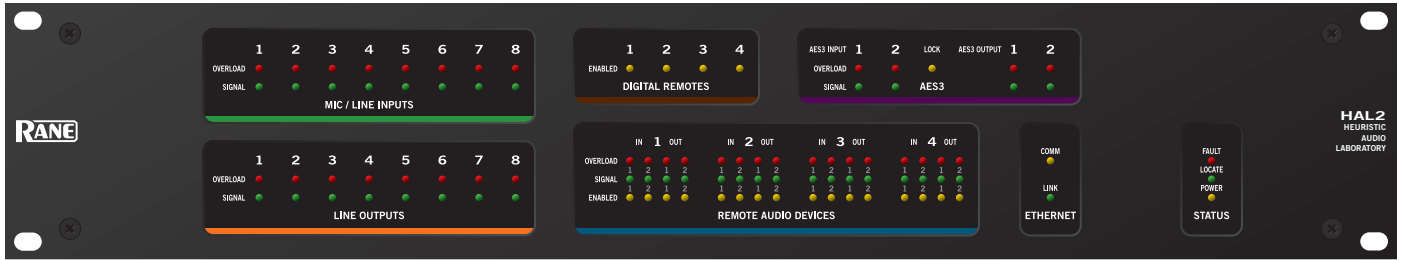

## HAL2 Specifications

Parameter	Specification	Limit	Conditions/Comments
<b>Analog I/O</b>	8 x 8		
...Connectors	Euroblock		4 x 6-pin, 5 mm pitch, Green = Inputs, Orange = outputs
...CODEC	24-bit, 48 kHz		
<b>Mic Inputs</b>	Active Balanced		
...Gain Settings	+10 to +60 dB		1 dB steps
...Input Impedance	2.6 kΩ	1%	1 kHz, each leg to ground
...Phantom Power	+48 VDC		10 mA max per input
...Equivalent Input Noise	-127 dBu	max	20-20k Hz, 150 Ω source, 60 dB gain, A-weighted
...THD+N	< 0.008 %	typ	20-20k Hz, +4 dBu, +10 dB gain, 20 kHz BW
...Maximum Input	3 dBV (1.4 Vrms)	typ	Input gain at +10 dB, 1 kHz, < 1% THD+N
...CMRR	55 dB	min	1 kHz
<b>Line Inputs</b>	Active Balanced		
...Gain Settings	Unity & +10 to +20 dB		1 dB steps from +10 to +20
...Input Impedance	5.1 kΩ	1%	1 kHz, each leg to ground
...THD+N	< 0.008 %	typ	20-20k Hz, +4 dBu, unity gain, 20 kHz BW
...Maximum Input	20.8 dBu	typ	Input gain at 0 dB, 1 kHz, <1% THD+N
...Frequency Response	20-20k Hz, +0, -.05 dB		+4 dBu, unity gain
...Dynamic Range	109 dB	max	re +20 dBu, 20 kHz BW, A weighted, Rs = 150 Ω
...Interchannel Isolation	104 dB	max	20-20k Hz, +20 dBu, unity gain, channel-to-channel
...CMRR	45 dB	min	1 kHz
<b>Outputs</b>	Active Balanced		
...Impedance	200 Ω	1%	Each leg
...Maximum Output	+20.9 / +16.4 dBu	typ	1 kHz, 100 kΩ / 600 Ω load
...Frequency Response	20-20k Hz, +0.1 / -0.3 dB		+4 dBu, unity gain, 100 kΩ load
...Dynamic Range	109 dB	max	re +20 dBu, 20 kHz BW, A-weighted, 100 kΩ load
...Interchannel Isolation	110 dB	typ	20-20k Hz, +20 dBu, channel-to-channel, 100 kΩ load
<b>Indicators</b>			
...Signal	-50 dBFS	typ	Green LED, peak-reading
...Overload	-0.5 dBFS	typ	Red LED, peak-reading
<b>Propagation Delays</b>			See the Latency graphic on page page 6.
...RAD In to RAD Out	1.71 ms	typ	Tested with RAD23
...RAD In to Analog Out	1.85 ms	typ	
...Analog In to RAD Out	2.25 ms	typ	
...Analog In to Analog Out	2.39 ms	typ	
...HAL2 AES3 In to AES3 Out	2.50 ms	typ	AES3 input accepts sample rates from 32 kHz to 192 kHz. These are converted to the 48 kHz within HAL.

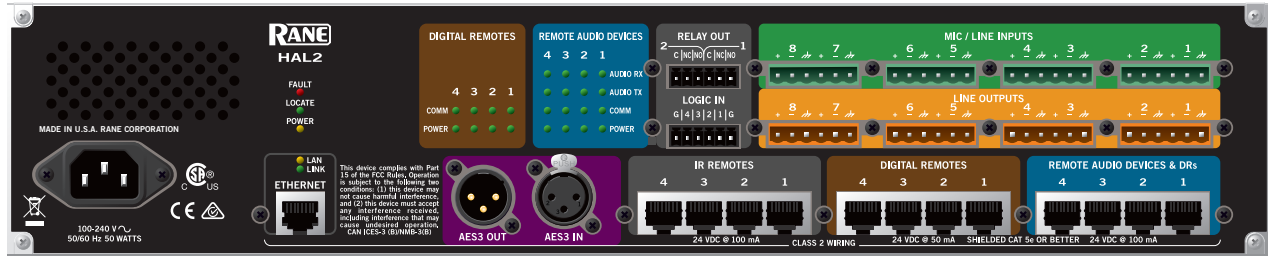

Parameter	Specification	Limit	Conditions/Comments
<b>DSP</b>			
...HAL2 Processing Power	4800 MIPS	max	2 DSPs @ 300 MHz each with up to 8 instructions / cycle
...Word Length	32 / 64-bit Floating Point		
...HAL2 Delay Memory	40 seconds	max	
<b>Computer Interface:</b> Type	Ethernet 1000 base-T		Zeroconf service discovery protocol for easy set up
...Cable	Shielded CAT 5e or better		RJ-45 connector
...Length	100 meters / 300 feet	max	Standard Ethernet cable length limit
<b>RAD Ports</b>	4		RJ-45 connectors
...Audio Channels	8 in x 8 out		Each port 2 in x 2 out, plus control channel, 24-bit, 48 kHz
...Power	24 VDC @ 100 mA	max	Each port
...Length	150 meters / 500 feet	max	Shielded CAT 5e cable or better
<b>HAL2 DR Ports</b>	4		RJ-45 connectors
...Power	24 VDC @ 50 mA	max	Each port
...Length	300 meters / 1000 feet	max	Shielded CAT 5e cable or better
<b>HAL2 IR Remote Ports</b>	4		RJ-45 connectors
...Type	Compatible with IR2 remote		Protected to +24 V, reverse polarity protected
...Power	24 VDC @ 100 mA	max	Normal state
...Length	300 meters / 1000 feet	max	Shielded CAT 5e cable or better
<b>Relay Outputs</b>	2		
...Connector	Mini Euroblock		6-pin, 3.81 mm pitch, Black
...Type	COM, NC & NO		
...Limit	2 A, 48 V	max	60 W max switching power
<b>Logic Inputs</b>	4		
...Connector	Mini Euroblock		6-pin, 3.81 mm pitch, Black
...Type	Internal passive pull-up		Protected to +24 V
...Vin High	> 2.2 V	min	Normal state
...Vin Low	< 1.0 V	max	External circuit sinks > 22 μA to assert
<b>Wiring</b>	Class 2		All rear panel terminals
<b>Power Requirement</b>	100 to 240 VAC		50/60 Hz, 50W max
<b>Ambient Room Temp.</b>	40 °C	max	Maximum external loading
<b>Unit: Conformity</b>	CE, FCC, cCSAus		
<b>Unit: Size</b>	2U, 3.5"H x 19"W x 8.25"D		(8.9 cm x 48.3 cm x 20.9 cm)
...Weight	7 lb		(3.2 kg)
<b>Shipping: Size</b>	6.5" x 20.3" x 13.75"		(11.5 cm x 52 cm x 35 cm)
...Weight	10 lb		(4.5 kg)

# HAL2

## Multiprocessor



### RADs

The entire family of RAD models interface with HAL, for digital conversion at the wall. Each converts analog audio to and/or from 24-bit, 48 kHz digital audio. Shielded CAT 5e (or better) cable and termination transport four digital audio channels – two channels each direction – as well as power, ground and a communications channel, with status indicators at each RAD, HAL or EXP unit, and in Halogen software. HAL auto-checks the CAT 5 crimp and verifies audio. All RADs (and DRs) are both “location-aware” and hot-swappable with 150 meter (500 feet) homerun connections (66% farther than Ethernet). Light sensors dim the RAD indicators in dark rooms. Except for the RAD16, AM1, AM2, and PAGER1, all RADs mount in standard US electrical boxes. Except for the RAD16, RAD17, RAD24, AM1, AM2, and PAGER1, all other RADs are available in white, ivory, or black, with a matched Decora® plate cover included.

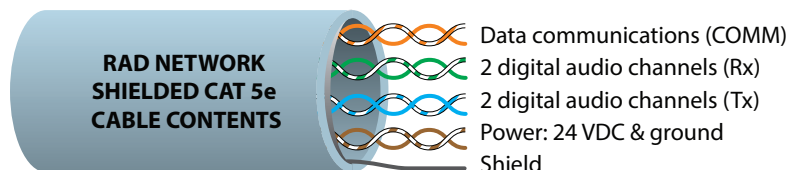

- RAD1 Dual XLR Mic Inputs
- RAD2 XLR Mic Input / Mini & RCA Mono'ed Line Input
- RAD3 Dual XLR Line Inputs
- RAD4 Dual XLR Line Outputs
- RAD5 AES3 Input / AES3 Output
- RAD6 Mini & RCA Stereo Line Input / Stereo Line Output
- RAD7 XLR Mic Input / XLR Line Input
- RAD8 XLR Mic Input / Mini & RCA Stereo Line Output
- RAD9 XLR Mic Input / XLR Line Output
- RAD11 XLR Mic In / Mini & RCA Mono'ed Line In / Mini & RCA Stereo Line Out
- RAD12 Dual XLR Mic Inputs / Dual XLR Line Outputs
- RAD14 XLR Mic In / Mini & RCA Mono'ed Line In / Dual XLR Line Out
- RAD15 Dual XLR Line Inputs / Dual XLR Line Outputs
- RAD16 Dual Mic-Line Input / Dual Line Output Euroblocks in a Box
- RAD17 Omnidirectional Boundary Layer Mic
- RAD18 XLR Mic Input / 1/4" Balanced Line Input
- RAD23 XLR Line Input / XLR Line Output
- RAD24 One-Watt, Plenum-Rated Amplifier
- RAD27 USB Audio Sound Card
- RADX RAD Port Extension (CAT 5 wall jack for portable RADs)
- AM1 Four-Channel Gain-Sharing Automixer with added Line Inputs
- AM2 Eight-Channel Gain-Sharing Cascadable Automixer
- PAGER1 Mic Preamp with Push-to-Talk and Page Zone Selection

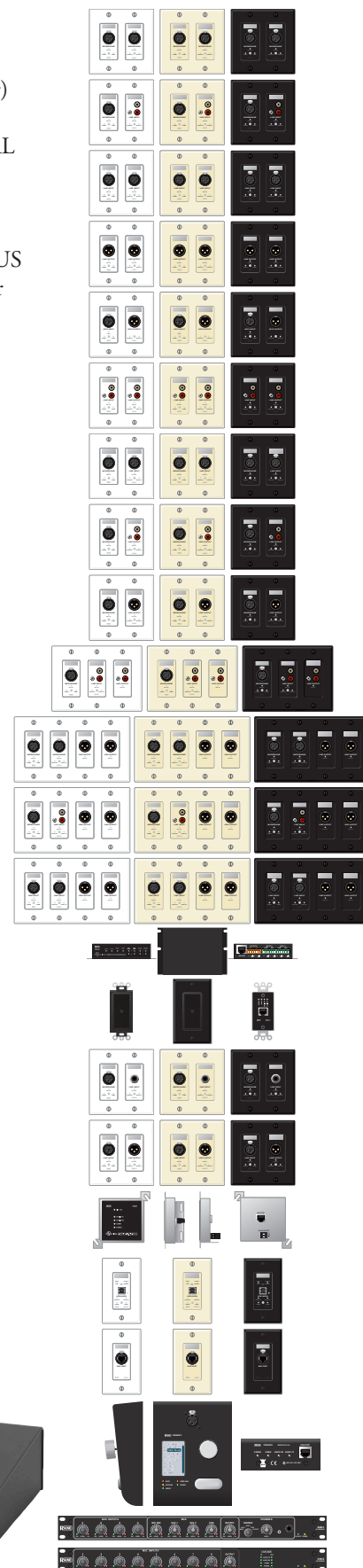

### PAGER1

#### Paging Station

This RAD has a mic preamp, paging zone(s) [Scenario] selector and an integrated push-to-talk switch. It sits on or can fasten to a tabletop, and accepts any gooseneck microphone (not included).



## Digital Remotes

Three Digital Remotes simplify end user control and eliminate installer brain fatigue. Use Digital Remotes for volume control, preset recall, source selection, or resetting or toggling system states. All offer customizable backlit LCD screens for intuitive end user labeling. Home run shielded CAT 5e (or better) connections to a HAL or EXP eliminate addressing, external power, and the need to test the cables.

The DR1 supports Level Control.

The DR2 offers Single Selector or List of Toggles/Commands behavior.

The DR3 has three behaviors: Single Level & List of Toggles/Commands, List of Levels for either multizone volume control and/or input source mixing, and Single Level plus Selector.

### DR1 Digital Volume Remote



Level Control

### DR2 Digital Selection Remote

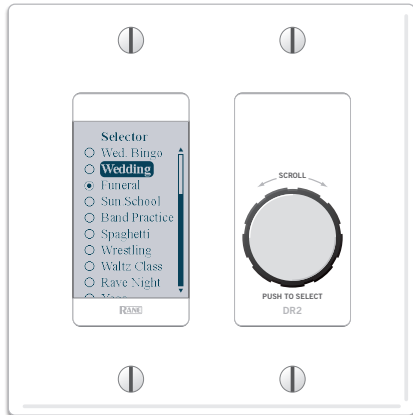

Single Selector

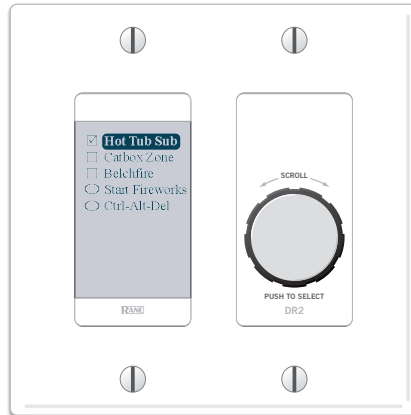

List of Toggles / Commands

### DR3 Digital Volume and Selection Remote

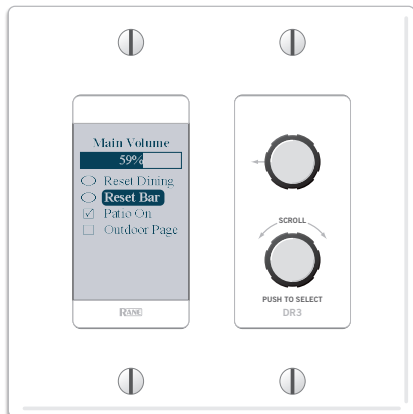

Single Level & List of Toggles / Commands

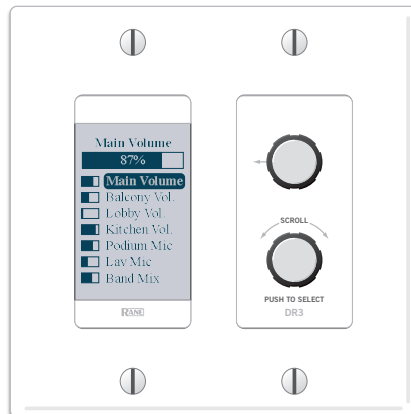

List of Levels

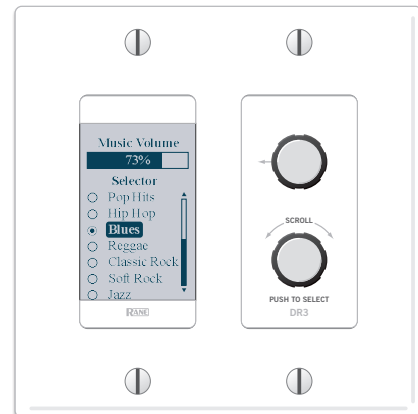

Single Level & Selector

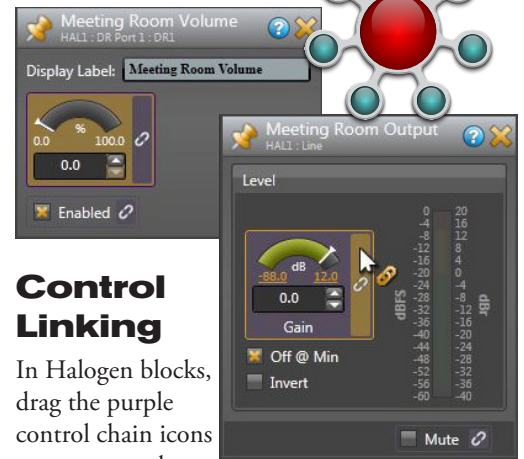
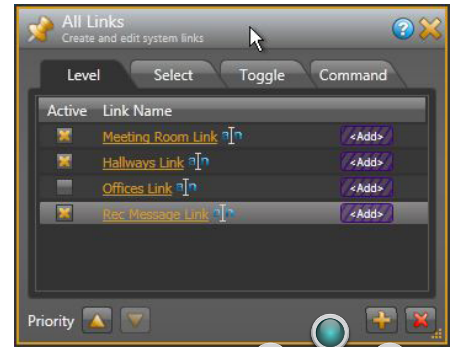

## Control Linking

In Halogen blocks, drag the purple control chain icons atop one another to

create links between Levels, Toggles, Selectors, Commands, Digital Remotes, Web Controls and/or 3rd-party controls. The above screen shows linking a DR1 volume onto the Meeting Room Output Level control. Four Control Link types and behaviors are supported: Level, Select, Toggle or Command. Activation and Priorities work together for incredible flexibility. Link simple analog remote level controls, contact closures and IR remote wall sensors by adding a DR4 Logic I/O Expander.

**DR4 Logic I/O Expander**

The DR4 Digital Remote adds additional logic input and output ports to any HAL, enabling simple analog level and logic I/O controls plus IR2 remotes for wall sensing. The DR4 offers eight logic ins and outs, six IR ports and eight analog input ports for

pot-on-a-wall level control. Multiple DR4's can connect to Digital Remote Ports on any HAL, up to 300 meters (1000 feet) away. See the Logic Inputs, Control Inputs and Logic Outputs on the next page.

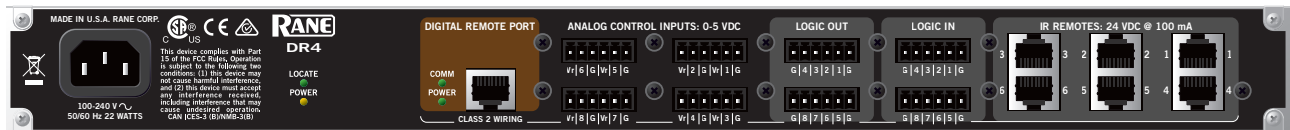

**DR5 Switch Controller Remote**

The DR5 Digital Remote offers additional logic input and output ports, enabling the use of simple analog switch controls in any HAL system. Lighted switch panels for room combine applications are easily integrated into a HAL system using the eight switch inputs and eight LEDs outputs on the DR5. Unlike the HAL and DR4 Logic I/O, the DR5 Logic Out is intended to drive the LED indicator on a room combine panel, and is a writable parameter. The DR5 is designed to fit in a standard US dual-gang electrical box or mount directly near a room combine panel.

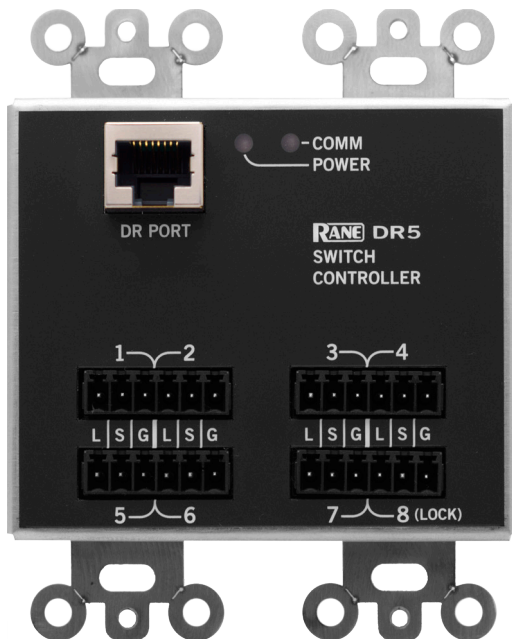
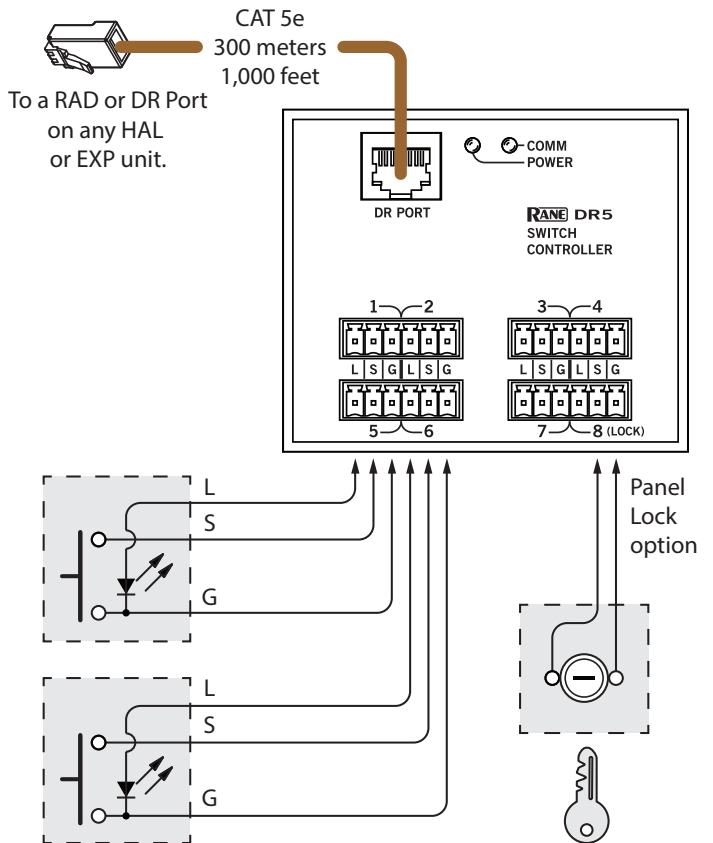

## HAL2 Logic Inputs

These inputs are found on the HAL2. More can be added with the DR4 or DR5, connectable to any DR port. You can configure each of the Logic Input ports in one of three ways: toggle, command, or selector.

The **Toggle** configuration allows a Toggle command with an on/off switch. You can configure each port type to be either *Momentary* or *Latching*.

The **Command** configuration allows triggering a Command control from an on/off switch, which can link to one or more Command controls such as a Command preset or a linkable button in a processing block property dialog.

The **Selector** configuration uses either a multi-position switch or a binary switch. You can connect a physical device to any or all of the Logic In ports and configure the ports in Halogen so they make the desired selection according to the state of the physical device. Wiring details are in the Halogen Software Help. The Selector configuration is not supported by the DR5.

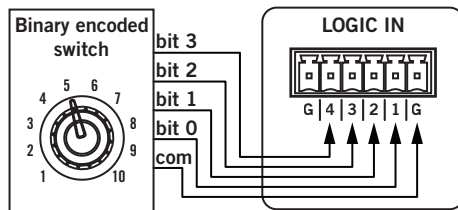
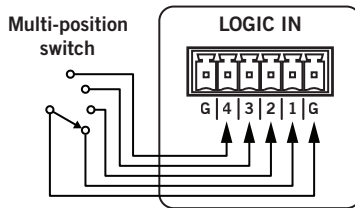
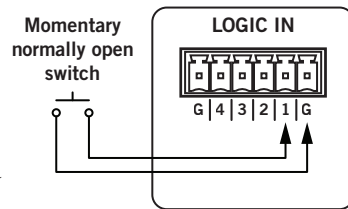

## DR4 Logic Outputs

These outputs are found on a DR4 that can connect to any HAL. You can configure each of the 8 output ports in one of 2 ways:

- **Toggle:** When a toggle control in the Halogen Control palette is unchecked, HAL sets the corresponding DR4 Logic Out port to logic high (5 V), and when the toggle is checked, it sets the port to logic low (0 V).
- **Selector:** When a selector control in the Halogen Control palette is set to the first selection, HAL sets the corresponding DR4 Logic Out port to logic high (5 V). Conversely, when the selector control is in the second position, HAL sets the port to logic low (0 V).

## HAL2 Relay Outputs

These reed relay ports are found on the HAL2 to signal other devices. A common implementation is to link a relay port to a Toggle control so an end user can change its value. Halogen software contains a checkbox for each relay port. Its value can be included in a preset or link to another control, making it possible to use a preset or control to turn the relay port on or off.

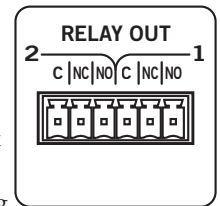

## DR4 Analog Control Inputs

These inputs are found on the DR4 that can connect to any HAL. Each port allows an analog voltage source to control the value of a Level control in the Halogen Control palette. The input range for the port is from 0 V to 5 V, where 0 V corresponds to 0% on the associated Level control and 5 V corresponds to 100%.

Connect a physical linear-taper potentiometer, like the Rane VR2 Volume Remote. The Vc wiper provides the control voltage to the DR4. As you adjust the pot the voltage changes, which in turn changes any linked Level control in Halogen.

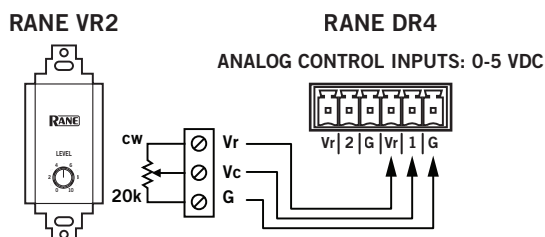

## AMX, Crestron and Stardraw Support Packages

These Control System Guides include an introduction to external control systems with HAL. Each appendix includes reference information on the HAL external control message protocol and how to use a telnet client to monitor and troubleshoot control system operation. Each package has an example HAL1x configuration and how to set up a controller for each touch panel to communicate with a Halogen/HAL Control Server.

The Support Packages are installed with the Halogen software and can be accessed from the Windows Start Menu under Rane Corporation > Halogen > Guides > AMX, Crestron or Stardraw.

**NEW! DR6 Touchscreen Remote**

The new DR6 is a fully customizable touchscreen remote for the HAL family. It supports multiple pages or tabs and any set of levels, toggles, selectors and/or commands. Drag, drop and resize controls any way that's desired. Use custom background images and logos in full-color on the 7-inch LCD display.

Screw the included wall-mount bracket over U.S. or international electrical boxes, or flush mount the 3/4" thick DR6 with a 2-inch hole in the wall to accommodate the cable. The optional DS1 desk stand accessory (shown) allows the DR6 to mount on a horizontal surface. The optional RB1 rack bracket installs the DR6 in a 19" equipment rack.

The included midspan power injector connects CAT5e (or better) cables between any HAL and the DR6 to deliver communications and the extra power needed for the display.

Optional, on-screen User Access logins secure management pages from public or staff use, and a programmable ambient light sensor automatically dims the backlight.

The Control Page Designer in Halogen 5.0 allows you to create one set of pages and use them in a web control design, DR6 display or both.

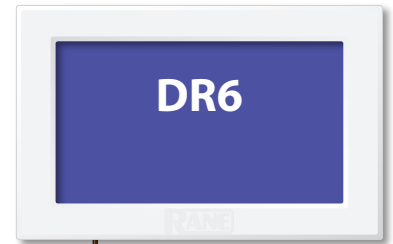
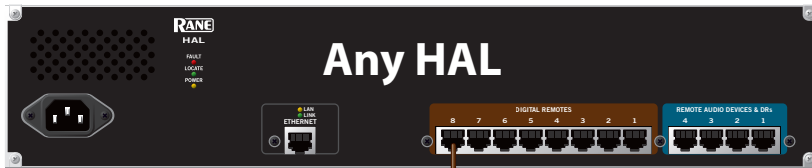
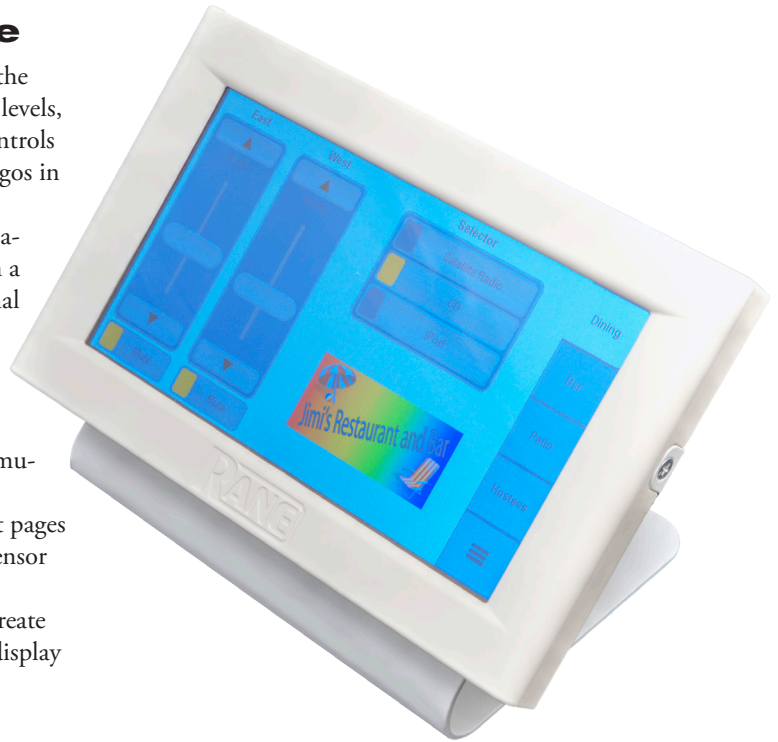

The RPI can go anywhere in between.

**DS1 Desk Stand Accessory**

- All steel, painted white.
- Rubber bottom protects the desktop.
- Kensington security hole.
- Holes in the bottom to fasten to a desktop.
- Larger hole in bottom to thread CAT 5 cable through the desktop.

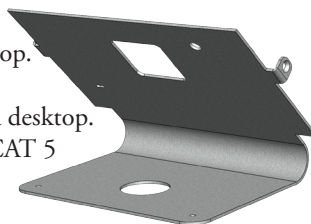

**RB1 Rack Bracket Accessory**

- All steel, painted black, 3U rack height.

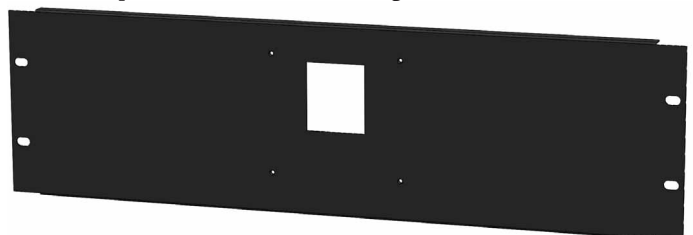

## Halogen Web Controls

Control the Levels, Selectors, Toggles and Commands in any HAL System from any device with a web browser. Halogen 4.0's Web Controls feature allows creation of custom HTML GUI control screens. Define the quantity of control pages, and the layout, labeling and size of each control, and completely test them using your default web browser from within Halogen.

Access any control page from any browser-enabled device on the network with a HAL device. Just open a browser and type in the customizable IP/webpage address for the HTML page – and bookmark it for easy access. Type in an optional User Access code, and voilà, the trick, she is done! Control your HAL system wirelessly from one or more tablets, smart phones, laptops or desktop computers. The HAL web server is multi-client, allowing control across many devices and many rooms. You can link Rane's wired DR remote controls (DR1, DR2 & DR3) and wireless devices and they'll automatically track each other.

Customers from almost every audio application are asking for "iPad control" and Halogen's Web Controls is the solution. It is not Apple®-centric — no iTunes® store or app installs required. We'll save a lot of space and ink on this page by not listing all the possible devices that support web browsers and wireless Ethernet. Besides, the list will change before the ink dries.

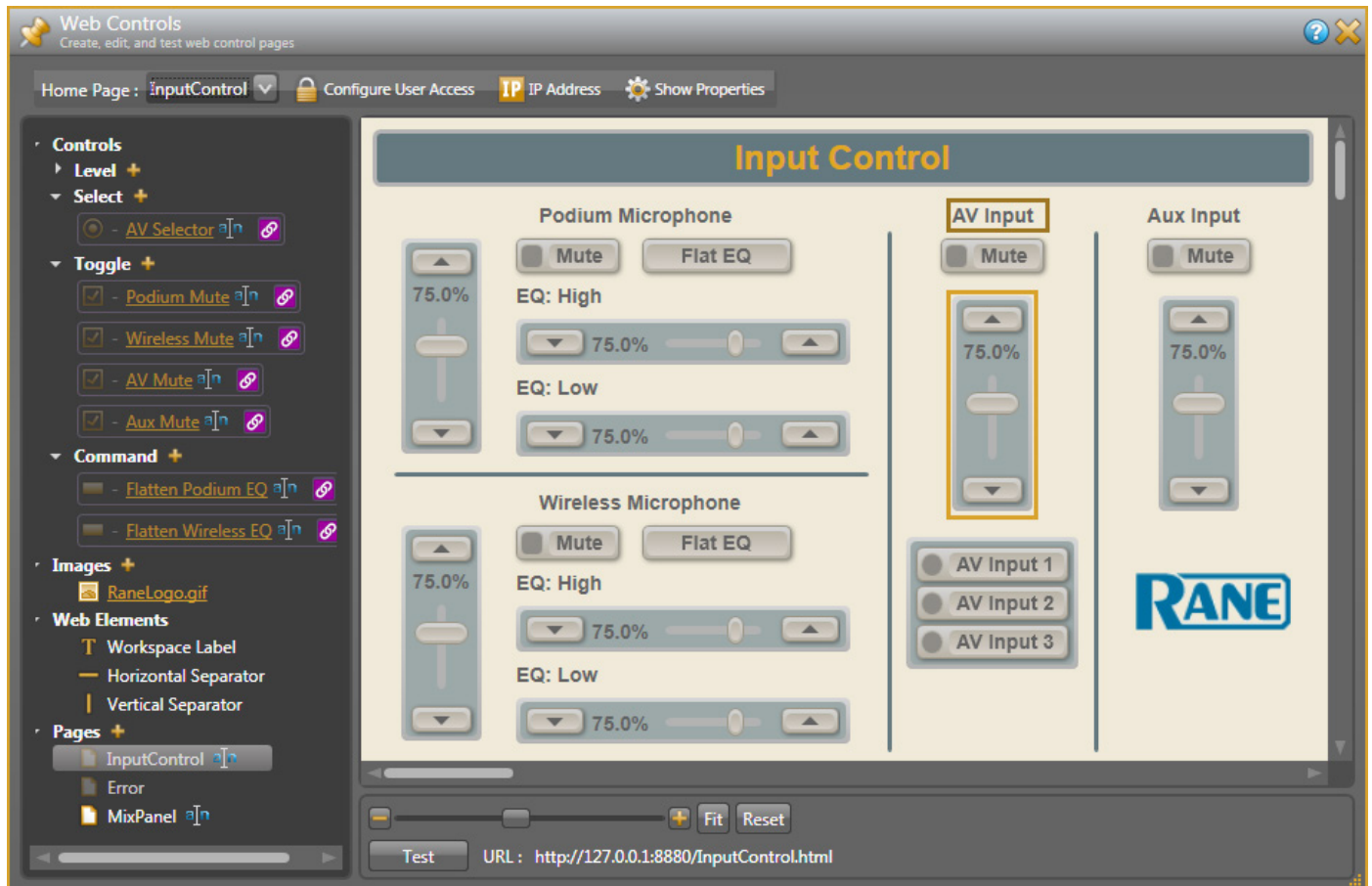
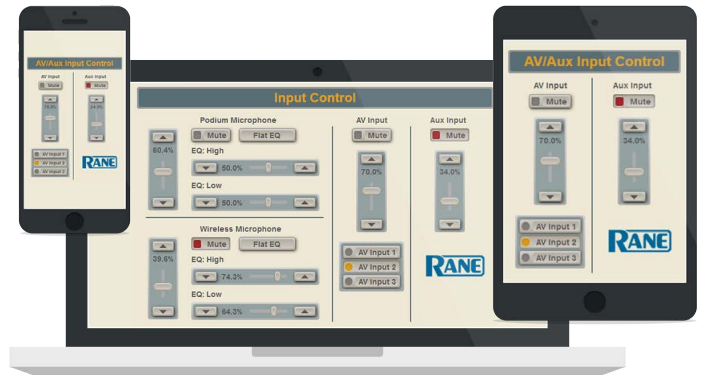
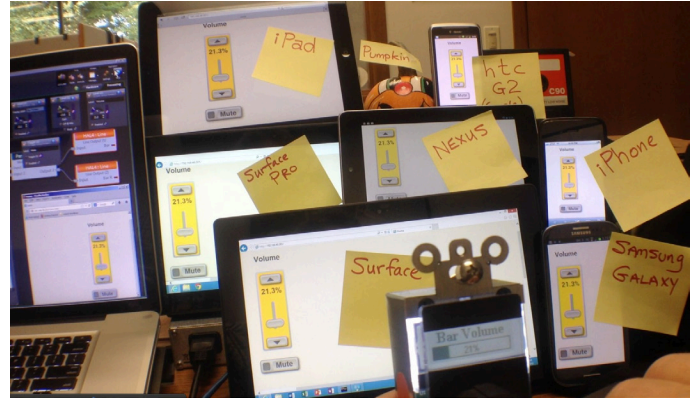

## IR2 Infrared Wall Sensors

The Rane IR2R and IR2S are collectively known as an IR2, working in pairs to provide an automatic way to sense the position of a movable wall or door. The IR2S sends infrared, the IR2R receives it. Mounting brackets and screws are included.

A single CAT 5e cable for each door connects the IR2 to a dedicated IR Remotes port on the rear of a HAL2 or a DR4.

When mounted on opposite sides of the wall, green indicators on the IR2R and IR2S are always lit. Only when the door is open and the IR2R is receiving infrared from the sender does the IR2R's amber indicator light. Depending on the IR2 mounting height and your eyeglass prescription, these indicators can usually be viewed from the floor.

For an IR2 remote to control audio, the IR2 requires a connection to a HAL2, or to a DR4 connected to any HAL loaded with a suitable configuration. When doors or movable partitions are opened or closed the IR2 automatically detects this, and the audio system reconfigures itself appropriately and automatically. The IR2 will operate up to 1.5 meters (5 feet) apart. See the IR2 Specifications on page 56.

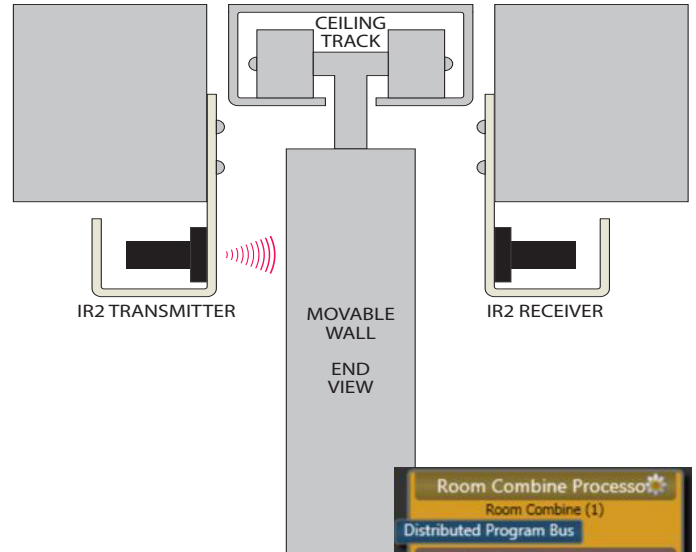
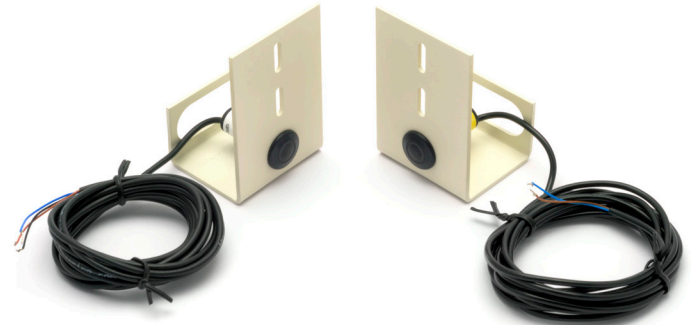

## Room Combining with the IR2

Both Room Combine Processors (regular and conferencing) support custom wall layouts and auto-activation of independent room processors for each possible physical room as walls open and close. Control linking between Rane IR2s, Digital Remotes, Web Controls, or 3rd-party controllers to wall open/close toggles and room processing and volumes is exquisitely intuitive, and these combine and separate automatically as wall states change. No presets required. Use Rane AM2 Automixers to gain-share auto-mixed mics in combined rooms and separate the mix automatically as walls close. Gain-share with both in-room mics and wireless mics when cascaded into a HAL's room combine processor. This means AM2 mixers can be hot-swapped between locations for quick setup at head table discussions.

## Example HAL2 with IR2 Wall Sensors

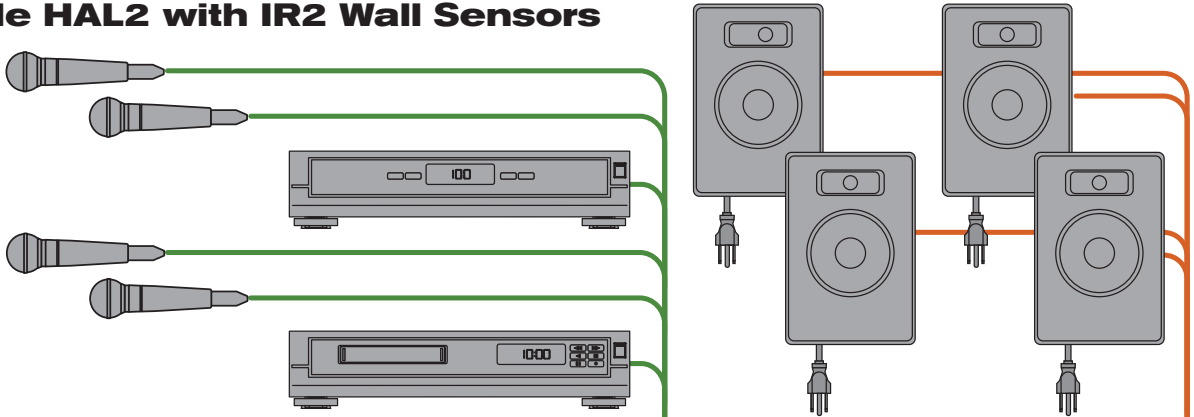

### HAL2 Multiprocessor

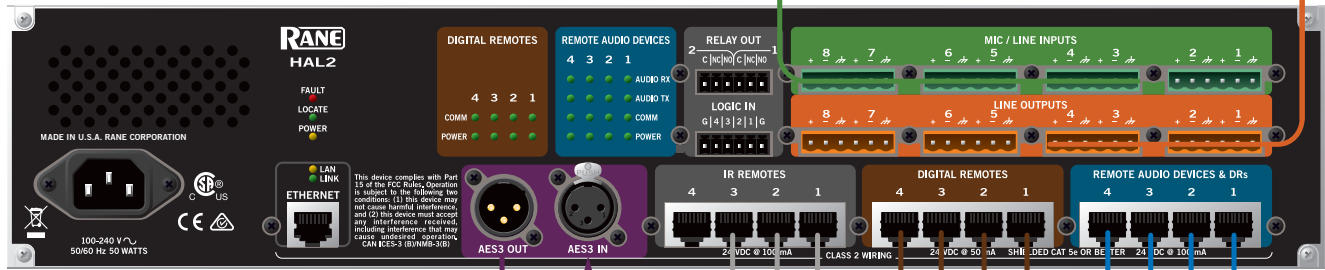

To / From Other HAL2  
or any other AES3-equipped  
device (console, amp input).

### IR2 Wall Sensors

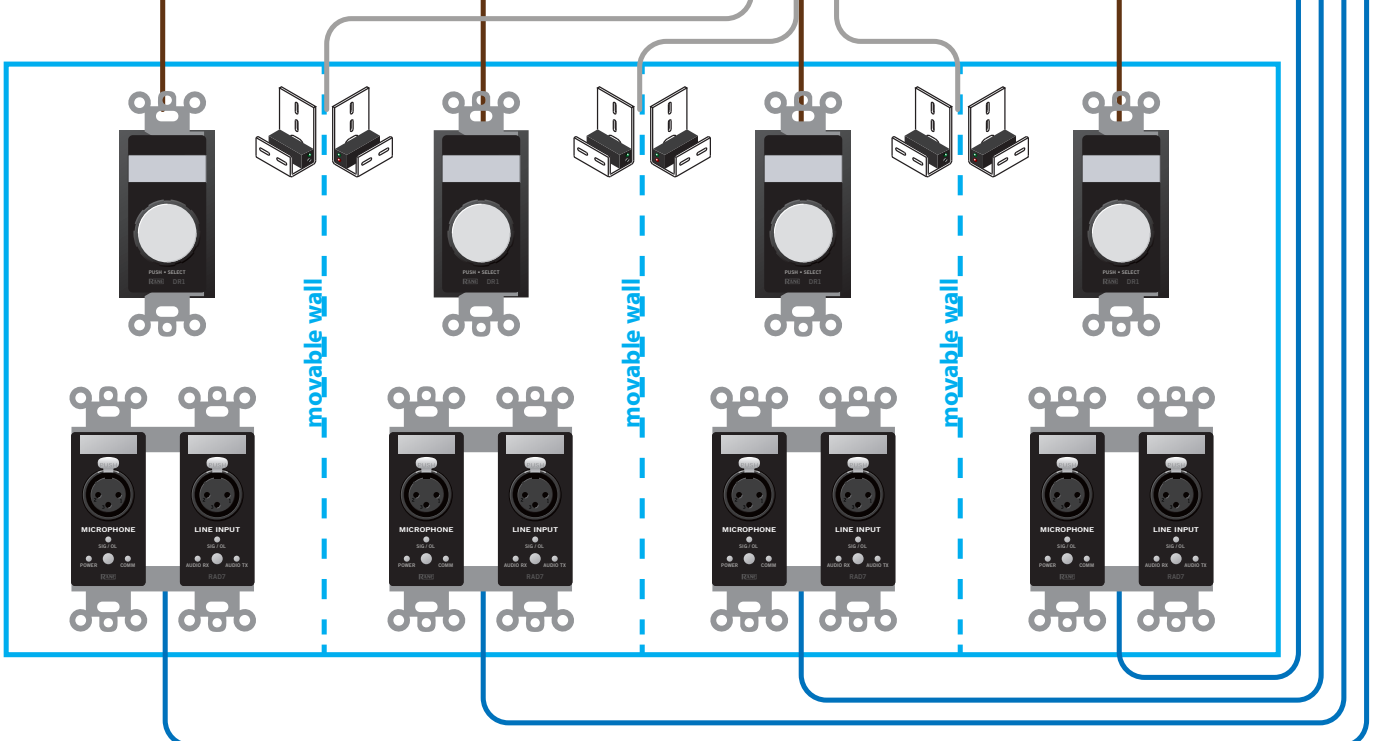

## 8-Zone Restaurant and Bar Background and Live Music with Paging

This system provides background music and paging for eight zones with these requirements:

- The eight zones need manager volume control from the office. These zones include a main dining room, second reserve dining room, arcade, lobby, entryway, kitchen, offices, and the bar.
- A receptionist needs to be able to page into the lobby, dining rooms, lounge, arcade, and entry, using these four scenarios: Page All, Table Ready, Lounge Only and Dining.
- The bar has a stage with good full-range music speakers. XLR inputs on the stage accept input from a musician's or DJ's mixer.
- The bar has televisions which can feed audio to the system during big games or events, which can be selected to be heard in other rooms.
- Background music is available in all areas from a single source. During stage performances, the live music is available to other rooms.
- The main dining, second dining, reception, bar and arcade need to locally switch which music is heard in the overhead speakers, and control volume.

- An accordion wall separates the main dining from the second dining. The wall can open be closed for group dinners, and open for regular business. Private dinners can have a different audio source and volume.

All of the DSP required for paging, distributed background music selection, equalization, dynamics and Level control is included in the HAL2. Though six Digital Remotes are used and the HAL2 only has four DR ports, Digital Remotes can be connected to RAD ports. A single DR3 remote (1) in a manager's office or rack room can provide independent level for all 8 outputs, and an adjustment made at a local DR3 is updated live at the manager's DR3. Selection and volume within 5 different zones is accomplished using 5 DR3 remotes, available in black, ivory or white to match the room decor. The Rane PAGER1 Paging Station (A) at the receptionist supplies paging throughout many zones. A DJ or band can plug a mixer into a RAD3 on the stage wall (B) providing balanced XLR inputs to the built-in system. A DR3 behind the bar sets the room source selection and volume (5).

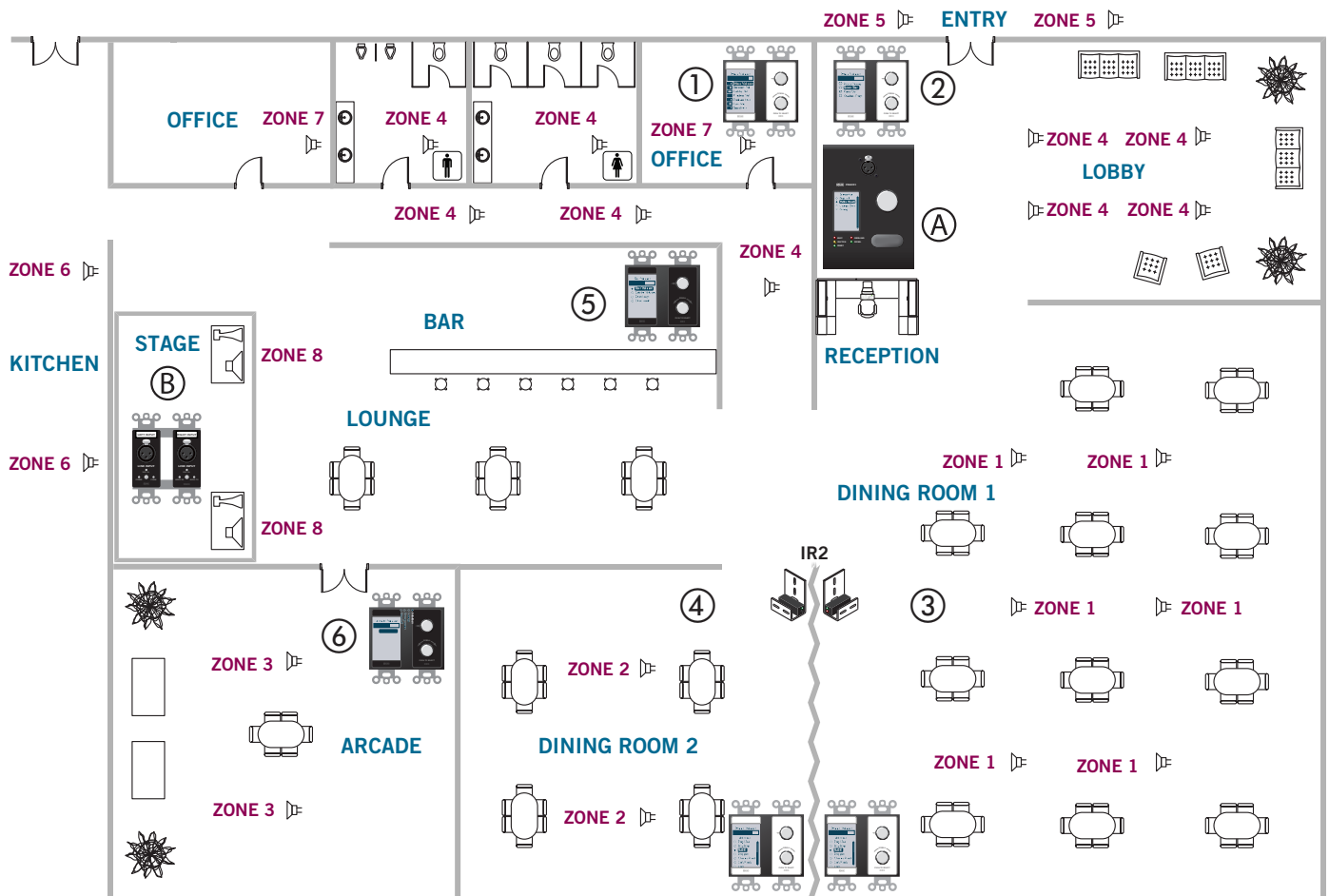

The system has three stereo source inputs:

- Background music service (connects to HAL2 line inputs 1 & 2).
- Television in the bar (connects to HAL2 line inputs 3 & 4).
- Guest musician or DJ input at the stage (connects to the RAD3).

These are all labelled source selections in all the room DR3s.

There are a few unused inputs on the HAL2 for future devices.

These inputs can easily be added through Halogen software to the DR3 remotes installed in each room.

The accordion wall between Dining Room 1 and Dining Room 2 is moveable. The IR2 detector automatically senses when the wall is open or closed, providing separate settings for the DR3s when the wall is closed, and common settings when the wall is open. Room equalization can be automatically switched as well.

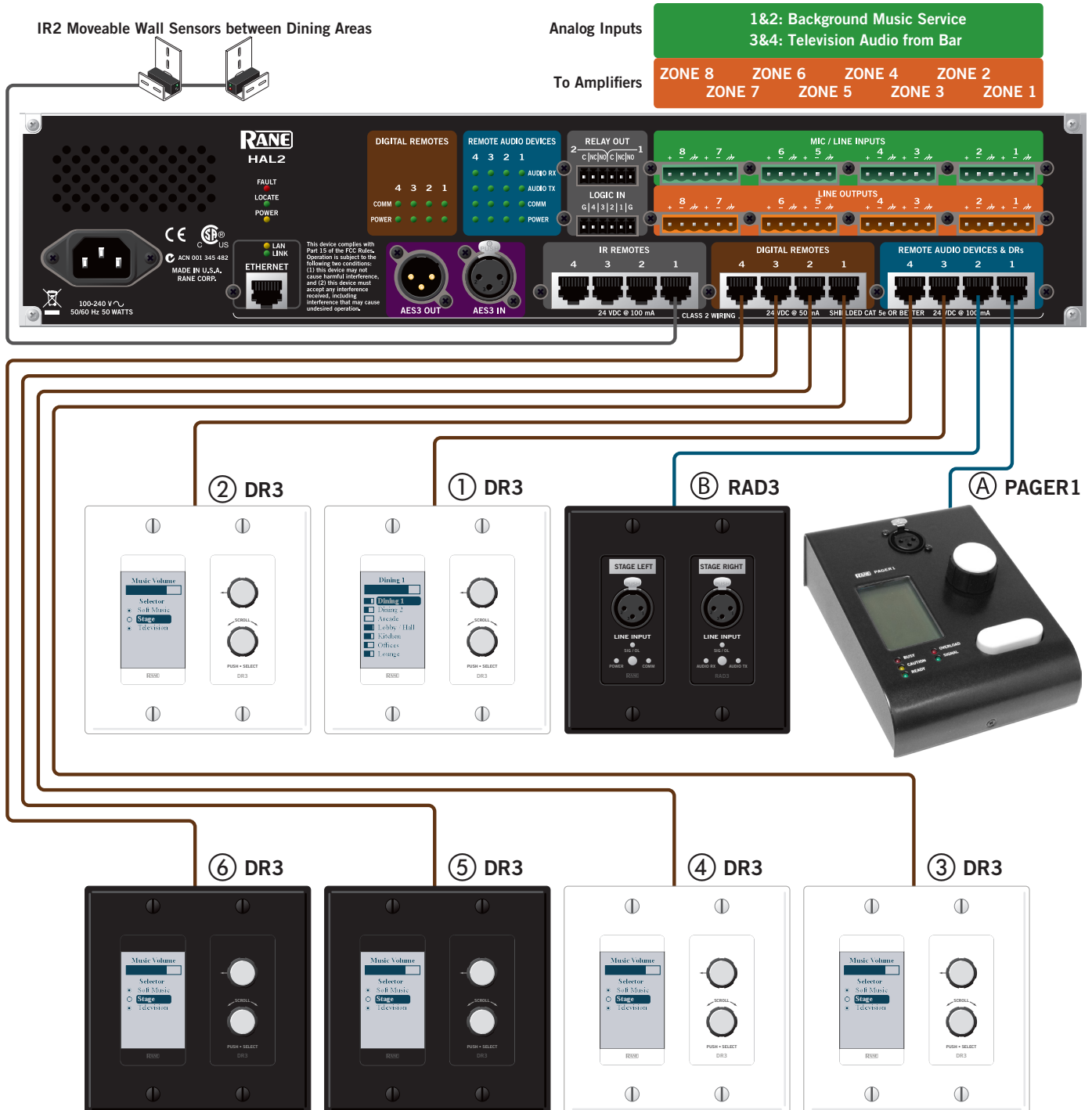

**Halogen 5 Processing Blocks****Dynamics**

Ambient Noise Compensator (ANC)  
 Automatic Gain Control (AGC)  
 Compressor  
 Ducker  
 Expander  
 Gate  
 Limiter

**Misc. blocks**

Level  
 Delay: simple  
 Delay: distance  
 Delay: video  
 Signal Meter  
 Pink Noise: Simple  
 Pink Noise: Ramped  
 Pink Noise: Swept  
 Sine Wave generator  
 Voice Detect

**Filters**

Feedback Suppressor  
 Cut Filter  
 Shelf Filter: single  
 Shelf Filter: multichannel  
 Parametric EQ: single  
 Parametric EQ: multichannel  
 Graphic EQ  
 FIR Filter  
 Crossover: 2-way mono  
 Crossover: 3-way mono  
 Crossover: 4-way mono  
 Crossover: 2-way stereo  
 Crossover: 3-way stereo  
 Crossover: 4-way stereo  
 Crossover: all-pass  
 Crossover: CD horn

**Mixers**

Mixer: 2 to 80 inputs  
 Matrix Mixer  
 Gain-sharing Auto Mixer  
 Gain-sharing Auto Matrix Mixer

**Selectors**

Selector: 2 to 80 inputs  
 Priority Selector  
 Router: 2 to 80 outputs

**Conferencing**

(requires EXP7x)  
 Acoustic Echo Canceling (AEC)  
 Conference Switchboard  
 Conference Room Combine  
 Compressor: Tracking  
 ANC: Tracking

**Paging and Room Combine**

Distributed Program Bus  
 Paging Station with 2-band PEQ, Compressor, Level  
 Paging Zone  
 Emergency Page Zone  
 Zone Processor with Priority Selector, Level, Paging Zone

**HAL2 Multiprocessor Architects & Engineers Specification**

The digital multiprocessor shall be an 18 in x 18 out configuration having eighteen inputs: eight balanced analog on plug-in barrier strips that can be either mic- or line-level with switchable +48 V phantom power, and four digital remote audio device ports providing up to two digital inputs and two digital outputs per port, as well as eight balanced analog line-level outputs on plug-in barrier strips, plus AES3 input and output jacks providing two digital inputs and two digital outputs on XLR. Provisions shall be provided for four digital remotes to control source or preset selection, toggle and/or level control, and control logic expansion, located up to 300 meters (1,000 feet) away. In addition there shall be four contact closure logic inputs on a plug-in barrier strip and two separate relay Form C contact outputs, as well as provisions for four wall-sensing IR remotes. The remote audio devices shall provide A/D and/or D/A conversion based on AES3 transport to the wall up to 150 meters (500 feet) from the multiprocessor, as well as units for cascading automatic microphone mixing up to 64 channels, ambient sensing mics, small amplifiers, and advanced paging stations. All remote audio devices and digital remotes shall connect via shielded CAT 5e (or better) cable to the multiprocessor. Further, all remote audio devices and digital remote devices shall support portable use and hot swapping so that devices may be replaced without shutting down the system, and do so without audio interference, and that all settings for new devices are automatically downloaded from the multiprocessor along with the correct firmware. The unit shall connect to a computer using a standard Ethernet connector. All functions shall be designed, configured and controlled by a software program featuring a graphical user interface that allows managing the global tasks of discovering, connecting to, and applying configurations to the remote digital multiprocessor. The hardware-software combination shall automatically check and display the status, location, CAT 5e crimp and wiring integrity, and that audio is flowing to and/or from all peripheral devices. The hardware multiprocessor and the software shall each include Ethernet ASCII text over TCP/IP control support for third-party control systems such as AMX, Crestron and Stardraw Control, and capable of creating controls for use in a web browser. The processor shall have an internal 100-240 VAC, 50/60 Hz power supply.

*The digital multiprocessor shall be a Rane HAL2 running Rane Halogen software, and using Rane Remote Audio Devices (RADs), Rane Digital Remotes (DRs) and Rane IR2 Wall Sensors.*



**Rhox Áudio e Vídeo Profissional** - SIBS Quadra 2 conjunto C Lote 12  
 Brasília - DF - 71736.203 - Tel (61) 3051-5800  
<https://loja.rhox.com.br>